

# GAMA Venting Tables

---

## VENTING TABLES CATEGORY I CENTRAL FURNACES



COPYRIGHT © 1990  
GAS APPLIANCE MANUFACTURERS ASSOCIATION

7507-183

REVISED: JULY, 1991

## NOTICE

When using Venting Tables Category I Central Furnaces supplement furnished with this Installation Instruction package, use the Terms table below to explain American and Canadian terminology which differs.

## TERMS

AMERICAN TERM	CANADIAN TERM AND DEFINITION
Category I Central Furnaces	In Canada, this type of furnace is a conventionally vented (vertical natural draft) furnace with or without a draft hood.
National Fuel Gas Code-NFPA 54/ANSI Z223.1-1992	National Standard of Canada, CAN/CGA-B149.1 and .2-M91 Natural Gas and Propane Installation Codes with Amendment No. 1

### Section III. General Venting Requirements:

Item 8 of this section applies only to United States instructions. Figures 1 and 2 should not be used as a reference for vent termination in Canada. Use the procedures established by local authorities or in the absence of local authorities, those set by the CAN/CGA-B149 Installation Codes.

# **GAMA VENTING TABLES FOR CATEGORY I CENTRAL FURNACES**

This booklet contains new venting tables designed specifically for use with Category I central furnaces. These tables are unique, in that, industry wide venting tables now exist for fan-assisted combustion system central furnaces. Venting tables for these types of appliances are not contained in the National Fuel Gas Code (NFPA 54/ANSI Z223.1-1988).

All requirements contained in this booklet apply to both Category I draft hood equipped central furnaces as well as fan-assisted combustion system central furnaces. At no time should a venting system for a listed Category II, III, or IV central furnace be sized with these tables. The National Fuel Gas Code (NFPA 54/ANSI Z223.1-1988) may also be used to size venting systems for draft hood equipped central furnaces. However, at this time, the National Fuel Gas Code does not include alternate sizing methods for fan-assisted combustion systems. Therefore, until engineering data is developed to allow alternate sizing methods for Category I fan-assisted central furnaces, the enclosed venting tables must be used for fan-assisted combustion system central furnaces. These tables apply to venting single appliances and common venting multiple appliances in both metal and masonry chimneys.

The new venting tables were developed by Battelle under contract (GRI-5088-245-1728) to the Gas Research Institute (GRI). The computer program (VENT-II) developed by Battelle Columbus generated the venting tables in this booklet and this procedure has been accepted by the American Gas Association Laboratories as an appropriate engineering methodology for determining venting requirements of Category I central furnaces.

For your information, the general venting requirements listed in this booklet are not intended to be used as complete installation instructions and represent only a partial list of venting considerations.

For venting applications that fall outside the parameters of the new venting tables, refer to the furnace manufacturer's complete installation instructions, the specific vent manufacturer's complete installation instructions, and state and local codes.

## **GRI DISCLAIMER**

**LEGAL NOTICE:** This information is, in part, a result of work performed by Battelle under the sponsorship of the Gas Research Institute (GRI). Neither GRI, members of GRI, nor any person acting on behalf of either:

- a. Makes any warranty or representation, express or implied, with respect to the accuracy, completeness, or usefulness of this information, or that the use of any apparatus, method, or process disclosed may not infringe privately owned rights; or
- b. Assumes any liability with respect to the use of, or for damages resulting from the use of, any information, apparatus, method, or process disclosed.

# VENTING REQUIREMENTS FOR CATEGORY I APPLIANCES

## I. INTRODUCTION

This booklet contains the current definitions, instructions, and tables necessary to vent today's modern Category I Gas Fired Appliance. A variety of definitions of new terms describing today's gas appliances are included to supplement the actual venting tables which have been generated to correctly vent various combinations of Category I Appliances using Type B or single-wall metal vent connectors attached to Type B vents or masonry chimneys. Tables are also included covering similar venting material combinations when applied to common venting arrangements of two or more appliances.

Finally, a series of examples are presented demonstrating how the vent tables are used to size the vent connector and the vertical vent for a variety of typical applications.

## II. DEFINITION OF TERMS

**"Fan Assisted Combustion System"** An appliance equipped with an integral mechanical means to either draw or force products of combustion through the combustion chamber and/or heat exchanger.

**"FAN Min"** refers to the minimum appliance input rating of a Category I appliance with a fan-assisted combustion system that could be attached to the vent.

**"FAN Max"** refers to the maximum appliance input rating of a Category I appliance with a fan-assisted combustion system that could be attached to the vent.

**"NAT Max"** refers to the maximum appliance input rating of a Category I appliance equipped with a draft hood that could be attached to the vent. There are no minimum appliance input ratings for draft hood-equipped appliances.

**"FAN+FAN"** refers to the maximum combined input rating of two or more fan-assisted appliances attached to the common vent.

**"FAN+NAT"** refers to the maximum combined input rating of one or more fan-assisted appliance and one or more draft hood-equipped appliance attached to the common vent.

**"NAT+NAT"** refers to the maximum combined input rating of two or more draft hood-equipped appliances attached to the common vent.

**"NR"** means not recommended due to potential for condensate formation and/or pressurization of the venting system.

**"NA"** means not applicable due to physical or geometric constraints.

**DraftHood** A device built into an appliance, or made a part of the vent connector from an appliance, which is designed to (1) provide for the ready escape of the flue gases from the appliance in the event of no draft, backdraft, or stoppage beyond the draft hood, (2) prevent a backdraft from entering the appliance, and (3) neutralize the effect of stack action of the chimney or gas vent upon the operation of the appliance.

**Vent** A passageway used to convey flue gases from gas utilization equipment, or their vent connectors, to the outside atmosphere.

**Vent Connector** The pipe or duct which connects a fuel-gas burning appliance to a vent or chimney.

**Flue Collar** That portion of an appliance designed for the attachment of a draft hood, vent connector, or venting system.

**Categorized Vent Diameter** The minimum vent diameter permissible for Category I appliances to maintain a nonpositive vent static pressure when tested in accordance with nationally recognized standards.

### III. GENERAL VENTING REQUIREMENTS

All requirements contained in this document apply to both Category I draft hood equipped and fan-assisted combustion appliances. At no time should a venting system for a listed Category II, III, or IV appliance be sized with these Tables. The alternate sizing methods described in the National Fuel Gas Code (NFPA54/ANSI Z223.1-1988) may also be used to size the venting system for a draft hood equipped appliance. At this time, alternate sizing methods have not been developed for fan-assisted appliances. Therefore, until engineering data is developed to allow alternate sizing methods for Category I fan-assisted appliances, the vent tables must be used.

- 1) The venting tables included in this instruction apply to vents and chimneys internal to the structure below the roof line. Exterior chimneys or vents not enclosed by the structure or a chase below the roof line may experience continuous condensation depending on locality. Consult local gas utility, appliance manufacturer and/or local codes. A chimney with one or more sides exposed to the outside of the structure is considered to be an exterior chimney. A Type B or listed chimney lining system passing through an unused masonry chimney flue is not considered to be exposed to the outdoors.
- 2) If the vent or connector size determined from the tables is smaller than the appliance draft hood outlet or flue collar, the smaller size may be used provided:
  - a) The total vent height "H" is at least 10 FT.
  - b) Vents or connectors for appliance draft hood outlets or flue collars 12 inches in diameter or smaller are not reduced more than one table size (e.g. 12 inches to 10 inches is a one size reduction).
  - c) Vents or connectors for appliance draft hood or flue collars above 12 inches in diameter are not reduced more than two table sizes (e.g. 24 inches to 20 inches is a two size reduction).
  - d) The maximum capacity listed in the tables for a fan-assisted appliance is reduced by 10% (0.90 x maximum capacity).
  - e) The draft hood outlet is greater than 4 inches in diameter. Do not connect a 3 inch diameter vent or connector to a 4 inch diameter draft hood outlet. This provision does not apply to fan-assisted appliances.

- 3) Single appliance venting configurations with zero lateral lengths, Tables 1 & 2, are assumed to have no elbows in the vent system. For all other vent configurations, the vent system is assumed to have two 90° elbows. For each additional 90° elbow, or equivalent\* beyond two, the maximum capacity listed in the venting table should be reduced by 10 percent (0.90 x maximum listed capacity).

\* Two 45° elbows are equivalent to one 90° elbow.

- 4) The common venting Tables 3, 4, 7, & 8 were generated using a maximum horizontal vent connector length of 1 1/2 feet (18 inches) for each inch of connector diameter as follows:

CONNECTOR DIAMETER (INCHES)	MAXIMUM HORIZONTAL CONNECTOR LENGTH (FEET)
3	4 1/2
4	6
5	7 1/2
6	9
7	10 1/2
8	12
9	13 1/2
10	15
12	18
14	21
16	24
18	27
20	30
22	33
24	36

The vent connector should be routed to the vent utilizing the shortest possible route. Connectors with longer horizontal lengths than those listed above are possible under the following conditions:

- a) The maximum capacity (Fan Max. or Nat Max.) of the vent connector shall be reduced 10% for each additional multiple of the length listed above. For example, the maximum length listed above for a 4 inch connector is 6 feet. With a connector length greater than 6 feet but not exceeding 12 feet, the maximum capacity must be reduced by 10% (0.90 x maximum vent connector capacity). With a connector length greater than 12 feet but not exceeding 18 feet, the maximum capacity must be reduced by 20% (0.80 x maximum vent capacity).

b) The minimum capacity (Fan Min.) shall be determined by referring to the corresponding single appliance table (Tables 1 and 2). In this case, for each appliance the entire vent connector and common vent from the appliance to the vent termination would be treated as a single appliance vent, as if the other appliances were not present.

- 5) If vent connectors are combined prior to entering the common vent, the maximum common vent capacity listed in the common venting tables must be reduced by 10%, the equivalent of 1 (one) 90° elbow (0.90 x maximum common vent capacity). See Figure 7. The horizontal length of the common vent connector manifold (L) should not exceed 1-1/2 feet (18 inches) for each inch of common vent connector manifold diameter.
- 6) If the common vertical vent is offset as shown in Figure 8, the maximum common vent capacity listed in the common venting tables should be reduced by 20%, the equivalent of 2 (two) 90° elbows (0.80 x maximum common vent capacity). The horizontal length of the offset shall not exceed 1 1/2 feet for each inch of common vent diameter.
- 7) The common vent diameter must always be at least as large as the largest vent connector diameter. All interconnection fittings must also be the same size as the common vent.
- 8) Type B gas vents shall terminate above the roof surface with a listed cap or a listed roof assembly in accordance with the terms of their respective listings and the vent manufacturer's instructions.

**VENT CAPS 12" AND SMALLER**

Listed gas venting systems using listed vent caps 12" and smaller in size may terminate in accordance with the VENT TERMINATION TABLE. (SEE FIGURE 1)

**VENT CAPS LARGER THAN 12"**

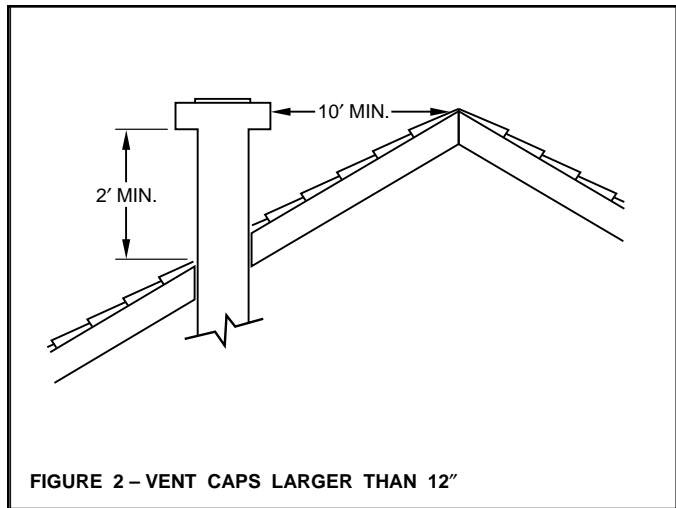
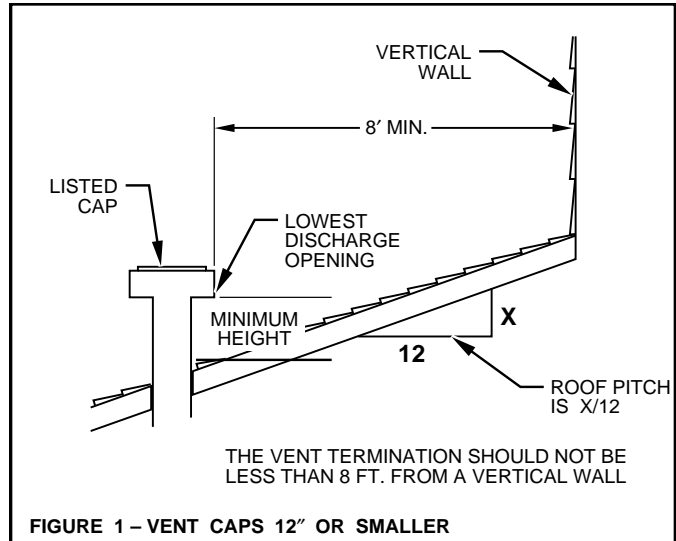
Listed vent caps larger than 12" must be located at least 2 feet above the highest point and at least 2 feet higher than any portion of a building within a horizontal distance of 10 Feet. (SEE FIGURE 2)

- 9) Use sea level input rating when determining maximum capacity for high altitude installation. Use actual input rating for determining minimum capacity for high altitude installation.

**GAS VENT TERMINATION TABLE**

ROOF PITCH	MINIMUM HEIGHT
FLAT TO 7/12	1.0 FEET*
OVER 7/12 TO 8/12	1.5 FEET
OVER 8/12 TO 9/12	2.0 FEET
OVER 9/12 TO 10/12	2.5 FEET
OVER 10/12 TO 11/12	3.25 FEET
OVER 11/12 TO 12/12	4.0 FEET
OVER 12/12 TO 14/12	5.0 FEET
OVER 14/12 TO 16/12	6.0 FEET
OVER 16/12 TO 18/12	7.0 FEET
OVER 18/12 TO 20/12	7.5 FEET
OVER 20/12 TO 21/12	8.0 FEET

\*THIS REQUIREMENT COVERS MOST INSTALLATIONS



- 10) No portion of the venting system can extend into, or pass through any circulating air duct or plenum.
- 11) All vent pipe passing through floors, walls, and ceilings must be installed with the listed clearance to combustible materials and be fire stopped according to local codes. In the absence of local codes, refer to NFGC (Z223.1)
- 12) Vent connectors serving Category I appliances shall not be connected to any portion of mechanical draft systems operating under positive pressure such as Category III or IV Venting Systems.
- 13) A Category I appliance must never be connected to a chimney that is servicing a solid fuel appliance. If a fireplace chimney flue is used to vent this appliance, the fireplace opening must be permanently sealed.
- 14) A vent connector shall be supported without any dips or sags and shall slope a minimum of 1/4 inch per lineal foot of connector, back towards the appliance.
- 15) Vent connectors shall be firmly attached to draft hood outlets or flue collars by sheet-metal screws or other approved means, except vent connectors of listed Type B vent material which shall be assembled in accordance with the manufacturer's instructions. Joints between sections of single wall connector piping shall be fastened by sheet-metal screws or other approved means.
- 16) When the vent connector used for Category I appliances must be located in or pass through a crawl space or other area which may be cold, that portion of the vent connector shall be of listed double-wall Type B vent material or material having equivalent insulation qualities.
- 17) The entire length of single wall metal vent connector shall be readily accessible for inspection, cleaning, and replacement.
- 18) For appliances with more than one input rate, the minimum vent or connector (Fan Min) capacity determined from the tables shall be less than the lowest appliance input rating and the maximum vent or connector (Fan or Nat Max.) capacity determined from the tables shall be greater than the highest appliance input rating.

19) For single appliance vents:

- a) If the vertical vent or tile lined chimney has a larger diameter or flow area than the vent connector, use the vertical vent diameter to determine the minimum vent capacity and the vent connector diameter to determine the maximum vent capacity. The flow area of the vertical vent, however, shall not exceed 7 times the flow area of the listed appliance categorized vent area, draft hood outlet area or flue collar area unless designed in accordance with approved engineering methods. See Table 9 for calculated areas.

b) For multiple appliance vents:

The flow area of the largest section of vertical vent or chimney shall not exceed 7 times the smallest listed appliance categorized vent area, flue collar area, or draft hood outlet area unless designed in accordance with approved engineering methods. See Table for calculated areas.

$$\text{Maximum vent or tile lined chimney flow area} = \frac{TT (D^*)^2}{4} \times 7$$

\* Draft hood outlet diameter, flue collar diameter, or listed appliance categorized vent diameter.

- c) In no case, shall the vent connector be upsized more than 2 consecutive table size diameters over the size of the draft hood outlet, flue collar outlet, or listed appliance categorized vent. Example: An appliance with a 4 inch diameter flue outlet collar or draft hood outlet cannot be vented with a connector diameter larger than 6 inches.

20) Masonry chimneys used to vent Category I central furnaces must be either tile-lined or lined with a listed metal lining system or dedicated gas vent. Unlined masonry chimneys are prohibited. (See Note 1).

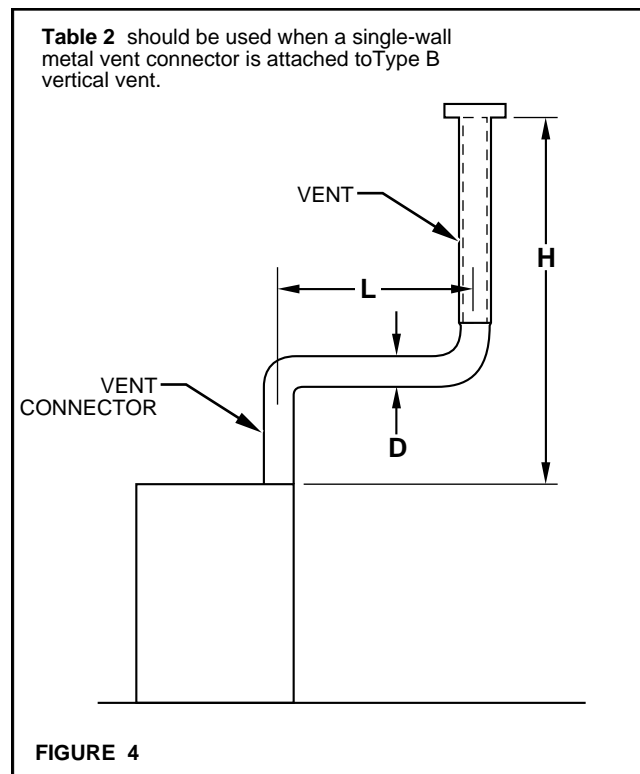
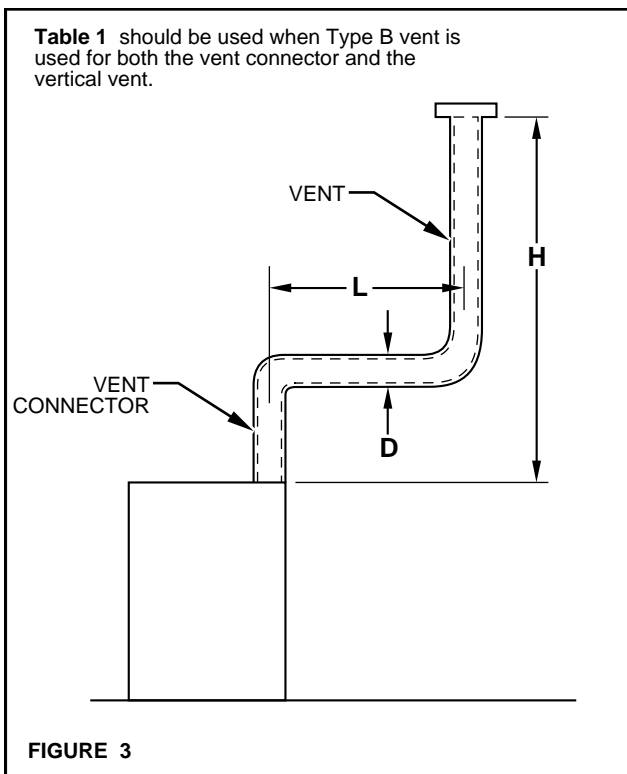
21) A fan assisted furnace may be common vented into an existing masonry chimney provided:

- a. The chimney is currently serving at least one draft hood equipped appliance.
- b. The vent connectors and chimney are sized in accordance with Tables 7 & 8.

**SINGLE APPLIANCE VENTING OF A FAN ASSISTED FURNACE INTO A TILE LINED, MASONRY CHIMNEY IS PROHIBITED. THE CHIMNEY MUST FIRST BE LINED WITH EITHER TYPE B VENT SIZED IN ACCORDANCE WITH TABLES 1 OR 2 OR A LISTED SINGLE WALL, METAL LINING SYSTEM, SIZED IN ACCORDANCE WITH NOTE 22.**

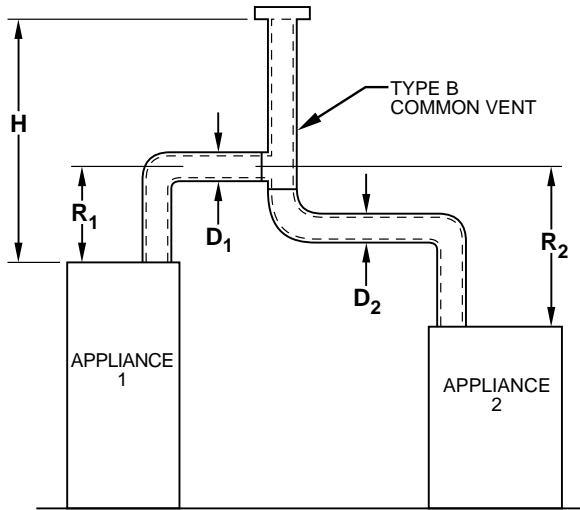
- 22) Listed, corrugated metallic chimney liner systems in masonry chimneys shall be sized by using Tables 1 or 2 for dedicated venting and Tables 3 or 4 for common venting with the maximum capacity reduced by 20% (0.80 x maximum capacity) and the minimum capacity as shown in the applicable table. Corrugated metal vent systems installed with bends or offsets require additional reduction of the vent maximum capacity (See Note 6).
- 23) For multiple units of gas utilization equipment all located on one floor, available total height "H" is measured from the highest drafthood outlet or flue collar up to the level of the cap or terminal. Connector rise "R" is measured from the drafthood outlet or flue collar to the level where the vent gas streams come together. (Not applicable to multi-story).
- 24) For multi-story installations, available total height for each segment of the system "H" is the vertical distance between the highest drafthood outlet or flue collar entering that segment and the centerline of the next higher interconnection tee (See Figure 13).
- 25) The size of the lowest connector and of the vertical vent leading to the lowest interconnection of a multi-story system must be in accordance with Table 1 OR 2, for available total height "H" up to the lowest interconnection (See Figure 14).
- 26) Common vents in multi-story systems shall be type B when used in multi-story systems and have no offsets.
- 27) Numbers followed by an asterisk (\*) in Table 6, indicate the possibility of continuous condensation, depending on locality. Consult appliance manufacturer, local serving gas supplier, and/or authority having jurisdiction.
- 28) In a single run of vent or vent connector, more than one diameter and type of pipe are permitted to be used, provided that all the sizes are permitted by the tables.
- 29) If the desired vent height and connector rise and/or lateral are between the table entries, linear interpolation is permitted for calculation of the permissible appliance input ratings. Extrapolation beyond the table entries is not recommended. (See Example 7)
- 30) All combinations of pipe sizes, single-wall, and double-wall metal pipe are allowed within any connector run(s) or within the common vent provided ALL of the appropriate tables permit ALL of the desired sizes and types of pipe, as if they were used for the entire length of the subject connector or vent. If single-wall and Type B double-wall metal pipe are used for vent connectors, the common vent must be sized using Table 4.
- 31) Locate draft hood outlet or flue collar of smallest input appliance closest to or under common vent.
- 32) When vent table permits more than one diameter of pipe to be used for a connector or vent, the smallest permitted diameter should be preferred.

### TYPICAL VENTING APPLICATIONS



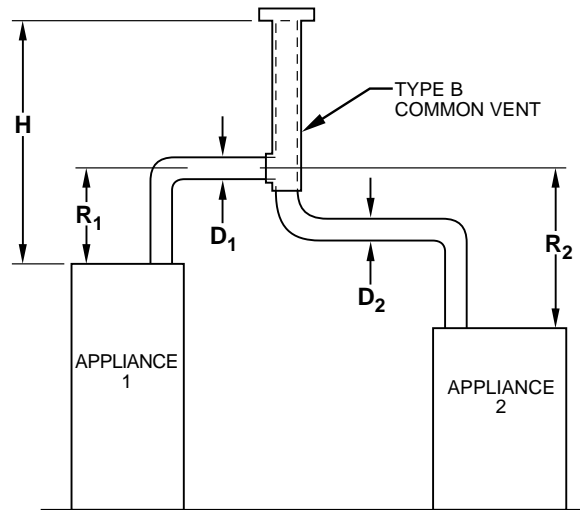


**Table 3** should be used when Type B vent connectors are attached to a Type B common vent.



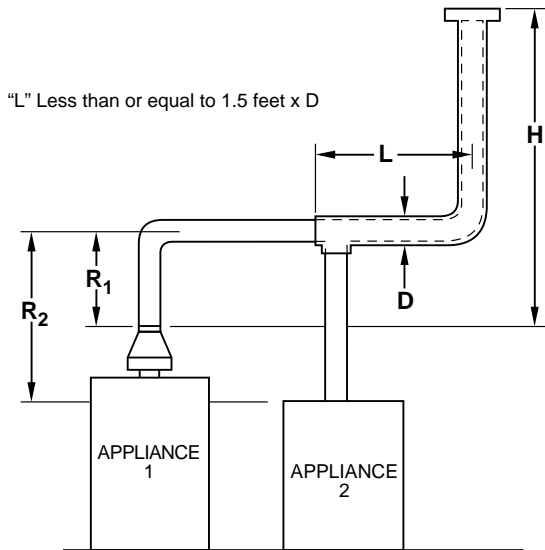
**FIGURE 5**

**Table 4** should be used when single-wall metal vent connectors are attached to a Type B common vent.



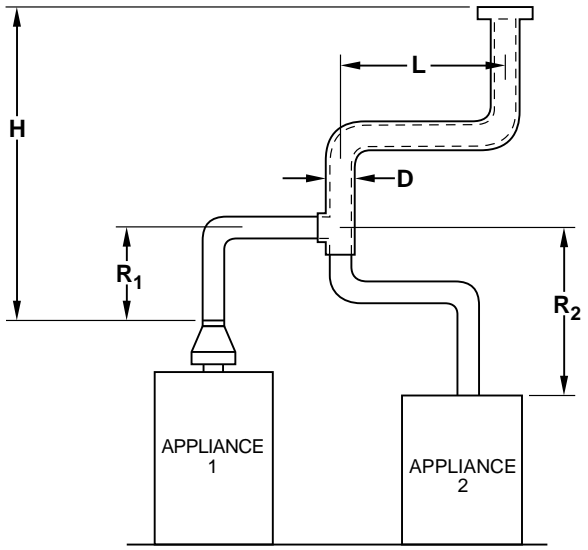
**FIGURE 6**

Schematic Diagram showing a typical manifolded common vent section "L" of the vent connector. (See Note 5)



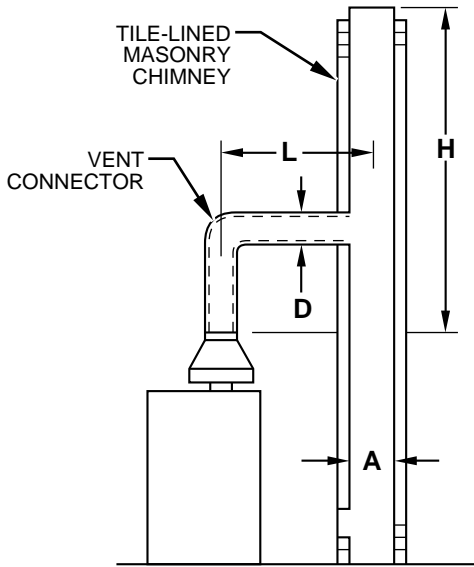
**FIGURE 7**

Schematic Diagram showing offset in the common vent section of the vertical vent. (See Note 6)



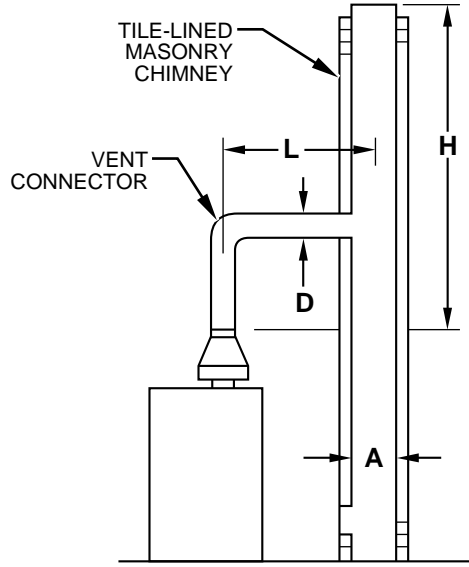
**FIGURE 8**

**Table 5** shall be used when a Type B, double-wall vent connector is attached to a tile lined masonry chimney.



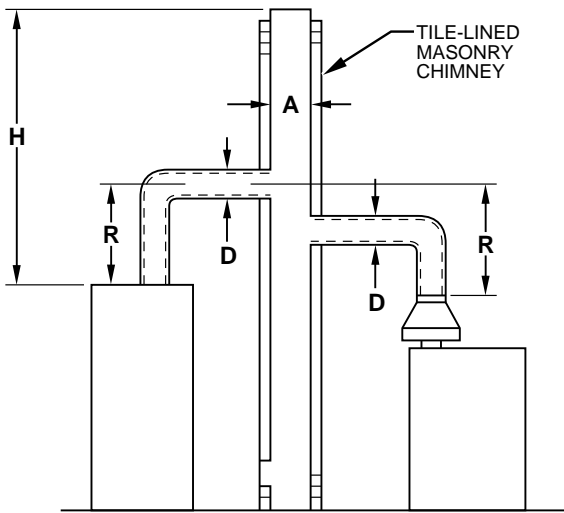
**FIGURE 9**

**Table 6** shall be used when a single-wall metal vent connector is attached to a tile lined masonry chimney.



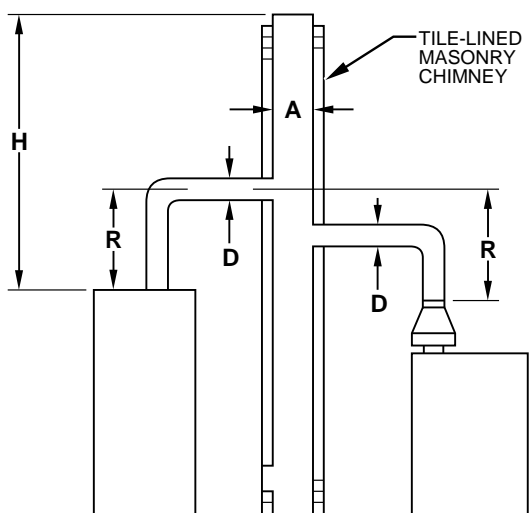
**FIGURE 10**

**Table 7** shall be used when Type B double-wall vent connectors are attached to a tile lined masonry chimney.



**FIGURE 11**

**Table 8** shall be used when single-wall metal vent connectors are attached to a tile lined masonry chimney.



**FIGURE 12**

## VENT TABLES

Capacity of Type B Double-Wall Vents with Type B Double-Wall Connectors  
Serving a Single Category I Appliance

**TABLE 1**

Height H (ft)		Lateral L (ft)		Vent and Connector Diameter - D (inches)																							
				3"		4"			5"			6"			7"			8"			9"						
				Appliance Input Rating in Thousands of Btu Per Hour																							
		FAN		NAT	FAN		NAT	FAN		NAT	FAN		NAT	FAN		NAT	FAN		NAT	FAN		NAT					
		Min	Max	Max	Min	Max	Max	Min	Max	Max	Min	Max	Max	Min	Max	Max	Min	Max	Max	Min	Max	Max					
6	0	0	78	46	0	152	86	0	251	141	0	375	205	0	524	285	0	698	370	0	897	470					
	2	13	51	36	18	97	67	27	157	105	32	232	157	44	321	217	53	425	285	63	543	370					
	4	21	49	34	30	94	64	39	153	103	50	227	153	66	316	211	79	419	279	93	536	362					
	6	25	46	32	36	91	61	47	149	100	59	223	149	78	310	205	93	413	273	110	530	354					
8	0	0	84	50	0	165	94	0	276	155	0	415	235	0	583	320	0	780	415	0	1006	537					
	2	12	57	40	16	109	75	25	178	120	28	263	180	42	365	247	50	483	322	60	619	418					
	5	23	53	38	32	103	71	42	171	115	53	255	173	70	356	237	83	473	313	99	607	407					
	8	28	49	35	39	98	66	51	164	109	64	247	165	84	347	227	99	463	303	117	596	396					
10	0	0	88	53	0	175	100	0	295	166	0	447	255	0	631	345	0	847	450	0	1096	585					
	2	12	61	42	17	118	81	23	194	129	26	289	195	40	402	273	48	533	355	57	684	457					
	5	23	57	40	32	113	77	41	187	124	52	280	188	68	392	263	81	522	346	95	671	446					
	10	30	51	36	41	104	70	54	176	115	67	267	175	88	376	245	104	504	330	122	651	427					
15	0	0	94	58	0	191	112	0	327	187	0	502	285	0	716	390	0	970	525	0	1263	682					
	2	11	69	48	15	136	93	20	226	150	22	339	225	38	475	316	45	633	414	53	815	544					
	5	22	65	45	30	130	87	39	219	142	49	330	217	64	463	300	76	620	403	90	800	529					
	10	29	59	41	40	121	82	51	206	135	64	315	208	84	445	288	99	600	386	116	777	507					
	15	35	53	37	48	112	76	61	195	128	76	301	198	98	429	275	115	580	373	134	755	491					
20	0	0	97	61	0	202	119	0	349	202	0	540	307	0	776	430	0	1057	575	0	1384	752					
	2	10	75	51	14	149	100	18	250	166	20	377	249	33	531	346	41	711	470	50	917	612					
	5	21	71	48	29	143	96	38	242	160	47	367	241	62	519	337	73	697	460	86	902	599					
	10	28	64	44	38	133	89	50	229	150	62	351	228	81	499	321	95	675	443	112	877	576					
	15	34	58	40	46	124	84	59	217	142	73	337	217	94	481	308	111	654	427	129	853	557					
20	48	52	35	55	116	78	69	206	134	84	322	206	107	464	295	125	634	410	145	830	537						
30	0	0	100	64	0	213	128	0	374	220	0	587	336	0	853	475	0	1173	650	0	1548	855					
	2	9	81	56	13	166	112	14	283	185	18	432	280	27	613	394	33	826	535	42	1072	700					
	5	21	77	54	28	160	108	36	275	176	45	421	273	58	600	385	69	811	524	82	1055	688					
	10	27	70	50	37	150	102	48	262	171	59	405	261	77	580	371	91	788	507	107	1028	668					
	15	33	64	NR	44	141	96	57	249	163	70	389	249	90	560	357	105	765	490	124	1002	648					
	20	56	58	NR	53	132	90	66	237	154	80	374	237	102	542	343	119	743	473	139	977	628					
	30	NR	NR	NR	73	113	NR	88	214	NR	104	346	219	131	507	321	149	702	444	171	929	594					
50	0	0	101	67	0	216	134	0	397	232	0	633	363	0	932	518	0	1297	708	0	1730	952					
	2	8	86	61	11	183	122	14	320	206	15	497	314	22	715	445	26	975	615	33	1276	813					
	5	20	82	NR	27	177	119	35	312	200	43	487	308	55	702	438	65	960	605	77	1259	798					
	10	26	76	NR	35	168	114	45	299	190	56	471	298	73	681	426	86	935	589	101	1230	773					
	15	59	70	NR	42	158	NR	54	287	180	66	455	288	85	662	413	100	911	572	117	1203	747					
	20	NR	NR	NR	50	149	NR	63	275	169	76	440	278	97	642	401	113	888	556	131	1176	722					
	30	NR	NR	NR	69	131	NR	84	250	NR	99	410	259	123	605	376	141	844	522	161	1125	670					
100	0	NR	NR	NR	0	218	NR	0	407	NR	0	665	400	0	997	560	0	1411	770	0	1908	1040					
	2	NR	NR	NR	10	194	NR	12	354	NR	13	566	375	18	831	510	21	1155	700	25	1536	935					
	5	NR	NR	NR	26	189	NR	33	347	NR	40	557	369	52	820	504	60	1141	692	71	1519	926					
	10	NR	NR	NR	33	182	NR	43	335	NR	53	542	361	68	801	493	80	1118	679	94	1492	910					
	15	NR	NR	NR	40	174	NR	50	321	NR	62	528	353	80	782	482	93	1095	666	109	1465	895					
	20	NR	NR	NR	47	166	NR	59	311	NR	71	513	344	90	763	471	105	1073	653	122	1438	880					
	30	NR	NR	NR	NR	NR	NR	78	290	NR	92	483	NR	115	726	449	131	1029	627	149	1387	849					
50	NR	NR	NR	NR	NR	NR	NR	NR	NR	147	428	NR	180	651	405	197	944	575	217	1288	787						





## VENT TABLES

### Capacity of Type B Double-Wall Vents with Type B Double-Wall Connectors Serving Two or more Category I Appliances

**TABLE 3**

**Vent Connector Capacity**

Vent Height H (ft)	Connector Rise R (ft)	Vent Connector Diameter - D (inches)																							
		3"		4"			5"			6"			7"			8"			9"			10"			
		Appliance Input Rating Limits in Thousands of Btu Per Hour																							
		FAN		NAT	FAN		NAT	FAN		NAT	FAN		NAT	FAN		NAT	FAN		NAT	FAN		NAT	FAN		NAT
Min	Max	Max	Min	Max	Max	Min	Max	Max	Min	Max	Max	Min	Max	Max	Min	Max	Max	Min	Max	Max	Min	Max	Max		
6	1	22	37	26	35	66	46	46	106	72	58	164	104	77	225	142	92	296	185	109	376	237	128	466	289
	2	23	41	31	37	75	55	48	121	86	60	183	124	79	253	168	95	333	220	112	424	282	131	526	345
	3	24	44	35	38	81	62	49	132	96	62	199	139	82	275	189	97	363	248	114	463	317	134	575	386
8	1	22	40	27	35	72	48	49	114	76	64	176	109	84	243	148	100	320	194	118	408	248	138	507	303
	2	23	44	32	36	80	57	51	128	90	66	195	129	86	269	175	103	356	230	121	454	294	141	564	358
	3	24	47	36	37	87	64	53	139	101	67	210	145	88	290	198	105	384	258	123	492	330	143	612	402
10	1	22	43	28	34	78	50	49	123	78	65	189	113	89	257	154	106	341	200	125	436	257	146	542	314
	2	23	47	33	36	86	59	51	136	93	67	206	134	91	282	182	109	374	238	128	479	305	149	596	372
	3	24	50	37	37	92	67	52	146	104	69	220	150	94	303	205	111	402	268	131	515	342	152	642	417
15	1	21	50	30	33	89	53	47	142	83	64	220	120	88	298	163	110	389	214	134	493	273	162	609	333
	2	22	53	35	35	96	63	49	153	99	66	235	142	91	320	193	112	419	253	137	532	323	165	658	394
	3	24	55	40	36	102	71	51	163	111	68	248	160	93	339	218	115	445	286	140	565	365	167	700	444
20	1	21	54	31	33	99	56	46	157	87	62	246	125	86	334	171	107	436	224	131	552	285	158	681	347
	2	22	57	37	34	105	66	48	167	104	64	259	149	89	354	202	110	463	265	134	587	339	161	725	414
	3	23	60	42	35	110	74	50	176	116	66	271	168	91	371	228	113	486	300	137	618	365	164	764	466
30	1	20	62	33	31	113	59	45	181	93	60	288	134	83	391	182	103	512	238	125	649	305	151	802	372
	2	21	64	39	33	118	70	47	190	110	62	299	158	85	408	215	105	535	282	129	679	360	155	840	439
	3	22	66	44	34	123	79	48	198	124	64	309	178	88	423	242	108	555	317	132	706	405	158	874	494
50	1	19	71	36	30	133	64	43	216	101	57	349	145	78	477	197	97	627	257	120	797	330	144	984	403
	2	21	73	43	32	137	76	45	223	119	59	358	172	81	490	234	100	645	306	123	820	392	148	1014	478
	3	22	75	48	33	141	86	46	229	134	61	366	194	83	502	263	103	661	343	126	842	441	151	1043	538
100	1	18	82	37	28	158	66	40	262	104	53	442	150	73	611	204	91	810	266	112	1038	341	135	1285	417
	2	19	83	44	30	161	79	42	267	123	55	447	178	75	619	242	94	822	316	115	1054	405	139	1306	494
	3	20	84	50	31	163	89	44	272	138	57	452	200	78	627	272	97	834	355	118	1069	455	142	1327	555

**Common Vent Capacity**

Vent Height H (ft)	Common Vent Diameter - D (inches)																				
	4"			5"			6"			7"			8"			9"			10"		
	Combined Appliance Input Rating in Thousands of Btu Per Hour																				
	FAN	FAN	NAT	FAN	FAN	NAT	FAN	FAN	NAT	FAN	FAN	NAT	FAN	FAN	NAT	FAN	FAN	NAT	FAN	FAN	NAT
+FAN	+NAT	+NAT	+FAN	+NAT	+NAT	+FAN	+NAT	+NAT	+FAN	+NAT	+NAT	+FAN	+NAT	+NAT	+FAN	+NAT	+NAT	+FAN	+NAT	+NAT	
6	92	81	65	140	116	103	204	161	147	309	248	200	404	314	260	547	434	335	672	520	410
8	101	90	73	155	129	114	224	178	163	339	275	223	444	348	290	602	480	378	740	577	465
10	110	97	79	169	141	124	243	194	178	367	299	242	477	377	315	649	522	405	800	627	495
15	125	112	91	195	164	144	283	228	206	427	352	280	556	444	365	753	612	465	924	733	565
20	136	123	102	215	183	160	314	255	229	475	394	310	621	499	405	842	688	523	1035	826	640
30	152	138	118	244	210	185	361	297	266	547	459	360	720	585	470	979	808	605	1209	975	740
50	167	153	134	279	244	214	421	353	310	641	547	423	854	706	550	1164	977	705	1451	1188	860
100	175	163	NR	311	277	NR	489	421	NR	751	658	479	1025	873	625	1408	1215	800	1784	1502	975

## VENT TABLES

### Capacity of Type B Double-Wall Vents with Type B Double-Wall Connectors Serving two or more Category I Appliances

**TABLE 3 (cont'd)**

**Vent Connector Capacity**

Vent Connector Height H (ft)		Rise R (ft)		Vent Connector Diameter - D (inches)																					
				12"		14"			16"			18"			20"			22"			24"				
				Appliance Input Rating Limits in Thousands of Btu Per Hour																					
				FAN			NAT			FAN			NAT			FAN			NAT			FAN			NAT
		Min	Max	Max	Min	Max	Max	Min	Max	Max	Min	Max	Max	Min	Max	Max	Min	Max	Max	Min	Max	Max	Min	Max	Max
6	2	174	764	496	223	1046	653	281	1371	853	346	1772	1080	NA	NA	NA	NA	NA	NA	NA	NA	NA	NA	NA	NA
	4	180	897	616	230	1231	827	287	1617	1081	352	2069	1370	NA	NA	NA	NA	NA	NA	NA	NA	NA	NA	NA	NA
	6	NA	NA	NA	NA	NA	NA	NA	NA	NA	NA	NA	NA	NA	NA	NA	NA	NA	NA	NA	NA	NA	NA	NA	NA
8	2	186	822	516	238	1126	696	298	1478	910	365	1920	1150	NA	NA	NA	NA	NA	NA	NA	NA	NA	NA	NA	NA
	4	192	952	644	244	1307	884	305	1719	1150	372	2211	1460	471	2737	1800	560	3319	2180	662	3957	2590			
	6	198	1050	772	252	1445	1072	313	1902	1390	380	2434	1770	478	3018	2180	568	3665	2640	669	4373	3130			
10	2	196	870	536	249	1195	730	311	1570	955	379	2049	1205	NA	NA	NA	NA	NA	NA	NA	NA	NA	NA	NA	NA
	4	201	997	664	256	1371	924	318	1804	1205	387	2332	1535	486	2887	1890	581	3502	2280	686	4175	2710			
	6	207	1095	792	263	1509	1118	325	1989	1455	395	2556	1865	494	3169	2290	589	3849	2760	694	4593	3270			
15	2	214	967	568	272	1334	790	336	1760	1030	408	2317	1305	NA	NA	NA	NA	NA	NA	NA	NA	NA	NA	NA	NA
	4	221	1085	712	279	1499	1006	344	1978	1320	416	2579	1665	523	3197	2060	624	3881	2490	734	4631	2960			
	6	228	1181	856	286	1632	1222	351	2157	1610	424	2796	2025	533	3470	2510	634	4216	3030	743	5035	3600			
20	2	223	1051	596	291	1443	840	357	1911	1095	430	2533	1385	NA	NA	NA	NA	NA	NA	NA	NA	NA	NA	NA	NA
	4	230	1162	748	298	1597	1064	365	2116	1395	438	2778	1765	554	3447	2180	661	4190	2630	772	5005	3130			
	6	237	1253	900	307	1726	1288	373	2287	1695	450	2984	2145	567	3708	2650	671	4511	3190	785	5392	3790			
30	2	216	1217	632	286	1664	910	367	2183	1190	461	2891	1540	NA	NA	NA	NA	NA	NA	NA	NA	NA	NA	NA	NA
	4	223	1316	792	294	1802	1160	376	2366	1510	474	3110	1920	619	3840	2365	728	4681	2860	847	5606	3410			
	6	231	1400	952	303	1920	1410	384	2524	1830	485	3299	2340	632	4080	2875	741	4976	3480	860	5961	4150			
50	2	206	1479	689	273	2023	1007	350	2659	1315	435	3548	1665	NA	NA	NA	NA	NA	NA	NA	NA	NA	NA	NA	NA
	4	213	1561	860	281	2139	1291	359	2814	1685	447	3730	2135	580	4601	2633	709	5569	3185	851	6633	3790			
	6	221	1631	1031	290	2242	1575	369	2951	2055	461	3893	2605	594	4808	3208	724	5826	3885	867	6943	4620			
100	2	192	1923	712	254	2644	1050	326	3490	1370	402	4707	1740	NA	NA	NA	NA	NA	NA	NA	NA	NA	NA	NA	NA
	4	200	1984	888	263	2731	1346	336	3606	1760	414	4842	2220	523	5982	2750	639	7254	3330	769	8650	3950			
	6	208	2035	1064	272	2811	1642	346	3714	2150	426	4968	2700	539	6143	3350	654	7453	4070	786	8892	4810			

**Common Vent Capacity**

Vent Height H (ft)		Common Vent Diameter - D (inches)																			
		12"		14"			16"			18"			20"			22"			24"		
		Combined Appliance Input Rating in Thousands of Btu Per Hour																			
		FAN +FAN	FAN +NAT	NAT +NAT	FAN +FAN	FAN +NAT	NAT +NAT	FAN +FAN	FAN +NAT	NAT +NAT	FAN +FAN	FAN +NAT	NAT +NAT	FAN +FAN	FAN +NAT	NAT +NAT	FAN +FAN	FAN +NAT	NAT +NAT	FAN +FAN	FAN +NAT
6	900	696	588	1284	990	815	1735	1336	1065	2253	1732	1345	2838	2180	1660	3488	2677	1970	4206	3226	2390
8	994	773	652	1423	1103	912	1927	1491	1190	2507	1936	1510	3162	2439	1860	3890	2998	2200	4695	3616	2680
10	1076	841	712	1542	1200	995	2093	1625	1300	2727	2113	1645	3444	2665	2030	4241	3278	2400	5123	3957	2920
15	1247	986	825	1794	1410	1158	2440	1910	1510	3184	2484	1910	4026	3133	2360	4971	3862	2790	6016	4670	3400
20	1405	1116	916	2006	1588	1290	2722	2147	1690	3561	2798	2140	4548	3552	2640	5573	4352	3120	6749	5261	3800
30	1658	1327	1025	2373	1892	1525	3220	2558	1990	4197	3326	2520	5303	4193	3110	6539	5157	3680	7940	6247	4480
50	2024	1640	1280	2911	2347	1863	3964	3183	2430	5184	4149	3075	6567	5240	3800	8116	6458	4500	9837	7813	5475
100	2569	2131	1670	3732	3076	2450	5125	4202	3200	6749	5509	4050	8597	6986	5000	10681	8648	5920	13004	10499	7200

## VENT TABLES

### Capacity of Type B Double-Wall Vent with Single-Wall Connectors Serving Two or more Category I Appliances

**TABLE 4**

**Vent Connector Capacity**

Vent Height H (ft)	Connector Rise R (ft)	Vent Connector Diameter - D (inches)																											
		3"			4"			5"			6"			7"			8"			9"			10"						
		Appliance Input Rating Limits in Thousands of Btu Per Hour																											
		FAN			NAT			FAN			NAT			FAN			NAT			FAN			NAT			FAN			NAT
Min	Max	Max	Min	Max	Max	Min	Max	Max	Min	Max	Max	Min	Max	Max	Min	Max	Max	Min	Max	Max	Min	Max	Max	Min	Max	Max	Min	Max	Max
6	1	NR	NR	26	NR	NR	46	NR	NR	71	NR	NR	102	207	223	140	262	293	183	325	373	234	447	463	286				
	2	NR	NR	31	NR	NR	55	NR	NR	85	168	182	123	215	251	167	271	331	219	334	422	281	458	524	344				
	3	NR	NR	34	NR	NR	62	121	131	95	174	198	138	222	273	188	279	361	247	344	462	316	468	574	385				
15	1	NR	NR	29	79	87	52	116	138	81	177	214	116	238	291	158	312	380	208	397	482	266	556	596	324				
	2	NR	NR	34	83	94	62	121	150	97	185	230	138	246	314	189	321	411	248	407	522	317	568	646	387				
	3	NR	NR	39	87	100	70	127	160	109	193	243	157	255	333	215	331	438	281	418	557	360	579	690	437				
30	1	47	60	31	77	110	57	113	175	89	169	278	129	226	380	175	296	497	230	378	630	294	528	779	358				
	2	50	62	37	81	115	67	117	185	106	177	290	152	236	397	208	307	521	274	389	662	349	541	819	425				
	3	54	64	42	85	119	76	122	193	120	185	300	172	244	412	235	316	542	309	400	690	394	555	855	482				
50	1	46	69	33	75	128	60	109	207	96	162	336	137	217	460	188	284	604	245	364	768	314	507	951	384				
	2	49	71	40	79	132	72	114	215	113	170	345	164	226	473	223	294	623	293	376	793	375	520	983	458				
	3	53	72	45	83	136	82	119	221	128	178	353	186	235	486	252	304	640	331	387	816	424	535	1013	518				

**Common Vent Capacity**

Vent Height H (ft)	Common Vent Diameter - D (inches)																				
	4"			5"			6"			7"			8"			9"			10"		
	Combined Appliance Input Rating in Thousands of Btu Per Hour																				
	FAN +FAN	FAN +NAT	NAT +NAT	FAN +FAN	FAN +NAT	NAT +NAT	FAN +FAN	FAN +NAT	NAT +NAT	FAN +FAN	FAN +NAT	NAT +NAT	FAN +FAN	FAN +NAT	NAT +NAT	FAN +FAN	FAN +NAT	NAT +NAT	FAN +FAN	FAN +NAT	NAT +NAT
6	89	78	64	136	113	100	200	158	144	304	244	196	398	310	257	541	429	332	665	515	407
8	98	87	71	151	126	112	218	173	159	331	269	218	436	342	285	592	473	373	730	569	460
10	106	94	76	163	137	120	237	189	174	357	292	236	467	369	309	638	512	398	787	617	487
15	121	108	88	189	159	140	275	221	200	416	343	274	544	434	357	738	599	456	905	718	553
20	131	118	98	208	177	155	305	247	223	463	383	302	606	487	395	824	673	512	1013	808	626
30	145	132	113	236	202	179	350	286	257	533	446	349	703	570	459	958	790	593	1183	952	723
50	159	145	128	268	233	204	406	337	296	622	529	410	833	686	535	1139	954	689	1418	1157	838



**VENT TABLES**

**Capacity of Masonry Chimney with Type B Double-Wall Vent Connectors  
Serving a Single Category I Appliance**

**TABLE 5**

Height/Lateral H L (ft)	Connector Diameter - D (inches)																	
	To be used with chimney areas within the size limits at bottom																	
	Appliance Input Rating in Thousands of Btu Per Hour																	
	3"		4"		5"		6"		7"		8"		9"		10"		12"	
	FAN	NAT	FAN	NAT	FAN	NAT	FAN	NAT	FAN	NAT	FAN	NAT	FAN	NAT	FAN	NAT	FAN	NAT
	Min	Max	Min	Max	Min	Max	Min	Max	Min	Max	Min	Max	Min	Max	Min	Max	Min	Max
6	NR	28	NR	52	NR	86	NR	130	NR	180	NR	247	NR	320	NR	401	NR	581
5	NR	25*	NR	49	NR	82	NR	117	NR	165	NR	231	NR	298	NR	376	NR	561
2	NR	31	NR	61	NR	103	NR	162	NR	221	NR	298	NR	388	NR	491	NR	724
5	NR	28*	NR	57	NR	96	NR	148	NR	204	NR	277	NR	365	NR	466	NR	712
10	NR	25*	NR	50*	NR	87	NR	139	NR	181	NR	263	NR	347	NR	444	NR	668
2	NR	35*	NR	67	NR	114	NR	179	NR	250	NR	336	NR	441	NR	562	NR	841
5	NR	33*	NR	62	NR	107	NR	164	NR	231	NR	313	NR	416	NR	533	NR	828
10	NR	28*	NR	55*	NR	97	NR	153	NR	216	NR	296	NR	394	NR	567	NR	777
15	NR	NR	NR	48*	NR	89*	NR	141	NR	201	NR	281	NR	375	NR	485	NR	742
2	NR	38*	NR	74	NR	124	NR	201	NR	274	NR	375	NR	491	NR	627	NR	953
5	NR	36*	NR	68*	NR	116	NR	184	NR	254	NR	350	NR	463	NR	597	NR	933
10	NR	NR	NR	60*	NR	107*	NR	172	NR	237	NR	332	NR	440	NR	566	NR	879
15	NR	NR	NR	NR	NR	97*	NR	159	NR	220	NR	314	NR	418	NR	541	NR	840
20	NR	NR	NR	NR	NR	83*	NR	148*	NR	206	NR	296	NR	397	NR	513	NR	807
2	NR	41*	NR	82*	NR	137	NR	216	NR	303	NR	421	NR	558	NR	717	NR	1112
5	NR	NR	NR	76*	NR	128*	NR	198	NR	281	NR	393	NR	526	NR	683	NR	1094
10	NR	NR	NR	67*	NR	115*	NR	184*	NR	263	NR	373	NR	500	NR	648	NR	1025
15	NR	NR	NR	NR	NR	107*	NR	171*	NR	243*	NR	353	NR	476	NR	621	NR	981
20	NR	NR	NR	NR	NR	91*	NR	159**	NR	227**	NR	332	NR	450	NR	592	NR	940
30	NR	NR	NR	NR	NR	NR	NR	188**	NR	288**	NR	428**	NR	588**	NR	788**	NR	1212
2	NR	NR	NR	92*	NR	161*	NR	251*	NR	351*	NR	477	NR	633	NR	812	NR	1243
5	NR	NR	NR	NR	NR	151*	NR	230*	NR	323*	NR	445	NR	596	NR	774	NR	1225
10	NR	NR	NR	NR	NR	138*	NR	215**	NR	304**	NR	424**	NR	567	NR	733	NR	1147
15	NR	NR	NR	NR	NR	127*	NR	199**	NR	282**	NR	400**	NR	539**	NR	702	NR	1099
20	NR	NR	NR	NR	NR	NR	NR	185**	NR	264**	NR	376**	NR	511**	NR	669**	NR	1050
30	NR	NR	NR	NR	NR	NR	NR	NR	NR	NR	NR	327**	NR	468**	NR	623**	NR	984
Minimum Internal Area of Chimney Square Inches	12		19		28		38		50		63		78		95		132	
Maximum Internal Area of Chimney Square Inches	49		88		137		198		269		352		445		550		792	

**VENT TABLES**

**Capacity of Masonry Chimney with Single-Wall Vent Connectors  
Serving a Single Category I Appliance**

**TABLE 6**

Height H (ft)		Lateral L (ft)		Connector Diameter - D (inches)													
				To be used with chimney areas within the size limits at bottom													
				Appliance Input Rating in Thousands of Btu Per Hour													
3"		4"		5"		6"		7"		8"		9"		10"		12"	
FAN		FAN		FAN		FAN		FAN		FAN		FAN		FAN		FAN	
NAT		NAT		NAT		NAT		NAT		NAT		NAT		NAT		NAT	
Max		Max		Max		Max		Max		Max		Max		Max		Max	
Min		Min		Min		Min		Min		Min		Min		Min		Min	
6	2	NR	NR	NR	NR	NR	NR	NR	NR	NR	NR	NR	NR	NR	NR	NR	NR
	5	NR	NR	NR	NR	NR	NR	NR	NR	NR	NR	NR	NR	NR	NR	NR	NR
10	2	NR	NR	NR	NR	NR	NR	NR	NR	NR	NR	NR	NR	NR	NR	NR	NR
	5	NR	NR	NR	NR	NR	NR	NR	NR	NR	NR	NR	NR	NR	NR	NR	NR
	10	NR	NR	NR	NR	NR	NR	NR	NR	NR	NR	NR	NR	NR	NR	NR	NR
	15	NR	NR	NR	NR	NR	NR	NR	NR	NR	NR	NR	NR	NR	NR	NR	NR
20	2	NR	NR	NR	NR	NR	NR	NR	NR	NR	NR	NR	NR	NR	NR	NR	NR
	5	NR	NR	NR	NR	NR	NR	NR	NR	NR	NR	NR	NR	NR	NR	NR	NR
	10	NR	NR	NR	NR	NR	NR	NR	NR	NR	NR	NR	NR	NR	NR	NR	NR
	15	NR	NR	NR	NR	NR	NR	NR	NR	NR	NR	NR	NR	NR	NR	NR	NR
	20	NR	NR	NR	NR	NR	NR	NR	NR	NR	NR	NR	NR	NR	NR	NR	NR
30	2	NR	NR	NR	NR	NR	NR	NR	NR	NR	NR	NR	NR	NR	NR	NR	NR
	5	NR	NR	NR	NR	NR	NR	NR	NR	NR	NR	NR	NR	NR	NR	NR	NR
	10	NR	NR	NR	NR	NR	NR	NR	NR	NR	NR	NR	NR	NR	NR	NR	NR
	15	NR	NR	NR	NR	NR	NR	NR	NR	NR	NR	NR	NR	NR	NR	NR	NR
	20	NR	NR	NR	NR	NR	NR	NR	NR	NR	NR	NR	NR	NR	NR	NR	NR
50	2	NR	NR	NR	NR	NR	NR	NR	NR	NR	NR	NR	NR	NR	NR	NR	NR
	5	NR	NR	NR	NR	NR	NR	NR	NR	NR	NR	NR	NR	NR	NR	NR	NR
	10	NR	NR	NR	NR	NR	NR	NR	NR	NR	NR	NR	NR	NR	NR	NR	NR
	15	NR	NR	NR	NR	NR	NR	NR	NR	NR	NR	NR	NR	NR	NR	NR	NR
	20	NR	NR	NR	NR	NR	NR	NR	NR	NR	NR	NR	NR	NR	NR	NR	NR
	30	NR	NR	NR	NR	NR	NR	NR	NR	NR	NR	NR	NR	NR	NR	NR	NR
Minimum Internal Area of Chimney Square Inches		12		19		28		38		50		63		78		95	
Maximum Internal Area of Chimney Square Inches		49		88		137		198		269		352		445		550	

\* See Note 27

## VENT TABLES

### Capacity of Masonry Chimney with Type B Double-Wall Connectors Serving two or more Category I Appliances

**TABLE 7**

**Vent Connector Capacity**

Vent Height H (ft)	Connector Rise R (ft)	Vent Connector Diameter - D (inches)																											
		3"			4"			5"			6"			7"			8"			9"			10"						
		Appliance Input Rating Limits in Thousands of Btu Per Hour																											
		FAN			NAT			FAN			NAT			FAN			NAT			FAN			NAT			FAN			NAT
Min	Max	Max	Min	Max	Max	Min	Max	Max	Min	Max	Max	Min	Max	Max	Min	Max	Max	Min	Max	Max	Min	Max	Max	Min	Max	Max	Min	Max	Max
6	1	24	NR	21	39	62	40	52	106	67	65	194	101	87	274	141	104	370	201	124	479	253	145	599	319				
	2	26	43	28	41	79	52	53	133	85	67	230	124	89	324	173	107	436	232	127	562	330	148	694	378				
	3	27	49	34	42	92	61	55	155	97	69	262	143	91	369	203	109	491	270	129	633	349	151	795	439				
15	1	24	48	23	38	93	44	54	154	74	72	277	114	100	384	174	125	511	229	153	658	297	184	824	375				
	2	25	55	31	39	105	55	56	174	89	74	299	134	103	419	192	128	558	260	156	718	339	187	900	432				
	3	26	59	35	41	115	64	57	189	102	76	319	153	105	448	215	131	597	292	159	760	382	190	960	486				
30	1	24	54	25	37	111	48	52	192	82	69	357	127	96	504	187	119	680	255	145	883	337	175	1115	432				
	2	25	60	32	38	122	58	54	208	95	72	376	145	99	531	209	122	715	287	149	928	378	179	1171	484				
	3	26	64	36	40	131	66	56	221	107	74	392	163	101	554	233	125	746	317	152	968	418	182	1220	535				
50	1	23	52	26	36	116	49	51	209	82	67	405	133	92	582	198	115	798	271	140	1049	362	168	1334	462				
	2	24	59	31	37	127	58	53	225	96	70	421	152	95	604	222	118	827	304	143	1085	400	172	1379	510				
	3	26	64	37	39	135	66	55	237	108	72	435	170	98	624	247	121	854	334	147	1118	439	176	1421	558				

**Common Vent Capacity**

Vent Height H (ft)	Minimum Internal Area of Chimney, Square Inches																									
	12			19			28			38			50			63			78			113				
	Combined Appliance Input Rating in Thousands of Btu Per Hour																									
	FAN	FAN	NAT	FAN	FAN	NAT	FAN	FAN	NAT	FAN	FAN	NAT	FAN	FAN	NAT	FAN	FAN	NAT	FAN	FAN	NAT	FAN	FAN	NAT		
+FAN	+NAT	+NAT	+FAN	+NAT	+NAT	+FAN	+NAT	+NAT	+FAN	+NAT	+NAT	+FAN	+NAT	+NAT	+FAN	+NAT	+NAT	+FAN	+NAT	+NAT	+FAN	+NAT	+NAT	+FAN	+NAT	+NAT
6	NR	74	25	NR	119	46	NR	178	71	NR	257	103	NR	351	143	NR	458	188	NR	582	246	NR	853	NR		
8	NR	80	28	NR	130	53	NR	193	82	NR	279	119	NR	384	163	NR	501	218	NR	636	278	NR	937	408		
10	NR	84	31	NR	138	56	NR	207	90	NR	299	131	NR	409	177	NR	538	236	NR	686	302	NR	1010	454		
15	NR	90	36	NR	152	67	NR	233	106	NR	334	152	NR	467	212	NR	611	283	NR	781	365	NR	1156	546		
20	NR	92	41	NR	159	75	NR	250	122	NR	368	172	NR	508	243	NR	668	325	NR	858	419	NR	1286	648		
30	NR	NR	NR	NR	NR	NR	NR	270	137	NR	404	198	NR	564	278	NR	747	381	NR	969	496	NR	1473	749		
50	NR	NR	NR	NR	NR	NR	NR	NR	NR	NR	NR	NR	NR	620	328	NR	831	461	NR	1089	606	NR	1692	922		

## VENT TABLES

### Capacity of Masonry Chimney with Single-Wall Connectors Serving two or more Category I Appliances

**TABLE 8**

**Vent Connector Capacity**

Vent Height H (ft)	Connector Rise R (ft)	Vent Connector Diameter - D (inches)																											
		3"			4"			5"			6"			7"			8"			9"			10"						
		Appliance Input Rating Limits in Thousands of Btu Per Hour																											
		FAN			NAT			FAN			NAT			FAN			NAT			FAN			NAT			FAN			NAT
Min	Max	Max	Min	Max	Max	Min	Max	Max	Min	Max	Max	Min	Max	Max	Min	Max	Max	Min	Max	Max	Min	Max	Max	Min	Max	Max	Min	Max	Max
6	1	NR	NR	21	NR	NR	39	NR	NR	66	179	191	100	231	271	140	292	366	200	362	474	252	499	594	283				
	2	NR	NR	28	NR	NR	52	NR	NR	84	186	227	123	239	321	172	301	432	231	373	557	299	509	696	331				
	3	NR	NR	34	NR	NR	61	134	153	97	193	258	142	247	365	202	309	491	269	381	634	348	519	793	375				
15	1	NR	NR	23	NR	NR	43	129	151	73	199	271	112	268	376	171	349	502	225	445	646	291	623	808	360				
	2	NR	NR	30	92	103	54	135	170	88	207	295	132	277	411	189	359	548	256	456	706	334	634	884	402				
	3	NR	NR	34	96	112	63	141	185	101	215	315	151	286	439	213	368	586	289	466	755	378	646	945	437				
30	1	NR	NR	24	86	108	47	126	187	80	193	347	124	259	492	183	338	665	250	430	864	330	600	1089	455				
	2	NR	NR	31	91	119	57	132	203	93	201	366	142	269	518	205	348	699	282	442	908	372	613	1145	490				
	3	NR	NR	35	95	127	65	138	216	105	209	381	160	277	540	229	358	729	312	452	946	412	626	1193	521				
50	1	NR	NR	25	85	113	48	124	204	80	188	392	130	252	567	194	328	778	265	417	1022	355	582	1302	537				
	2	NR	NR	31	89	123	57	130	218	94	196	408	149	262	588	218	339	806	298	429	1058	393	596	1346	567				
	3	NR	NR	35	94	131	65	136	231	106	205	422	167	271	607	243	349	831	328	440	1090	431	610	1386	595				

**Common Vent Capacity**

Vent Height H (ft)	Minimum Internal Area of Chimney, Square Inches																							
	12			19			28			38			50			63			78			113		
	Combined Appliance Input Rating in Thousands of Btu Per Hour																							
	FAN +FAN	FAN +NAT	NAT +NAT	FAN +FAN	FAN +NAT	NAT +NAT	FAN +FAN	FAN +NAT	NAT +NAT	FAN +FAN	FAN +NAT	NAT +NAT	FAN +FAN	FAN +NAT	NAT +NAT	FAN +FAN	FAN +NAT	NAT +NAT	FAN +FAN	FAN +NAT	NAT +NAT	FAN +FAN	FAN +NAT	NAT +NAT
6	NR	73	25	NR	118	45	NR	176	71	NR	255	102	NR	348	142	NR	455	187	NR	579	245	NR	846	NR
8	NR	79	28	NR	128	52	NR	190	81	NR	276	118	NR	380	162	NR	497	217	NR	633	277	NR	928	405
10	NR	83	31	NR	136	56	NR	205	89	NR	295	129	NR	405	175	NR	532	234	NR	680	300	NR	1000	450
15	NR	88	36	NR	149	66	NR	230	105	NR	335	150	NR	460	210	NR	602	280	NR	772	360	NR	1139	540
20	NR	90	40	NR	157	74	NR	247	120	NR	362	170	NR	503	240	NR	661	321	NR	849	415	NR	1264	640
30	NR	NR	NR	NR	NR	NR	NR	266	135	NR	398	195	NR	558	275	NR	739	377	NR	957	490	NR	1447	740
50	NR	NR	NR	NR	NR	NR	NR	NR	NR	NR	NR	NR	NR	612	325	NR	821	456	NR	1076	600	NR	1672	910

**TABLE 9****MASONRY CHIMNEY LINER DIMENSIONS  
WITH CIRCULAR EQUIVALENTS**

NOMINAL LINER SIZE INCHES	INSIDE DIMENSIONS IN LINER INCHES	INSIDE DIA. OR EQUIVALENT DIA. INCHES	EQUIVALENT AREA SQ. INCHES
4 x 8	2 1/2 x 6 1/2	4	12.2
		5	19.6
		6	28.3
		7	38.3
8 x 8	6 3/4 x 6 3/4	7.4	42.7
		8	50.3
8 x 12	6 1/2 x 10 1/2	9	63.6
		10	78.5
12 x 12	9 3/4 x 9 3/4	10.4	83.3
		11	95
12 x 16	9 1/2 x 13 1/2	11.8	107.5
		12	113
		14	153.9
16 x 16	13 1/4 x 13 1/4	14.5	162.9
		15	176.7
16 x 20	13 x 17	16.2	206.1
		18	254.4
20 x 20	16 3/4 x 16 3/4	18.2	260.2
		20	314.1
20 x 24	16 1/2 x 20 1/2	20.1	314.2
		22	380.1
24 x 24	20 1/4 x 20 1/4	22.1	380.1
		24	452.3
24 x 28	20 1/2 x 24 1/4	24.1	456.2
28 x 28	24 1/4 x 24 1/4	26.4	543.3
		27	572.5
30 x 30	25 1/2 x 25 1/2	27.9	607
		30	706.8
30 x 36	25 1/2 x 31 1/2	30.9	749.9
		33	855.3
36 x 36	31 1/2 x 31 1/2	34.4	929.4
		36	1017.9

When liner sizes differ dimensionally from those shown in Table 9 equivalent diameters may be determined from published tables for square and rectangular ducts of equivalent carrying capacity or by other engineering methods.

## EXAMPLES USING SINGLE APPLIANCE VENTING TABLES

### Example 1: Single Draft-Hood-Equipped Appliance

Suppose that an installer has a 120,000 Btu/hr input appliance with a 5 inch diameter draft hood outlet that needs to be vented into a 10 foot high Type B vent system. What size vent should be used assuming (a) a 5-Ft lateral single-wall metal vent connector is used with two 90° elbows, (b) a 5-Ft lateral single-wall metal vent connector is used with three 90° elbows in the vent system?

#### Solution

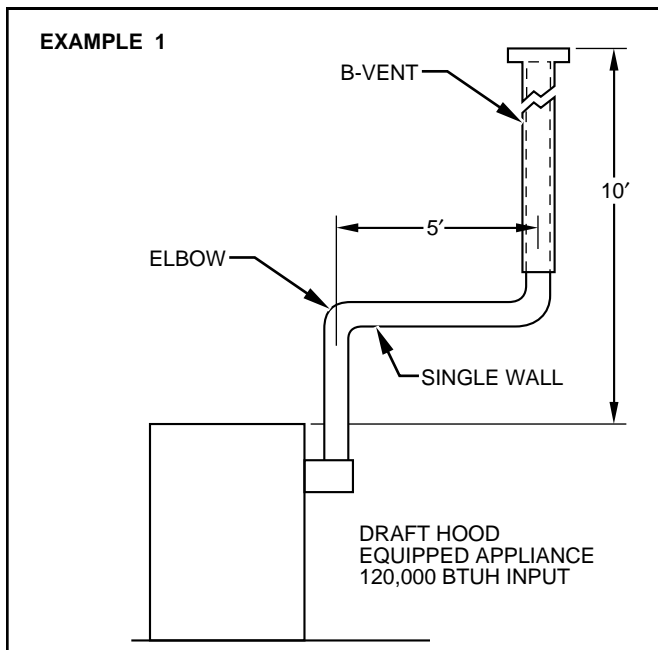
Table 2 should be used to solve this problem because single-wall metal vent connectors are being used with a Type B vent: Refer to Figure 4 of Typical Applications.

- (a) Read down the first column in Table 2 until the row associated with a 10-Ft height and a 5-Ft lateral is found. Read across this row until a vent capacity greater than 120,000 Btu/hr is located in the shaded columns labeled "NAT Max" for draft-hood-equipped appliances. In this case, a 5 inch diameter vent has a capacity of 122,000 Btu/hr and may be used for this application.
- (b) If three 90° elbows are used in the vent system, then the maximum vent capacity listed in the tables must be reduced by 10 percent (see Note 3). This implies that the 5 inch diameter vent has an adjusted capacity of only 110,000 Btu/hr. In this case, the vent system must be increased to 6 inches in diameter. See calculations below:

$$122,000 \times .90 = 110,000 \text{ for } 5'' \text{ Vent}$$

From Table 2—Select 6" Vent

$186,000 \times .90 = 167,000$ ; This is greater than the required 120,000, therefore use a 6" Vent and connector when three elbows are used.



### Example 2: Single Fan-Assisted Appliance

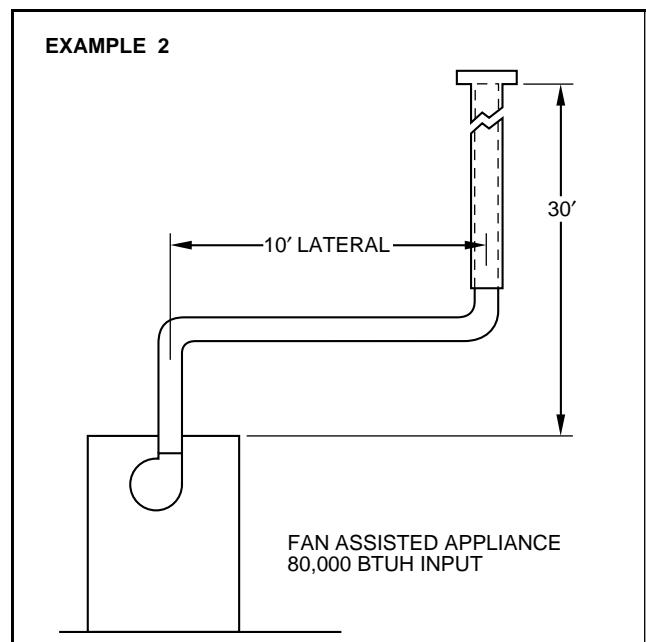
Suppose an installer has an 80,000 Btu/hr input fan-assisted appliance that must be installed using 10 feet of lateral connector attached to a 30-Ft high Type B vent. Two 90° elbows are needed for the installation. Can a single-wall metal vent connector be used for this application?

#### Solution

Table 2 refers to the use of single-wall metal vent connectors with Type B vent. In the first column find the row associated with a 30-Ft height and a 10-Ft lateral. Read across this row, looking at the "FAN Min" and "FAN Max" columns, to find that a 3 inch diameter single-wall metal connector vent is not recommended. Moving to the next larger size single wall connector (4") we find that a 4 inch diameter single-wall metal connector has a recommended minimum vent capacity of 91,000 Btu/hr and a recommended maximum vent capacity of 144,000 Btu/hr. The 80,000 Btu/hr fan-assisted appliance is outside this range, so we conclude that a single-wall metal vent connector cannot be used to vent this appliance using 10 feet of lateral for the connector.

However, we see that if the 80,000 Btu/hr input appliance could be moved to within 5 feet of the vertical vent, then a 4 inch single-wall metal connector could be used to vent the appliance. Table 2 shows the acceptable range of vent capacities for a 4 inch vent with 5 feet of lateral to be between 72,000 Btu/hr and 157,000 Btu/hr.

If the appliance cannot be moved closer to the vertical vent, then Type B vent could be used as the connector material. In this case, Table 1 shows that for a 30-Ft high vent with 10 feet of lateral, the acceptable range of vent capacities for a 4 inch diameter vent attached to a fan-assisted appliance are between 37,000 Btu/hr and 150,000 Btu/hr.



## EXAMPLES USING COMMON VENTING TABLES

### Example 3: Common Venting Two Draft-Hood Appliances

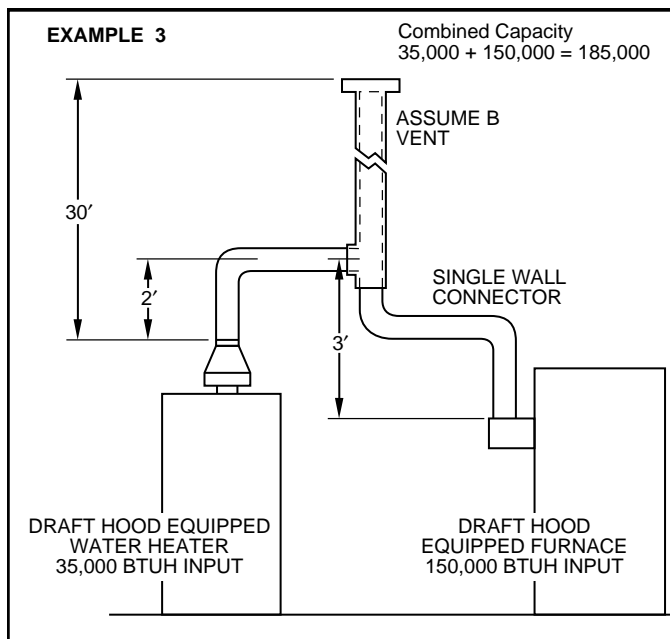
Suppose a 35,000 Btu/hr water heater is to be common vented with a 150,000 Btu/hr furnace using a common vent with a total height of 30 feet. The connector rise is 2 feet for the water heater and 3 feet for the furnace. Assume single-wall metal connectors will be used with Type B vent. What size connectors and combined vent should be used in this installation?

**Solution**—(Table 4 applies in this example)

Table 4 should be used to size single-wall metal vent connectors attached to Type B vertical vent. In the vent connector capacity Table 4, find the row associated with a 30-Ft vent height. For a 2-Ft rise on the vent connector for the water heater, read the shaded columns for draft-hood-equipped appliances to find that a 3 inch diameter vent connector has a capacity of 37,000 Btu/hr.

Therefore, a 3 inch single-wall metal vent connector may be used with the water heater. For a draft-hood-equipped furnace with a 3-Ft rise, read across the appropriate row to find that a 5 inch diameter vent connector has a maximum capacity of 120,000 Btu/hr (which is too small for the furnace) and a 6 inch diameter vent connector has a maximum vent capacity of 172,000 Btu/hr. Therefore, a 6 inch diameter vent connector should be used with the 150,000 Btu/hr furnace.

For the capacity of the combined vent, the lower portion of Table 4 should be used. The combined vent capacity required is 185,000 Btu/hr. Table 4 shows that the combined vent capacity of a 6 inch diameter vent with a 30-Ft vent height is 257,000 Btu/hr. This is more than adequate to handle the 35,000 Btu/hr input water heater and the 150,000 Btu/hr input furnace.



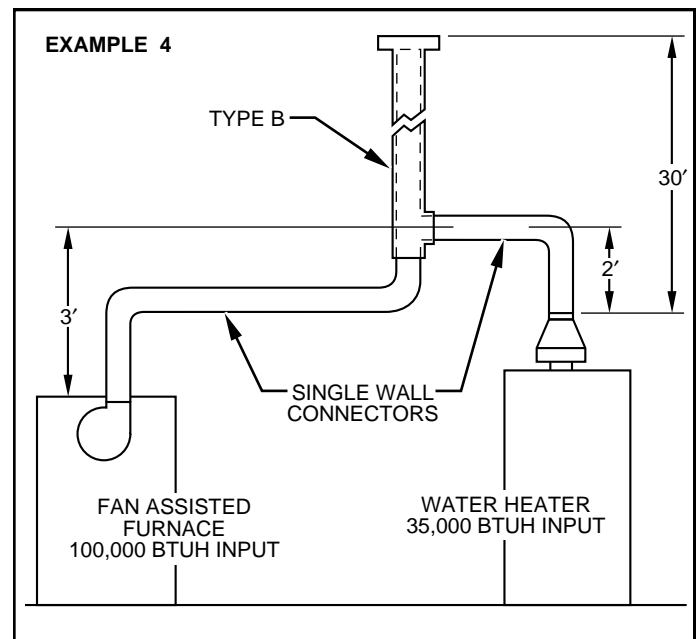
### Example 4: Common Venting a Draft Hood Water Heater with a Fan-Assisted Furnace

In this case, a 35,000 Btu/hr input draft-hood-equipped water heater with a 2 foot connector rise is to be common vented with a 100,000 Btu/hr fan-assisted furnace with a 3-Ft connector rise. The common vent consists of a 30-Ft rise of Type B vent. What are the recommended vent diameters for each connector and the common vent?

**Solution**—(Table 4)

**Water Heater Vent Connector Diameter.** Let us assume the installer would like to use a single-wall metal vent connector. Using Table 4, Vent Connector Capacity, read down the Total Vent Height "H" column to 30 feet and read across the 2-Ft Connector Rise "R" row to the first Btu/hr rating in the "NAT Max" column that is equal to or greater than the water heater input rating. The table shows that a 3 inch vent connector has a maximum input rating of 37,000 Btu/hr. Since this is greater than the water heater input rating, a 3 inch vent connector is adequate. Furthermore, since the water heater is equipped with a draft hood, there are no minimum input rating restrictions.

**Furnace Vent Connector Diameter.** Again, let us assume the installer would like to use a single-wall metal vent connector. Using Table 4, Vent Connector Capacity, read down the Total Vent Height "H" column to 30 feet and across the 3-ft Connector Rise "R" row. Since the furnace has a fan-assisted combustion system, find the first "FAN Max" column with a Btu/hr rating greater than the furnace input rating. The 4 inch vent connector has a maximum input rating of 119,000 Btu/hr and a minimum input rating of 85,000 Btu/hr. The 100,000 Btu/hr furnace in this example falls within this range, so a 4 inch connector is adequate. If the furnace would have had an input rating of 80,000 Btu/hr, then a Type B vent connector (see Table 4) would have to be used in order to meet the minimum capacity limit.



## EXAMPLES USING COMMON VENTING TABLES

### Example 4: (cont'd)

**Common Vent Diameter.** The total input to the common vent is 135,000 Btu/hr. Using Table 4, Common Vent Capacity, read down the Total Vent Height "H" column to 30 feet and across this row to find the smallest vent diameter in the "FAN+NAT" column that has a Btu/hr rating equal to or greater than 135,000 Btu/hr. The 4 inch common vent has a capacity of 132,000 Btu/hr and the 5 inch common vent has a capacity of 202,000 Btu/hr. Therefore, the 5 inch common vent should be used in this example.

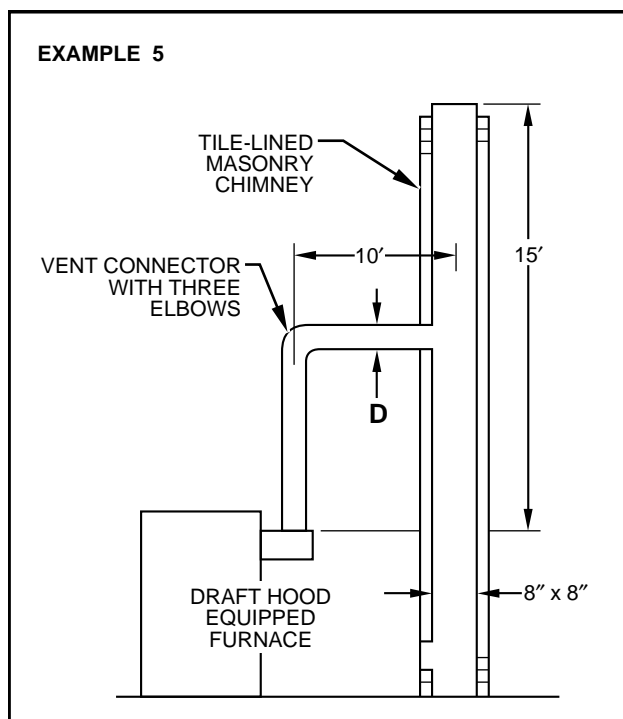
**Summary.** In this example, the installer may use a 3 inch diameter, single-wall metal vent connector for the water heater and a 4 inch diameter, single-wall metal vent connector for the furnace. The common vent should be a 5 inch diameter Type B vent

### Example 5: Single Draft Hood Equipped Furnace Vented into a Masonry Chimney

A 135,000 Btu/hr draft hood equipped furnace is to be vented into a 15' high tile lined masonry chimney. The chimney is not exposed to the outside except above the roof line. The furnace has a 6" diameter draft hood outlet and requires a 10' lateral vent connector with 3 elbows. The chimney is constructed using a 8" x 8" liner. What size single wall vent connector is required?

#### Solution:

Table 6 should be used. Refer to the figure for Example 5.



To determine the required vent connector diameter, read down the height column in Table 6 until 15' is found. Find the row for a 10' long lateral. The table shows that a 6" diameter connector will allow a maximum capacity of 151,000 Btu/hr for "Nat Max." (draft-hood equipped) furnace. Because 3 elbows are required, however, the maximum capacity must be reduced by 10% (See Note 3). Allowing for the additional elbow the corrected maximum capacity is 135,900 Btu/hr. A 6" diameter connector is large enough and should be used. The internal area of the chimney is 8" x 8" = 64 sq. in. and is within the acceptable range (38 sq. in. to 198 sq. in.) for a 6" vent connector as shown in Table 6.

### Example 6: Common Venting into a Masonry Chimney

In this case, a 35,000 Btu/hr input 4 inch diameter outlet draft hood-equipped water heater with 2 feet of connector rise and 4 feet of horizontal length is to be common vented with a 100,000 Btu/hr fan-assisted furnace with a 4 inch diameter flue collar, 3 feet of connector rise and 6 feet of horizontal length. The common vent is an 8 x 12 tile lined chimney that is 30 feet tall. What are the recommended vent diameters for each connector? Is this an acceptable installation?

#### Solution:

Table 8 is used to size common venting installations involving single wall connectors into masonry chimneys.

**Water Heater Vent Connector Diameter.** Using Table 8, Vent Connector Capacity, read down the Total Vent Height "H" column to 30 feet and read across the 2 ft Connector Rise "R" row to the first Btu/hr rating in the "NAT MAX" column that is equal to or greater than the water heater input rating. The Table shows that a 3 inch vent connector has a maximum input of only 31,000 Btu/hr while a 4 inch vent connector has a maximum input of 57,000 Btu/hr. A 4 inch vent connector must therefore be used.

**Furnace Vent Connector Diameter.** Using Table 8 Vent Connector Capacity, read down the Total Vent Height "H" column to 30 feet and across the 3 ft Connector Rise "R" row. Since the furnace has a fan-assisted combustion system, find the first "FAN MAX" column with a Btu/hr rating greater than the furnace input rating. The 4 inch vent connector has a maximum input rating of 127,000 Btu/hr and a minimum input rating of 95,000 Btu/hr. The 100,000 Btu/hr furnace in this example falls within this range, so a 4 inch connector is adequate.



**EXAMPLE 6:** (cont'd)

**Masonry Chimney.** From Table 9, the Equivalent Area for a Nominal Liner size of 8 inches x 12 inches is 63.6 square inches. Using Table 8, Common Vent Capacity, read down the "Fan + Nat" column under the Minimum Internal Area of Chimney value of 63 to the row for 30-ft height, to find a capacity value of 739,000 Btu/hr. The combined input rating of the furnace and water heater 135,000 Btu/hr, is less than the Table value, so this is an acceptable installation.

Note 19 requires the common vent area to be no greater than seven times the flow area of the smallest appliance outlet area. Both appliances in this installation use 4 inch diameter outlets. From Table 9, the Equivalent Area for an Inside Diameter of 4 inches is 12.2 square inches. Seven times 12.2 is 85.4, which is greater than 63.6, so this configuration is acceptable.

Note 1 specifies that the Table values are for vents or chimneys which are not exposed to the outdoors below the roofline. If the masonry chimney in this case were exposed below the roofline, then the appliance manufacturer, local gas utility, and/or authority having jurisdiction must be consulted.

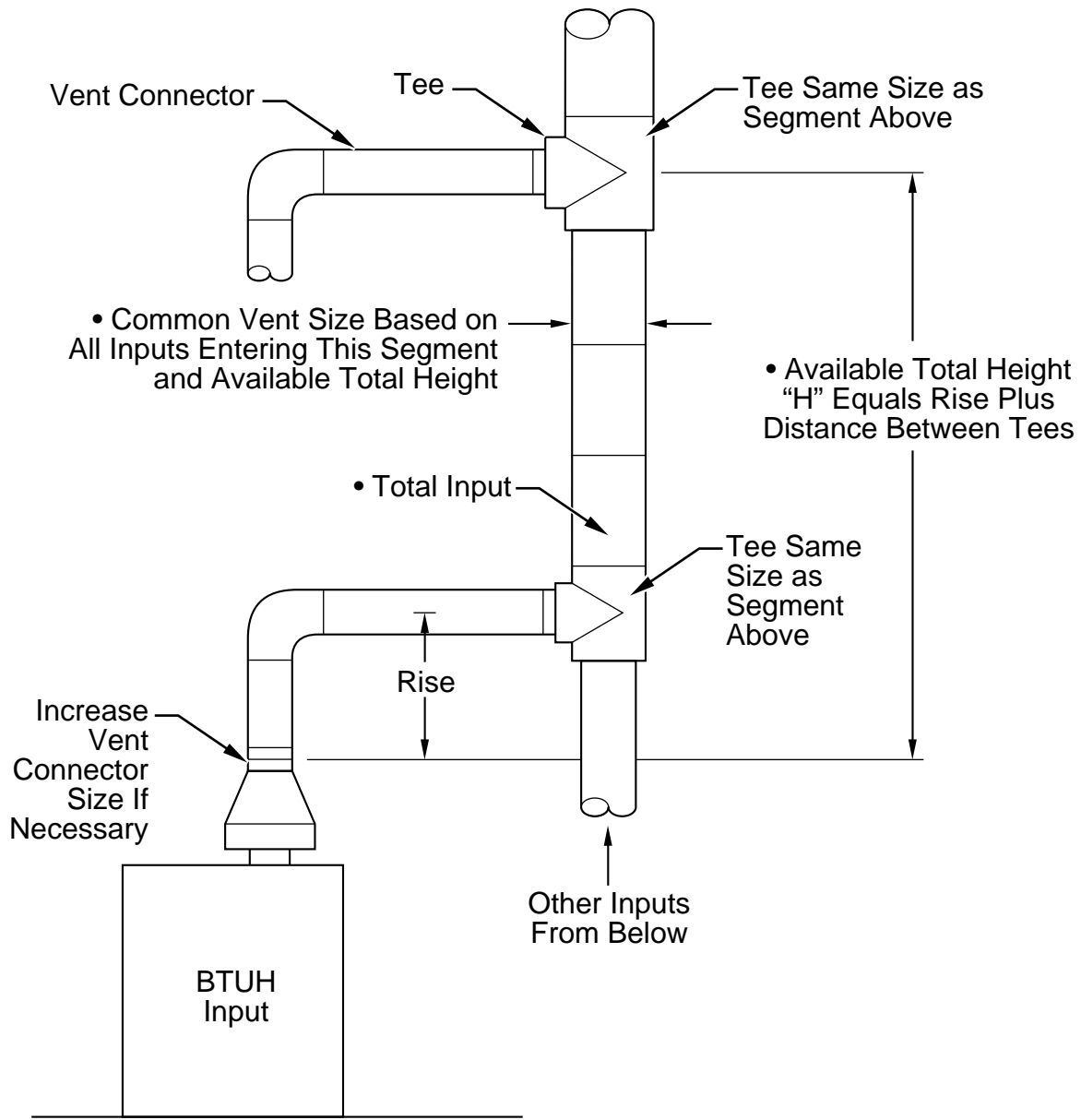
**EXAMPLE 7:** Interpolating Between Table Values

An installer has an 80,000 Btu/hr input appliance with a 4 inch diameter draft hood outlet that needs to be vented into a 12-ft high Type B vent. The vent connector has a 5 ft lateral length and is also Type B. Can this appliance be vented using a 4 inch diameter vent?

**Solution**

Table 1 is used in the case of an all Type B vent system. However, since there is no entry in Table 1 for height of 12 feet, interpolation must be used. Read down the 4 inch diameter "NAT Max" column to the row associated with 10 ft. height and 5 ft. lateral to find the capacity value of 77,000 Btu/hr. Go down further to the 15 ft. height, 5 ft. lateral row to find the capacity value of 87,000 Btu/hr. The difference between the 15 ft. height capacity value and the 10 ft. height capacity value is 10,000 Btu/hr. The capacity for a vent system with a 12 ft. height is equal to the capacity for a 10 ft. height plus  $\frac{2}{5}$  of the difference between the 10 ft. and 15 ft. height values, or  $77,000 + \frac{2}{5} \times 10,000 = 81,000$  Btu/hr. Therefore, a 4 inch diameter vent may be used in the installation.

### Multi-story Gas Vent Design Procedure for Each Segment of System

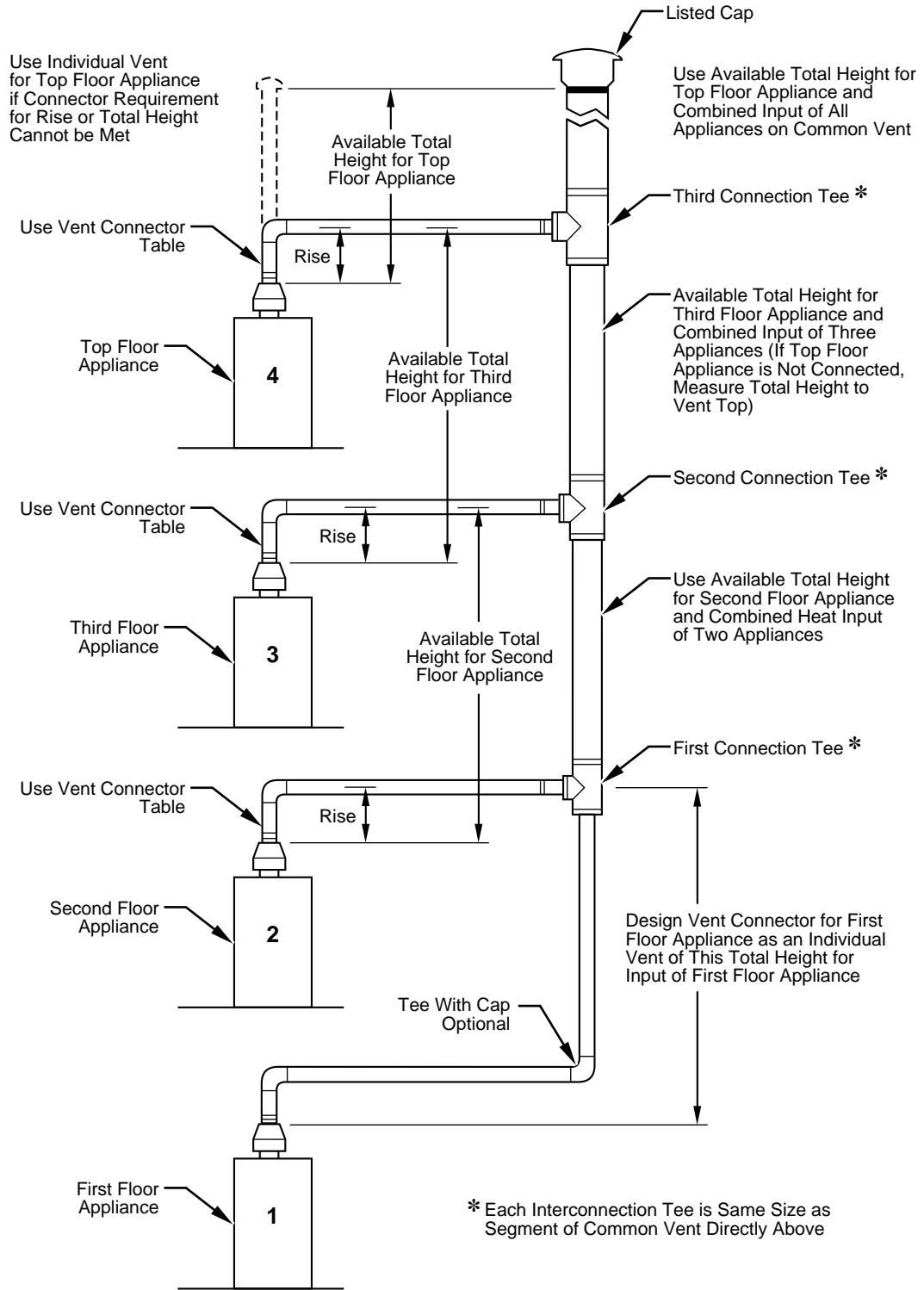


- Vent Connector Size Depends On:
- Input
  - Rise
  - Available Total Height "H"
  - Table 3 Connectors

- Common Vent Size Depends On:
- Combined Inputs
  - Available Total Height "H"
  - Table 3 Common Vent
  - Vertical Common Vent With No Offsets

Figure 13

## Multi-story Vent System



Principles of Design of Multi-story Vents Using Vent Connector and Common Vent Design Tables

**Figure 14**