



BAROMETRIC DRAFT CONTROLS

Model: 4"-7" RC



WARNING: Read the installation instructions carefully and completely before proceeding with the installation.

ITEMS INCLUDED:

Barometric Draft Control

WHEN SHIPPED WITH A COLLAR ADDITIONAL ITEMS:

Mounting straps, Collar, Mounting Hardware

GENERAL INFORMATION

BAROMETRIC DRAFT CONTROLS WITH OR WITHOUT COLLAR

The Field RC is furnished as standard equipment on many leading brands of oil fired heating equipment. It is calibrated to allow for easy adjustment to the furnace or boiler manufactures specifications. Designed for draft settings from .02" to .08" inches of W.C.

CONTROL LOCATIONS

The control should be located as close as possible to a furnace or boiler and positioned as shown in Figure 1. It should be 18" from a stack switch and at least 18" from a combustible ceiling or wall. Do not locate in a room separated from the appliance. **NOTE:** When a sheet metal tee is used instead of the collar, the "B" dimension must not be less than indicated for proper operation. (See Figure 2 and Table 1)

COLLAR INSTALLATION

WHEN SHIPPED WITH A COLLAR

To attach the collar to the flue, see Figure 2 and follow the instructions as follows:

1. Bend the two ears at the front corners of the collar outward. Bend 90°, ¼" behind the single hole on the straps.
2. Insert clamping screw in ears on collar and bolt the remainder of the collar together.
3. Hold the collar against the side of the flue in the exact position it is to be installed (shown by dotted lines) and mark the outline of the collar on the flue.
4. Cut a hole in the flue about ½" inside of the outline.
5. Make a series of cuts about ½" apart from the edge of this hole to the outline marks.
6. Strap the collar to the flue pipe.
7. Bend the tabs formed by the series of cuts outward against the inside of the collar to make a tight joint.
8. Insert the draft control. (See Installation & Adjustment)

If flue pipe is made of material too heavy to bend out into collar, make the diameter of the opening within ½" of the inside diameter of the collar. Seal with high temperature RTV silicone or high temperature foil tape UL listed for the temperature of the application.

For proper settings and operation of the burner and the draft combustion testing instrumentation and draft gauges must be used.

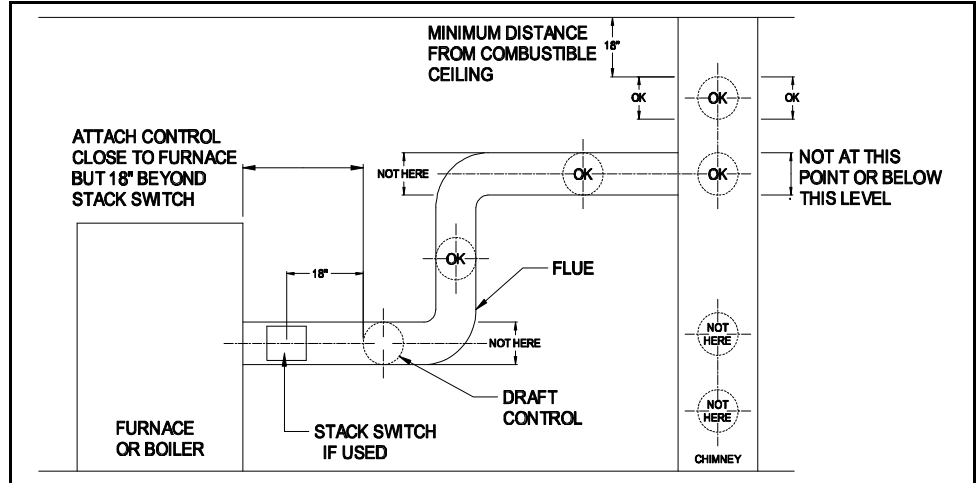

Figure 1

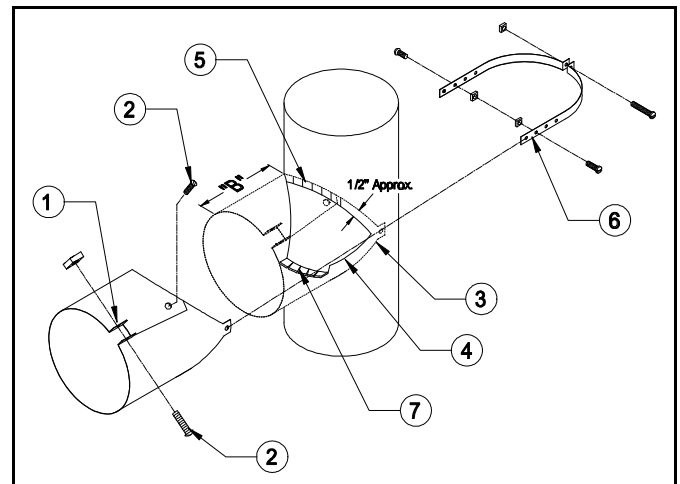

Figure 2



FIELDCONTROLS
THE VENTING SOLUTIONS COMPANY

2630 Airport Road • Kinston, NC 28504
Phone: 252-522-3031 • FAX: 252-522-0214
www.fieldcontrols.com

INSTALLATION AND ADJUSTMENT

NOTE: See sections on control locations and collar installation.

Insert the draft control into the collar. The front face of the control must be plumb. The pivot points must be level whether the control is on a horizontal, vertical, or sloping flue pipe. Use a spirit level, plumb and level accurately. Secure the control in the collar by tightening the clamping screws. If the collar is not supplied by Field, the control may be held in place by small bolts or sheet metal screws so located as not to interfere with the movement of the gate. When a sheet metal TEE is used instead of the collar, the B dimension must not be less than indicated for proper operation. The "B" dimension prevents the damper gate from obstructing the flue passage way. See Figure 2 and Table 1.

VERTICAL FLUES

The control is shipped for installation in a vertical flue. The adjustment weight should be in the right hand slot when you face the control. (See Figure 3)

HORIZONTAL FLUES

For horizontal flues, remove the weight from the right hand slot and attach it to the left hand slot as shown in Figure 3.

ADJUSTING THE CONTROL

The burner must be running when the adjustment of the control is made. The use of a draft gauge is required to accurately set the over fire draft. Set the over fire draft according to the appliance manufactures installation instructions.

Set the control to maintain as low a draft as will give good combustion and meet the requirements for heat. Turn the adjustment weight counter-clockwise to loosen, then slide in slot to the proper position and tighten. The bracket is marked 2,4,6 and 8, which indicates draft settings of .02", .04", etc. (These are drafts in flue adjacent to control, NOT over-fire drafts)

OIL BURNER COMBUSTION AIR AND OVERFIRE DRAFT SETTING (INCHES OF W.C.)

After the burner has operated for at least 5 to 10 minutes, take draft readings over the fire. For a domestic oil burner, the over-fire draft should be approximately .02" to .03", although there are some makes of burners which require higher drafts. Follow the burner manufacturer installation instructions for proper settings. There must always be enough draft so that the burner does not puff back into the room at the moment it starts, and there should be no objectionable smoke. CO₂ and smoke readings must be taken to determine the proper adjustments.

ADDITIONAL APPLICATIONS (FOR RC SERIES DRAFT CONTROLS)

STOKERS

Adjustments must be made while the stoker is running, with a normal fuel bed depth and its fan adjusted to approximately the correct setting.

A draft gauge must be used to accurately set the overfire draft. Follow the manufacture installation instructions for proper settings. If no instructions are available.

For a domestic stoker, the draft should be set at -.04" OVER THE FIRE, with the STOKER ON. Have just enough draft so that at the moment the stoker starts, it does not gas or puff back into the room through cracks around the fire door (with the fire door closed). If there is objectionable smoke, increase draft slightly.

HAND FIRED PLANTS

Adjust the draft control when a good fire is burning. Close any check damper and open wide any internal damper.

Usually a draft of -.06" will be sufficient for cold weather, with reasonably quick pickup after a banked period. But if plant overheats, change to a lower draft setting. Raise the setting if there is not enough heat.

In mild weather when less heat is needed, or the fire is to be banked, close ash pit draft door partly or entirely. If desired, a check damper also can be used when banking the fire.

Table 1

RC SIZE	B-DIMENSION
4	2 1/2 in.
5	2 1/2 in.
6	1 7/8 in.
7	2 5/8 in.

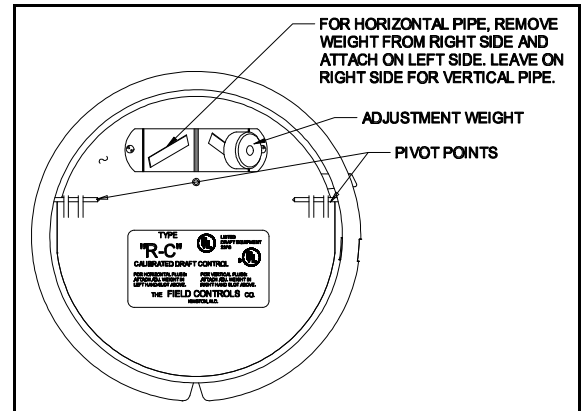

Figure 3