

# Long Line Guideline

## TABLE OF CONTENTS

A. Safety Considerations .....	2
B. Definitions .....	2
C. Introduction .....	2
D. General Limitations .....	3
E. Interconnecting Tubing and Fitting Losses .....	3
F. Metering Device — Long Line Set Cooling .....	4
G. Piston Sizing — Heat Pump Only .....	4
H. Liquid Line Solenoid — Heat Pump Only .....	4
I. Charging Information .....	4
J. General Requirements (Check List) .....	10

## APPLICATIONS

EQUAL-LEVEL APPLICATIONS .....	7
OUTDOOR UNIT BELOW INDOOR UNIT .....	8
OUTDOOR UNIT ABOVE INDOOR UNIT .....	9

## INDEX TO TABLES

TABLE 1	Long Line Accessory Requirements .....	3
TABLE 2	Fitting Losses in Equivalent Feet .....	4
TABLE 3A	Vapor Line Sizing and Cooling Capacity Loss — Single-Stage Air Conditioner Applications .....	5
TABLE 3B	Vapor Line Sizing and Cooling Capacity Loss — Single-Stage Heat Pump Applications .....	5
TABLE 4A	Vapor Line Sizing and Cooling Capacity Loss — Two-Stage Air Conditioner Applications .....	6
TABLE 4B	Vapor Line Sizing and Cooling Capacity Loss — Two-Stage Heat Pump Applications .....	6
TABLE 5	Maximum Total Equivalent Length .....	8
TABLE 6	HP Outdoor Piston Change — Outdoor Unit Below Indoor Unit .....	8
TABLE 7	HP Outdoor Piston Change — Outdoor Unit Above Indoor Unit .....	9
TABLE 8	Common AccuRater™ Piston Sizes Available Through RCD .....	10

## A. Safety Considerations

Only trained service technicians familiar with standard service instructions and training materials should attempt installation, service, and repair of these units. Improper installation, adjustment, alteration, service, maintenance, or use can cause explosion, fire, electrical shock, or other conditions which may cause death, personal injury, or property damage. Consult a qualified installer, service agency, or your distributor or branch for information or assistance. The qualified installer or agency must use factory--authorized kits or accessories when modifying this product. Refer to the individual instructions packaged with the kits or accessories when installing.

Follow all safety codes. Wear safety glasses, protective clothing, and work gloves. Use quenching cloth for brazing operations. Have fire extinguisher available. Read these instructions thoroughly and follow all warnings or cautions included in literature and attached to the unit. Consult local building codes and National Electrical Code (NEC) for special requirements.

Recognize safety information. This is the safety-alert symbol . When you see this symbol on the unit and in instructions or manuals, be alert to the potential for personal injury. Understand these signal words; DANGER, WARNING, and CAUTION. These words are used with the safety-alert symbol. DANGER identifies the most serious hazards which **will** result in severe personal injury or death. WARNING signifies hazards which **could** result in personal injury or death. CAUTION is used to identify unsafe practices which **may** result in minor personal injury or product and property damage. NOTE is used to highlight suggestions which **will** result in enhanced installation, reliability, or operation.

### WARNING

#### ELECTRICAL SHOCK HAZARD

Failure to follow this warning could result in personal injury or death.

All equipment should be installed in accordance with accepted practices and unit Installation Instructions, and in compliance with all national and local codes. Power should be turned off when servicing or repairing electrical components. Extreme caution should be observed when troubleshooting electrical components with power on. Observe all warning notices posted on equipment and in instructions or manuals.

### WARNING

#### EXPLOSION AND PERSONAL SAFETY HAZARD

Failure to follow this warning could result in personal injury, equipment damage or improper operation.

Refrigeration systems contain refrigerant under pressure. Puron® refrigerant (R-410A) systems operate at higher pressure than standard R-22 systems. Use only service equipment and components rated for Puron® refrigerant. Extreme caution should be observed when handling refrigerants. Wear safety glasses and gloves to prevent personal injury. During normal system operations, some components are hot and can cause burns. Rotating fan blades can cause personal injury. Appropriate safety considerations are posted throughout this manual where potentially dangerous techniques are addressed.

Refrigeration systems contain refrigerant under pressure. Extreme caution should be observed when handling refrigerants. Wear safety glasses and gloves to prevent personal injury. During normal system operations, some components are hot and can cause burns. Rotating fan blades can cause personal injury. Appropriate safety considerations are posted throughout this manual where potentially dangerous techniques are addressed.

## B. Definitions

This Guideline covers **all** residential split system air conditioner and heat pump products using Puron® refrigerant **including two-stage models**. Long line and standard applications are defined as follows:

1. An application is “long line” when the actual length of the interconnecting tubing exceeds 80 ft. **or** the vertical separation between indoor and outdoor units exceeds 20 ft..
2. An application is a “standard application” when the actual tubing length is 80 ft. or less, **and** the vertical separation between units is 20 ft. or less.

## C. Introduction

Long line applications are clearly defined in this Guideline, and must be treated differently from standard systems. A long line system requires special consideration for the following reasons:

- Additional refrigerant charge
- Refrigerant migration control
- Oil return concerns
- Capacity losses
- Metering device adjustments

Longer line sets require additional refrigerant charge that must be managed throughout the entire range of possible ambient conditions. Off-cycle migration that results in excess refrigerant in the compressor at start up, or condensed liquid refrigerant in the suction line at start up must be avoided for compressor reliability. Follow all accessory requirements in this Guideline to control off-cycle refrigerant migration (see Table 1).

Another concern is proper line set sizing and construction to control oil return to the compressor and minimize capacity losses. In residential applications, proper line sizing is critical to achieve adequate oil return. Oil return in heating mode is different from cooling

mode thus in some cases heat pumps have additional line set limitations from air conditioning units. This Guideline has separate vapor line sizing charts for single stage and two-stage systems. Some two-stage systems have special limitations unique to the two-stage system. Follow all line sizing recommendations in this Guideline to ensure adequate oil return and compressor lubrication.

The third concern is refrigerant metering. Elevation changes of more than 20 ft., affect pressure drop in refrigerant lines. These effects must be considered when sizing orifice-metering devices. Since all 13 SEER platform units require a TXV for cooling mode metering, this is only a concern for heat pump heating operation. Follow piston change recommendations in this Guideline for proper heat pump heating operation (see Tables 6 & 7).

**NOTE: When an application is “Long Line” the accessories shown in Table 1 are required.**

**D. General Limitations**

Table 2, 3, and 5 include the limits for long line applications. In general:

- Maximum line set actual length is up to 200 ft..
- Maximum line set equivalent length is up to 250 ft.. Some applications have shorter limits (see Table 5).
- Maximum vertical separation for outdoor unit ABOVE indoor unit is 200 ft. (see Fig. 4).
- See Table 5 for maximum vertical separation and allowable total equivalent length when outdoor unit is BELOW indoor unit (see Fig. 3).
  - When outdoor unit is below indoor unit, the maximum total equivalent length varies with the amount of vertical separation and unit size.
- Liquid line size for all applications is 3/8 in. O.D. only.
- See Tables 3a and 3b for allowable vapor line diameters for single-stage systems.
- See Tables 4a and 4b for allowable vapor line diameters and limitations for two-stage systems.
- The maximum length of any buried section of line set is 3 ft. total.

**Table 1 - Long Line Accessory Requirements**

Accessory	Outdoor Unit Above		Outdoor Unit Below		No Elevation Change	
	Air Conditioner	Heat Pump	Air Conditioner	Heat Pump	Air Conditioner	Heat Pump
<b>Liquid line solenoid (LLS) at outdoor</b>	No	Yes KHALS0401LLS	No	Yes KHALS0401LLS	No	Yes KHALS0401LLS
<b>TXV on indoor (Standard on all 13 SEER platform indoor coils and fan coils)</b>	Yes	Yes	Yes	Yes	Yes	Yes
<b>Crankcase heater (if not factory supplied)</b>	Yes	Yes	Yes	Yes	Yes	Yes
<b>Start capacitor and relay</b>	Yes See Product Data for part number	Yes See Product Data for part number	Yes See Product Data for part number	Yes See Product Data for part number	Yes See Product Data for part number	Yes See Product Data for part number
<b>Heating piston change</b>	N/A	Yes see Table 7	N/A	Yes see Table 6	N/A	No
<b>Inverted trap</b>	N/A	N/A	Yes See Fig. 3	Yes See Fig. 3	N/A	N/A

**CAUTION**

**COMPONENT FAILURE HAZARD**

Failure to follow this caution may result in unit component failure.

For proper oil return and minimizing capacity losses, only use vapor line sizes listed in Tables 3a, 3b, 4a and 4b.

**E. Interconnecting Tubing and Fitting Losses**

Choosing the proper tubing diameter is critical for reliable long line applications. **Liquid line diameters in all applications including long line must be 3/8 in. O.D. No other liquid line sizes are permitted.** See Tables 3a and 3b for the allowable vapor tubing diameters for single-stage systems and Table 4a and 4b for two-stage systems. Pay particular attention as some vapor line sizes are acceptable for air conditioners but NOT acceptable for heat pump systems. Two-stage heat pump applications may have limitations that are different from single-stage heat pump applications.

Refrigerant tubing must be measured both in terms of actual length and equivalent length. Use actual length for limitations and refrigerant charge calculation; maximum actual liquid line length allowed is up to 200 ft. Equivalent length takes into account pressure losses from both tubing length and losses due to fittings and accessories, such as elbows, liquid line solenoid and filter drier. Losses from fittings are expressed in equivalent length, meaning the length of straight tubing that would have the same pressure loss as the fitting. See Table 2 for equivalent lengths of commonly used fittings and accessories; maximum equivalent length allowed is up to 250 ft. See Table 4 for maximum total equivalent length.

Calculate total equivalent length by adding linear length of the tubing required and the equivalent length of all elbows used. See Tables 2 and 3 to determine capacity loss of the system due to equivalent length losses and subtract them from the published system capacity for the particular outdoor/indoor unit combination. This data is found in the outdoor unit Product Data.

Example: A 4-ton system using 7/8 in. diameter line set has a total tubing length of 165 ft.. The tubing configuration uses four standard 90° elbows and two 90° long-radius elbows. Checking Table 2, the total equivalent length is calculated as:

165 ft.. straight tubing + (four standard 90° elbows x 2 ft..) + (two long-radius 90° elbows x 1.4 ft..) = 165 ft.. + 8 ft.. + 2.8 ft.. = 175.8 ft.. total equivalent length.

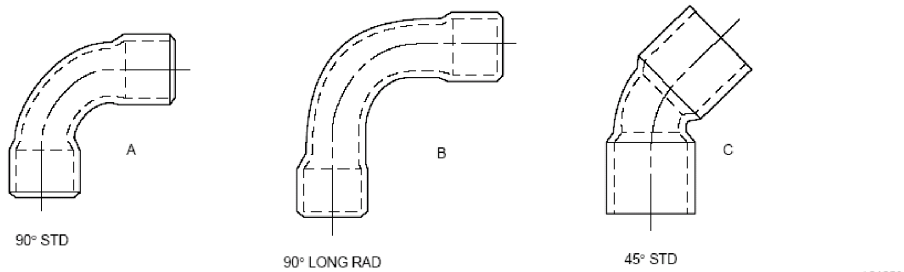

**Fig. 1 – Tube Bend Losses**

**Table 2 - Fitting Losses in Equivalent Feet**

Tube Size O.D. (In.)	Fitting – Reference Diagram in Fig. 1		
	90° Std (A)	90° Long–Rad (B)	45° Std (C)
1/2	1.2	0.8	0.6
5/8	1.6	1.0	0.8
3/4	1.8	1.2	0.9
7/8	2.0	1.4	1.0
1 – 1/8	2.6	1.7	1.3
<b>Liquid Line Solenoid</b>	12		
<b>Filter Drier</b>	6		

#### F. Metering Device — Long Line Cooling

In the new 13 SEER platform, all indoor units must use a hard-shutoff TXV for metering in the cooling mode. This provides adequate refrigerant migration protection for all cooling applications.

#### G. Piston Sizing — Heat Pumps Only

In 13 SEER systems, an AccuRater™ (fixed orifice) is used for refrigerant metering in the heating mode. This fixed expansion device must be changed from the factory-supplied AccuRater™ based on indoor/outdoor vertical separation and system capacity. For horizontal applications up to 200 ft.. linear length and 250 ft.. total equivalent length, no heating piston change is necessary.

When sizing the heating piston for installations where the outdoor unit is below the indoor unit, use Table 6. When outdoor unit is located above indoor unit, use Table 7.

Example: The factory supplied AccuRater™ for a single-stage 3-ton heat pump is a number 57. A system is installed with 200 equivalent ft.. of line set. Approximately 60 ft.. is horizontal and the outdoor unit is 140 ft.. above the indoor unit. Table 7 shows the AccuRater™ piston change to be +6. The new piston size is 57 + 6 = 63. If a 63 is not produced, round up to the next larger available piston size.

On the same heat pump, if the outdoor unit was located 49 ft.. below the indoor unit, Table 6 shows the piston change to be 57 - 2 = 55. If a 55 piston is not produced, round up to the next available size.

#### H. Liquid Line Solenoid — Long Line Heat Pump Heating

Since AccuRater™ do not provide off-cycle refrigerant migration protection in the heating mode, a liquid line solenoid is required for single-stage and two-stage heat pump applications. Bi-flow solenoid valves provide flow control protection only in the direction of the arrow molded into the valve. **The arrow must point toward the outdoor unit** for off-cycle refrigerant control in the heating mode. The arrow shows the direction of flow control. The solenoid should be installed within 2 ft.. of the outdoor unit. The liquid line solenoid kit number for a heat pump is KHALS0401LLS.

**NOTE:** Equivalent length of the liquid line solenoid should be added to the total equivalent length of the tubing. See Table 2.

#### I. Charging Information

Use subcooling as the primary method for charging longline applications. Since the total system charge is increased for long line applications, it is necessary to calculate additional refrigerant charge.

For all long line applications, pressure drop and subcooling loss becomes a concern. In these applications, a **minimum of 10° of subcooling** is required to ensure no refrigerant flashing occurs before the TXV metering device. Systems should be charged to 10° subcooling or the rating plate subcooling, whichever is greater.

Outdoor units are pre-charged at the factory for 15 ft.. of line set and a matched indoor coil. For line lengths greater than 15 ft.., add 0.6 oz.. of refrigerant per foot of additional line length. After the additional charge is added, the charge must be verified by operating the systems in cooling mode for a minimum of 15 min. while the outdoor ambient is greater than 70°. Confirm the subcooling is at least 10° or the value listed on the rating plate. When installing a heat pump in cold conditions, ensure the system is operating near charging chart conditions.

The amount of factory-charge can be found on the unit rating plate or in the Product Data literature. Long line applications do not require additional oil charge.

**Table 3a - Vapor Line Sizing and Cooling Capacity Losses — Puron® Refrigerant 1-Stage Air Conditioner Applications**

Unit Nominal Size (Btuh)	Acceptable Vapor Line Diameters (In. O.D.)	Cooling Capacity Loss (%) Total Equivalent Line Length (ft.)											
		Standard Application			Long Line Application Requires Accessories								
		25	50	80	80+	100	125	150	175	200	225	250	
18,000 1-Stage Puron AC	1/2	1	2	3	3	4	6	7	8	9	10	12	
	5/8	0	0	1	1	1	1	2	2	3	3	3	
24,000 1-Stage Puron AC	5/8	0	1	1	1	2	3	3	4	4	5	6	
	3/4	0	0	0	0	0	1	1	1	1	1	2	
	7/8	0	0	0	0	0	0	0	0	0	0	1	
30,000 1-Stage Puron AC	5/8	1	2	3	3	3	4	5	6	7	8	9	
	3/4	0	0	1	1	1	1	2	2	2	3	3	
	7/8	0	0	0	0	0	1	1	1	1	1	1	
36,000 1-Stage Puron AC	5/8	1	2	4	4	5	6	7	9	10	11	13	
	3/4	0	0	1	1	1	2	2	3	3	4	4	
	7/8	0	0	0	0	0	1	1	1	1	2	2	
42,000 1-Stage Puron AC	3/4	0	1	2	2	2	3	4	4	5	6	6	
	7/8	0	0	1	1	1	1	2	2	2	3	3	
	1-1/8	0	0	0	0	0	0	0	0	0	0	1	
48,000 1-Stage Puron AC	3/4	0	1	2	2	3	4	5	5	6	7	8	
	7/8	0	0	1	1	1	2	2	2	3	3	4	
	1-1/8	0	0	0	0	0	0	0	0	1	1	1	
60,000 1-Stage Puron AC	3/4	1	2	4	4	5	6	7	9	10	11	12	
	7/8	0	1	2	2	2	3	4	4	5	5	6	
	1-1/8	0	0	0	0	1	1	1	1	1	1	2	

Applications in this area are long line. Accessories are required as shown in Table 1.

Applications at 80+ equivalent length and greater in this area are long line. Accessories in Table 1 are required. Additional height restrictions may apply when outdoor unit is below indoor unit. See Table 5.

**Table 3b - Vapor Line Sizing and Cooling Capacity Losses - Puron® Refrigerant 1- Stage Heat Pump Applications**

Unit Nominal Size (Btuh)	Acceptable Vapor Line Diameters (In. O.D.)	Cooling Capacity Loss (%) Total Equivalent Line Length (ft.)											
		Standard Application			Long Line Application Requires Accessories								
		25	50	80	80+	100	125	150	175	200	225	250	
18,000 1-Stage Puron HP	1/2	1	2	3	3	4	6	7	8	9	10	12	
	5/8	0	0	1	1	1	1	2	2	3	3	3	
24,000 1-Stage Puron HP	5/8	0	1	1	1	2	3	3	4	4	5	6	
	3/4	0	0	0	0	0	1	1	1	1	1	2	
30,000 1-Stage Puron HP	5/8	1	2	3	3	3	4	5	6	7	8	9	
	3/4	0	0	1	1	1	1	2	2	2	3	3	
	7/8	0	0	0	0	0	1	1	1	1	1	1	
36,000 1-Stage Puron HP	5/8	1	2	4	4	5	6	7	9	10	11	13	
	3/4	0	0	1	1	1	2	2	3	3	4	4	
	7/8	0	0	0	0	0	1	1	1	1	2	2	
42,000 1-Stage Puron HP	3/4	0	1	2	2	2	3	4	4	5	6	6	
	7/8	0	0	1	1	1	1	2	2	2	3	3	
48,000 1-Stage Puron HP	3/4	0	1	2	2	3	4	5	5	6	7	8	
	7/8	0	0	1	1	1	2	2	2	3	3	4	
60,000 1-Stage Puron HP	3/4	1	2	4	4	5	6	7	9	10	11	12	
	7/8	0	1	2	2	2	3	4	4	5	5	6	
	1-1/8	0	0	0	0	1	1	1	1	1	1	2	

Applications in this area are long line. Accessories are required as shown in Table 1.

Applications at 80+ equivalent length and greater in this area are long line. Accessories in Table 1 are required. Additional height restrictions may apply when outdoor unit is below indoor unit. See Table 5.

**Table 4a - Vapor Line Sizing and Cooling Capacity Losses — Puron® Refrigerant 2-Stage Air Conditioner Applications**

Unit Nominal Size (Btuh)	Acceptable Vapor Line Diameters (In. O.D.)	Cooling Capacity Loss (%) Total Equivalent Line Length (ft.)											
		Standard Application			Long Line Application Requires Accessories								
		25	50	80	80+	100	125	150	175	200	225	250	
24000 2-Stage Puron AC	5/8	0	1	1	1	2	3	3	4	4	5	6	
	3/4	0	0	0	0	0	1	1	1	1	1	2	
	7/8	0	0	0	—	—	—	—	—	—	—	—	
36000 2-Stage Puron AC	5/8	1	2	4	4	5	6	7	9	10	11	13	
	3/4	0	0	1	1	1	2	2	3	3	4	4	
	7/8	0	0	0	0	0	1	1	1	1	2	2	
48000 2-Stage Puron AC	3/4	0	1	2	2	3	4	5	5	6	7	8	
	7/8	0	0	1	1	1	2	2	2	3	3	4	
60000 2-Stage Puron AC	3/4	1	2	4	4	5	6	7	9	10	11	12	
	7/8	0	1	2	2	2	3	4	4	5	5	6	
	1-1/8	0	0	0	0	1	1	1	1	1	1	2	

Applications in this area are long line. Accessories are required as shown in Table 1.

Applications at 80+ equivalent length and greater in this area are long line. Accessories in Table 1 are required. Additional height restrictions may apply when outdoor unit is below indoor unit. See Table 5.

**NOTE:** Dashes (—) represent insufficient oil return to the compressor in heating mode. Use smaller tube diameter in this area.

**Table 4b - Vapor Line Sizing and Cooling Capacity Losses - Puron® Refrigerant 2-Stage Heat Pump Applications**

Unit Nominal Size (Btuh)	Acceptable Vapor Line Diameters (In. O.D.)	Cooling Capacity Loss (%) Total Equivalent Line Length (ft.)											
		Standard Application			Long Line Application Requires Accessories								
		25	50	80	80+	100	125	150	175	200	225	250	
24,000 2-Stage Puron HP	5/8	0	1	1	1	2	3	3	4	4	5	6	
	3/4	0	1	1	1	1	1	1	1	1	1	2	
36,000 2-Stage Puron HP	5/8	1	2	4	4	5	6	7	9	10	11	13	
	3/4	0	0	1	1	1	2	2	3	3	4	4	
48,000 2-Stage Puron HP	3/4	0	1	2	2	3	4	5	5	6	7	8	
	7/8	0	0	1	1	1	2	2	2	3	3	4	
60,000 2-Stage Puron HP	3/4	1	2	4	4	5	6	7	9	10	11	12	
	7/8	0	1	2	2	2	3	4	4	5	5	6	
	1-1/8	0	0	0	—	—	—	—	—	—	—	—	

Applications in this area are long line. Accessories are required as shown in Table 1.

Applications at 80+ equivalent length and greater in this area are long line. Accessories in Table 1 are required. Additional height restrictions may apply when outdoor unit is below indoor unit. See Table 5.

**NOTE:** Dashes (—) represent insufficient oil return to the compressor in heating mode. Use smaller tube diameter in this area.

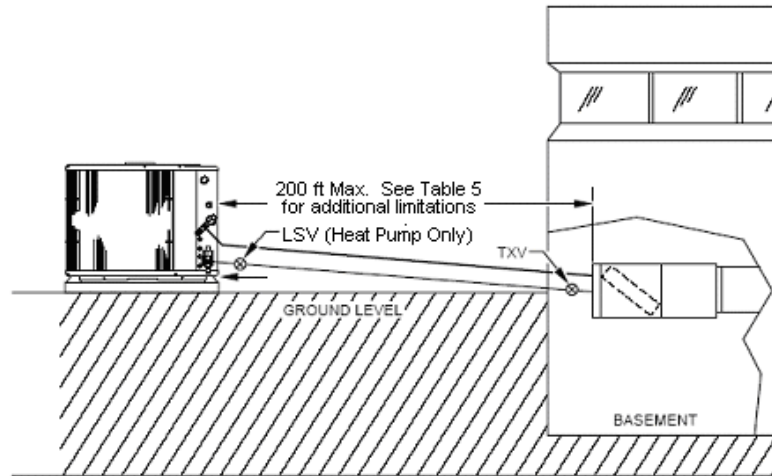

**Fig. 2 – Equal-Level Outdoor/Indoor Unit**

- A hard-shutoff TXV must be installed at indoor unit.
- Hard Start Kit (start capacitor and relay) must be installed on outdoor unit.
- A crankcase heater must be installed on compressor
- Vapor line should slope towards indoor unit
- Maximum actual liquid line length is up to 200 ft..
- Maximum total equivalent length is up to 250 ft..
- Elevation differential must be 20 ft. or less. If greater than 20 ft., see Fig. 3 or 4.
- Heat pump only – Bi-flow liquid line solenoid must be installed within 2 ft. of outdoor unit with arrow pointing towards outdoor unit.
- Heat pump only – Outdoor AccuRater™ adjustment not required
- Use only vapor line sizes listed in Tables 3a , 3b 4a and 4b.
- Use only 3/8 in. liquid line.

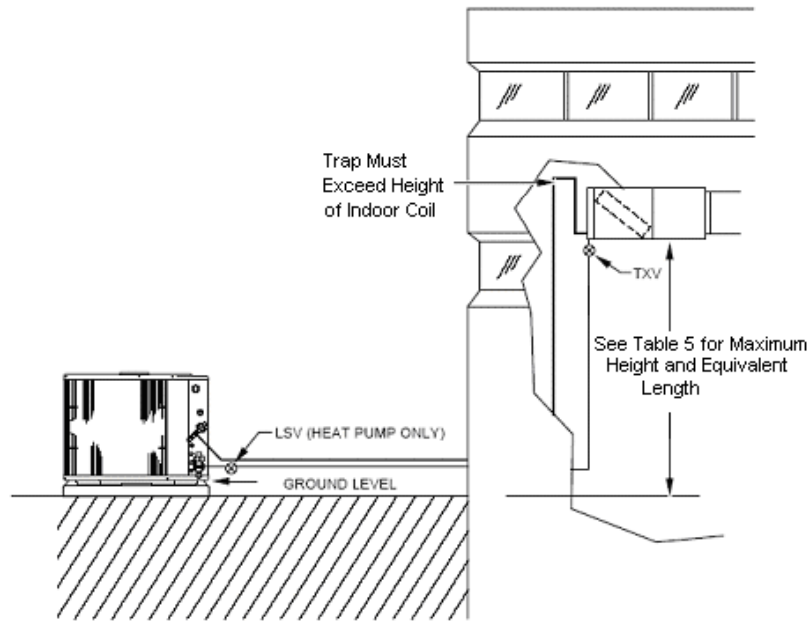

**Fig. 3 – Outdoor Unit Below Indoor Unit**

- Unit must be charged to 10° subcooling or nameplate subcooling, whichever is greater.
- A hard-shutoff TXV must be installed at indoor unit.
- A crankcase heater must be installed on compressor.
- Hard Start Kit (start capacitor and relay) must be installed in outdoor unit.
- An inverted vapor-line trap must be installed at indoor unit. The top peak of trap must be greater than height of indoor coil.
- Maximum actual liquid line length is up to 200 ft. See Table 4 for maximum total equivalent length.
- Elevation differential and line set total equivalent length must not exceed Table 5 requirements.
- Heat pump only – Bi-flow liquid line solenoid must be installed within 2 ft. of outdoor unit with arrow pointing towards outdoor unit.
- Heat pump only – Adjust outdoor piston per Table 6.
- Use only vapor line sizes listed in Tables 3a , 3b 4a and 4b.
- Use only 3/8 in. liquid line.

**Table 5 - Puron® Refrigerant Maximum Total Equivalent Length Outdoor unit BELOW Indoor Unit**

Btuh	Vertical separation (ft.) Outdoor BELOW indoor						
	0-20	21-30	31-40	41-50	51-60	61-70	71-80
18,000	250	250	250	250	250	250	250
24,000	250	250	250	250	250	250	250
30,000	250	250	250	250	250	250	250
36,000	250	250	250	250	250	250	250
42,000	250	250	250	250	250	250	150
48,000	250	250	250	250	230	160	—
60,000	250	225	190	150	110	—	—

NOTE: (—) Indicates vertical separation exceeds allowable limits.

**Table 6 - Puron® Refrigerant Heat Pump Outdoor Piston Change – Outdoor Unit BELOW Indoor Unit**

Btuh	Vertical Separation (ft.) – Outdoor BELOW Indoor Unit						
	0 - 19	20 - 29	30 - 39	40 - 49	50 - 59	60 - 69	70 - 80
18,000	0	-1	-1	-2	-2	-2	-2
24,000	0	-1	-1	-2	-2	-3	-3
30,000	0	-1	-1	-2	-2	-3	-3
36,000	0	-1	-2	-2	-2	-3	-3
42,000	0	-1	-2	-2	-3	-3	-4
48,000	0	-1	-2	-2	-3	-3	—
60,000	0	-1	-2	-3	-3	—	—

NOTE: (—) Indicates vertical separation exceeds allowable limits.

**Example 1:** On a 4 ton system the outdoor unit is 60 ft. below the indoor unit. This is acceptable **only** if the total equivalent length is 230 ft. or less. The heating piston must be resized -3.

**Example 2:** On a 3-ton system the outdoor unit is 80 ft. below the indoor unit. This is acceptable up to 250 ft. total equivalent length. The heating piston must be resized -3.



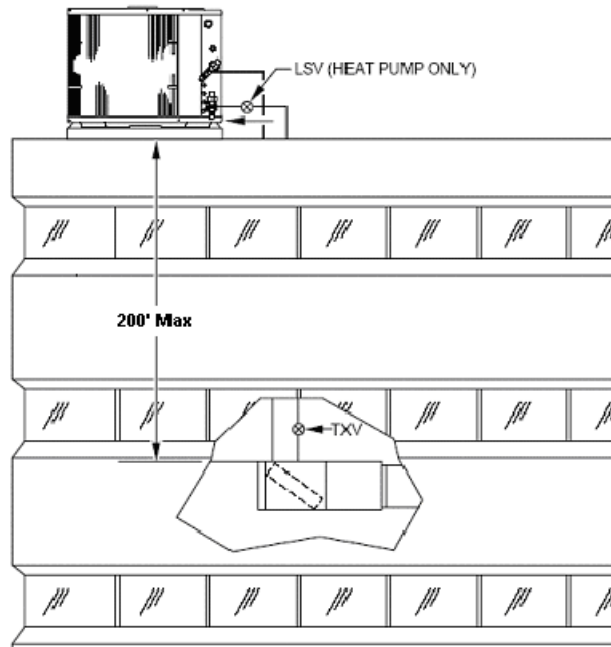

**Fig. 4 – Outdoor Unit Above Indoor Unit**

- A hard-shutoff TXV must be installed at indoor unit.
- A crankcase heater must be installed on compressor.
- Hard Start Kit (start capacitor and relay) must be installed in outdoor unit.
- Heat pump only – Heating piston must be changed as shown in Table 7.
- Maximum actual liquid line length is up to 200 ft..
- Maximum total equivalent length is up to 250 ft..
- Heat pump only – Bi-flow liquid line solenoid must be installed within 2 ft. of outdoor unit with arrow pointing towards outdoor unit.
- Use only vapor line sizes listed in Tables 3a , 3b 4a and 4b.
- Use only 3/8 in. liquid line.

**Table 7 - Heat Pump Outdoor Piston Change - Outdoor Unit ABOVE Indoor Unit**

Btuh	Vertical Separation (ft.) – Outdoor Above Indoor Unit							
	20–25	26–50	51–75	76–100	101–125	126–150	151–175	176–200
18,000	+1	+1	+2	+3	+3	+4	+5	+6
24,000	+1	+1	+2	+3	+4	+5	+6	+7
30,000	+1	+2	+2	+4	+5	+6	+8	+9
36,000	+1	+2	+2	+4	+5	+6	+8	+9
42,000	+1	+2	+3	+4	+5	+7	+8	+10
48,000	+1	+2	+3	+4	+5	+7	+9	+10
60,000	+1	+2	+3	+5	+6	+8	+10	+12

**J. General Requirements (Check List)**

**All Applications**

- Hard-shutoff TXV must be installed at indoor unit.
- Hard Start Kit (start capacitor and relay) must be installed on outdoor unit.
- Crankcase heater must be installed on compressor.
- Use only 3/8 in. O.D. liquid line.
- Use only vapor line sizes listed in Tables 2 and 3.
- Add 0.6 oz. of refrigerant per ft. of actual line length beyond 15 ft..
- Charge system to 10° subcooling or rating plate subcooling, whichever is greater.

**Heat Pumps Only**

- Bi-flow liquid line solenoid must be installed within 2 ft. of outdoor unit with arrow pointing towards outdoor unit.

**Equal-level Outdoor/Indoor unit**

- Outdoor unit and indoor unit must be within +/- 20 ft. vertical separation.
- Vapor line should slope towards indoor unit.

**Heat Pumps Only**

- No outdoor AccuRater™ adjustment required with less than 20 ft. vertical separation.

**Outdoor unit BELOW indoor unit**

- Indoor unit greater than 20 ft. above outdoor unit.
- An inverted vapor-line trap must be installed at indoor unit. The top peak of trap must be greater than height of indoor coil. See Fig. 3.
- Vertical separation and line set equivalent length must not exceed Table 5 requirements.

**Heat Pumps Only**

- Adjust outdoor AccuRater™ per Table 6.

**Outdoor unit ABOVE indoor unit**

- Maximum vertical separation is 200 ft..
- Maximum actual line length is 200 ft..
- Maximum total equivalent length is 250 ft..
- Outdoor unit greater than 20 ft. above indoor unit.

**Heat Pumps Only**

- Adjust outdoor AccuRater™ per Table 7.

**Table 8 - Common AccuRater™ - Piston Sizes Available through RCD  
(Part numbers are all EA52PHxxx. The last 3 digits represent size.)**

EA52PH032	063	093
035	065	096
037	067	098
038	068	101
040	070	104
042	073	106
043	076	109
046	078	110
049	080	113
052	082	116
055	084	120
057	086	125
059	088	128
061	090	

## K. Air Conditioner and Heat Pump with Puron® Refrigerant — Quick Reference Guide

Observe all **warnings, cautions, and bold** text.

Puron® refrigerant (R-410A) refrigerant cylinders are rose colored.

Puron® refrigerant systems operates at 50 percent to 70 percent higher pressures than R-22. Be sure that servicing equipment and replacement components are designed to operate with Puron® refrigerant.

Recovery cylinder service pressure rating must be 400 psig, DOT 4BA400 or DOT BW400.

Puron® refrigerant systems should be charged with liquid refrigerant. Use a commercial type metering device in the manifold hose when charging into suction line with compressor operating..

Manifold sets should be 700 psig high side and 180 psig low side with 550 psig low-side retard.

Use hoses with 700 psig service pressure rating.

Leak detectors should be designed to detect HFC refrigerant.

Vacuum pumps will not remove moisture from oil.

Only use factory specified liquid-line filter driers with rated working pressures of 600 psig or greater.

Do not install a suction-line filter drier in liquid-line.

Puron® refrigerant, as with other HFCs, is only compatible with POE oils.

POE oils absorb moisture rapidly. Do not expose oil to atmosphere.

POE oils may cause damage to certain plastics and roofing materials.

Wrap all filter driers and service valves with wet cloth when brazing.

A factory approved, liquid-line filter drier is required on every unit.

Do not use R-22 TXV on a Puron® refrigerant system.

Never open system to atmosphere while it is under a vacuum.

When system must be opened for service, recover refrigerant, break vacuum with dry nitrogen before opening system.

Always replace filter drier after opening system for service.

Do not vent Puron® refrigerant into the atmosphere.

Do not use capillary tube coils.

All 13 SEER platform systems must have indoor TXV.

Do not leave Puron® refrigerant suction line driers in place for more than 72 hr.

