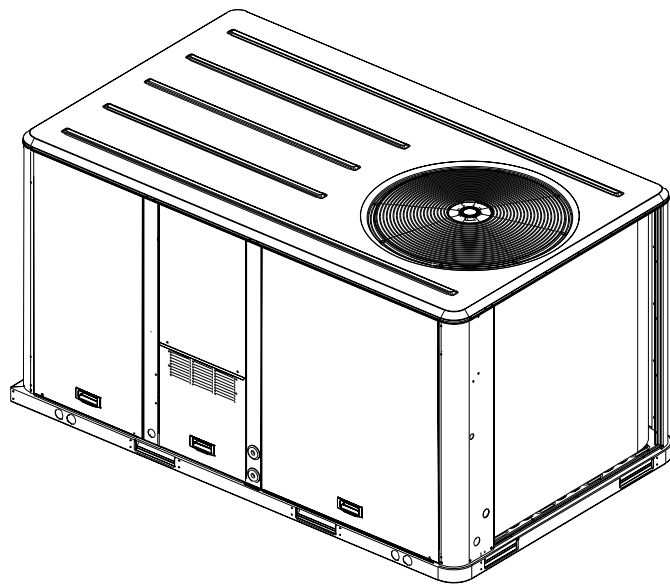


# Wiring Manual

---

**Packaged Gas/Electric  
with Electromechanical Controls**

**3 - 10 Tons**



**Models:**

**(60 Hz)**

YSC036A\*E - YSC120A\*E

YHC033A\*E - YHC120A\*E

# Introduction

---

## Literature Change History

**Y\_C-SVE-001A-EN (Nov. 2003)**  
Updated wiring diagrams.

**Y\_C-SVE-001B-EN (Jan. 2005)**  
Updated wiring diagrams.

## Overview of Manual

This manual provides wiring diagrams for unit models listed on the front page. Refer to the Table of Contents for proper wiring diagrams.

### **NOTICE:**

Warnings and Cautions appear at appropriate sections throughout this manual. Read these carefully.



**WARNING**– Indicates a potentially hazardous situation which, if not avoided, could result in death or serious injury.



**CAUTION** – Indicates a potentially hazardous situation which, if not avoided, may result in minor or moderate injury. It may also be used to alert against unsafe practices.

**CAUTION** – Indicates a situation that may result in equipment or property-damage-only accidents.

# Contents

Literature Change History .....	2		
Warnings and Cautions .....	2		
Model Number Description .....	5		
<b>Power Schematics</b>			
Diagram 1 .....	6	Diagram 11 .....	26
Power Schematic - 230v/60hz/1ph		Power Schematic - 460-575v/60hz/3ph	
2 - 5 Ton Single Stage Gas Heat / Direct Drive Motor		7.5 - 10 Ton Gas Heat / Dual Compressor	
4366-1002		4366-1034	
Diagram 2 .....	8	<b>Connection Schematics</b>	
Power Schematic - 230v/60hz/1ph		Diagram 12 .....	28
2 - 5 Ton Single Stage Gas Heat / Oversize Drive Motor		Connection Schematic - 230v/60hz/1ph	
4366-1018		Single Stage Gas Heat / Direct Drive	
Diagram 3 .....	10	4366-1500	
Power Schematic - 230v/60hz/3ph		Diagram 13 .....	30
2 - 5 Ton Single Stage Gas Heat / Direct Drive Motor		Connection Diagram - 230v/60hz/1ph	
4366-1000		Single Stage Gas Heat / Oversize Motor	
Diagram 4 .....	12	4366-1519	
Power Schematic - 230v/60hz/3ph		Diagram 14 .....	32
2 - 5 Ton Single Stage Gas Heat / Oversize Drive Motor		Connection Diagram - 230v/60hz/3ph	
4366-1017		Single Stage Gas Heat / Direct Drive	
Diagram 5 .....	14	4366-1502	
Power Schematic - 230v/60hz/3ph		Diagram 15 .....	34
2 - 7.5 Ton Single Stage Gas Heat / Belt Drive Motor		Connection Diagram - 230v/60hz/3ph	
4366-1016		Single Stage Gas Heat / Oversize Motor	
Diagram 6 .....	16	4366-1525	
Power Schematic - 230v/60hz/3ph		Diagram 16 .....	36
7.5 - 10 Ton Gas Heat / Dual Compressor		Connection Diagram - 230v/60hz/3ph	
4366-1033		Single Stage Gas Heat / Belt Drive	
Diagram 7 .....	18	4366-1521	
Power Schematic - 460-575v/60hz/3ph		Diagram 17 .....	38
2 - 3 Ton Single Stage Gas Heat / Direct Drive Motor		Connection Diagram - 230v/60hz/3ph	
4366-1004		6 - 7.5 Ton Gas Heat / Single Compressor	
Diagram 8 .....	20	4366-1537	
Power Schematic - 460-575v/60hz/3ph		Diagram 18 .....	40
4 - 5 Ton Single Stage Gas Heat / Direct Drive Motor		Connection Diagram - 230v/60hz/3ph	
4366-1032		7.5 - 10 Ton Gas Heat / Dual Compressor	
Diagram 9 .....	22	4366-1529	
Power Schematic - 460-575v/60hz/3ph		Diagram 19 .....	42
4 - 5 Ton Single Stage Gas Heat / Oversize Drive Motor .		Connection Diagram - 460-575v/60hz/3ph	
4366-1011		2 - 3 Ton Single Stage Gas Heat / Direct Drive	
Diagram 10 .....	24	4366-1513	
Power Schematic - 460-575v/60hz/3ph		Diagram 20 .....	44
2 - 7.5 Ton Single Stage Gas Heat / Belt Drive Motor		Connection Diagram - 460-575v/60hz/3ph	
4366-1005		4 - 5 Ton Single Stage Gas Heat / Direct Drive	
		4366-1517	
		Diagram 21 .....	46
		Connection Diagram - 460-575v/60hz/3ph	
		4 - 5 Ton Single Stage Gas Heat / Oversize Motor	
		4366-1526	

# Contents

---

Diagram 22 .....	48
Connection Diagram - 460-575v/60hz/3ph Single Stage Gas Heat / Belt Drive 4366-1523	
Diagram 23 .....	50
Connection Diagram - 460-575v/60hz/3ph 6 - 7.5 Ton Gas Heat / Single Compressor 4366-1538	
Diagram 24 .....	52
Connection Diagram - 460-575v/60hz/3ph 7.5 - 10 Ton Gas Heat / Dual Compressor 4366-1531	
<b>Control Schematics</b>	
Diagram 25 .....	54
Control Schematic Single Stage Gas Heat / Direct Drive 4366-1001	
Diagram 26 .....	56
Control Schematic 2 - 5 Ton Single Stage Gas Heat / Belt Drive or Oversize Motor 4366-1027	
Diagram 27 .....	58
Control Schematic 6 - 7.5 Ton Gas Heat / Single Compressor 4366-1045	
Diagram 28 .....	60
Control Schematic 7.5 - 10 Ton Gas Heat / Dual Compressor 4366-1039	
<b>Through The Base Utilities Schematic</b>	
Diagram 29 .....	62
Through The Base Utilities 4366-1031	

# Model Number Description

**Y S C 036 A 3 R L A \* C 0 0 0 C 1 0 0 0 1 A 1**  
**1 2 3 4,5,6 7 8 9 10 11 12,13 14 15 16 17 18 19 20 21 22 23 24 25**

## DIGIT 1 - Unit Function

Y = DX Cooling, Gas Heat

## DIGIT 2 - Efficiency

S = Standard Efficiency  
 H = High Efficiency

## DIGIT 3 - Airflow

C = Convertible

## DIGITS 4,5,6 - Nominal Gross Cooling

### Capacity (MBh)

033 = 3-Ton  
 036 = 3-Ton  
 043 = 4-Ton  
 048 = 4-Ton  
 060 = 5-Ton  
 063 = 5-Ton  
 072 = 6-Ton  
 090 = 7½-Ton, Single Compressor  
 092 = 7½-Ton, Dual Compressors  
 102 = 8½-Ton  
 120 = 10-Ton

## DIGIT 7 - Major Design Sequence

A = First

## DIGIT 8 - Unit Voltage

1 = 208-230/60/1  
 3 = 208-230/60/3  
 4 = 460/60/3  
 W = 575/60/3  
 K = 380/60/3

## DIGIT 9 - Unit Controls

E = Electromechanical  
 R = ReliaTel™ Microprocessor

## DIGIT 10 - Heating Capacity

L = Low  
 M = Medium  
 H = High  
 X = Low, Stainless Steel Heat Exchanger  
 Y = Medium, Stainless Steel Heat Exchanger  
 Z = High, Stainless Steel Heat Exchanger

## DIGIT 11 - Minor Design Sequence

A = First Sequence

## DIGITS 12, 13 - Service Sequence

\*\* = Factory Assigned

## DIGIT 14 - Fresh Air Selection

0 = No Fresh Air  
 A = Manual Outside Air Damper 0-50%  
 B = Motorized Outside Air Damper 0-50%  
 C = Economizer, Dry Bulb 0-100% without Barometric Relief  
 D = Economizer, Dry Bulb 0-100% with Barometric Relief  
 E = Economizer, Reference Enthalpy 0-100% without Barometric Relief  
 F = Economizer, Reference Enthalpy 0-100% with Barometric Relief  
 G = Economizer, Comparative Enthalpy 0-100% without Barometric Relief  
 H = Economizer, Comparative Enthalpy 0-100% with Barometric Relief

## DIGIT 15 - Supply Fan/Drive Type/Motor

0 = Standard Drive  
 1 = Oversized Motor  
 2 = Optional Belt Drive Motor

## DIGIT 16 - Hinged Service Access Filters

0 = Standard Panels/Standard Filters  
 A = Hinged Access Panels/Standard Filters  
 B = Standard Panels/2" Pleated Filters  
 C = Hinged Access Panels/2" Pleated Filters

## DIGIT 17 - Condenser Coil Protection

0 = Standard Coil  
 1 = Standard Coil with Hail Guard  
 2 = Epoxy Coated Condenser Coil  
 3 = Epoxy Coated Condenser Coil with Hail Guard

## DIGIT 18 - Through the Base Provisions

0 = No Through the Base Provisions  
 A = Through the Base Electric  
 B = Through the Base Gas Piping  
 C = Through the Base Electric and Gas Piping

## DIGIT 19 - Disconnect/Circuit Breaker (3 phase only)

0 = No Disconnect or Circuit Breaker  
 1 = Non-Fused Disconnect

2 = Circuit Breaker

## DIGIT 20 - Convenience Outlet

0 = No Convenience Outlet  
 A = Unpowered Convenience Outlet  
 B = Powered Convenience Outlet (3 phase only)

## DIGIT 21 - Communications Options

0 = No Communications Interface  
 1 = Trane Communications Interface  
 2 = LonTalk® Communications Interface  
 3 = Novar 2024 Controls  
 4 = Novar 3051 Controls

## DIGIT 22 - Refrigeration System Option

0 = Standard Refrigeration System  
 A = Thermal Expansion Valve (TXV)  
 B = Dehumidification (Hot Gas Reheat Coil)

## DIGIT 23 - Refrigeration Controls

0 = No Refrigeration Control  
 1 = High Pressure Control  
 2 = Froststat  
 3 = Crankcase Heater  
 4 = High Pressure Control and Froststat  
 5 = High Pressure Control and Crankcase Heater  
 6 = Froststat and Crankcase Heater  
 7 = High Pressure Control, Froststat and Crankcase Heater

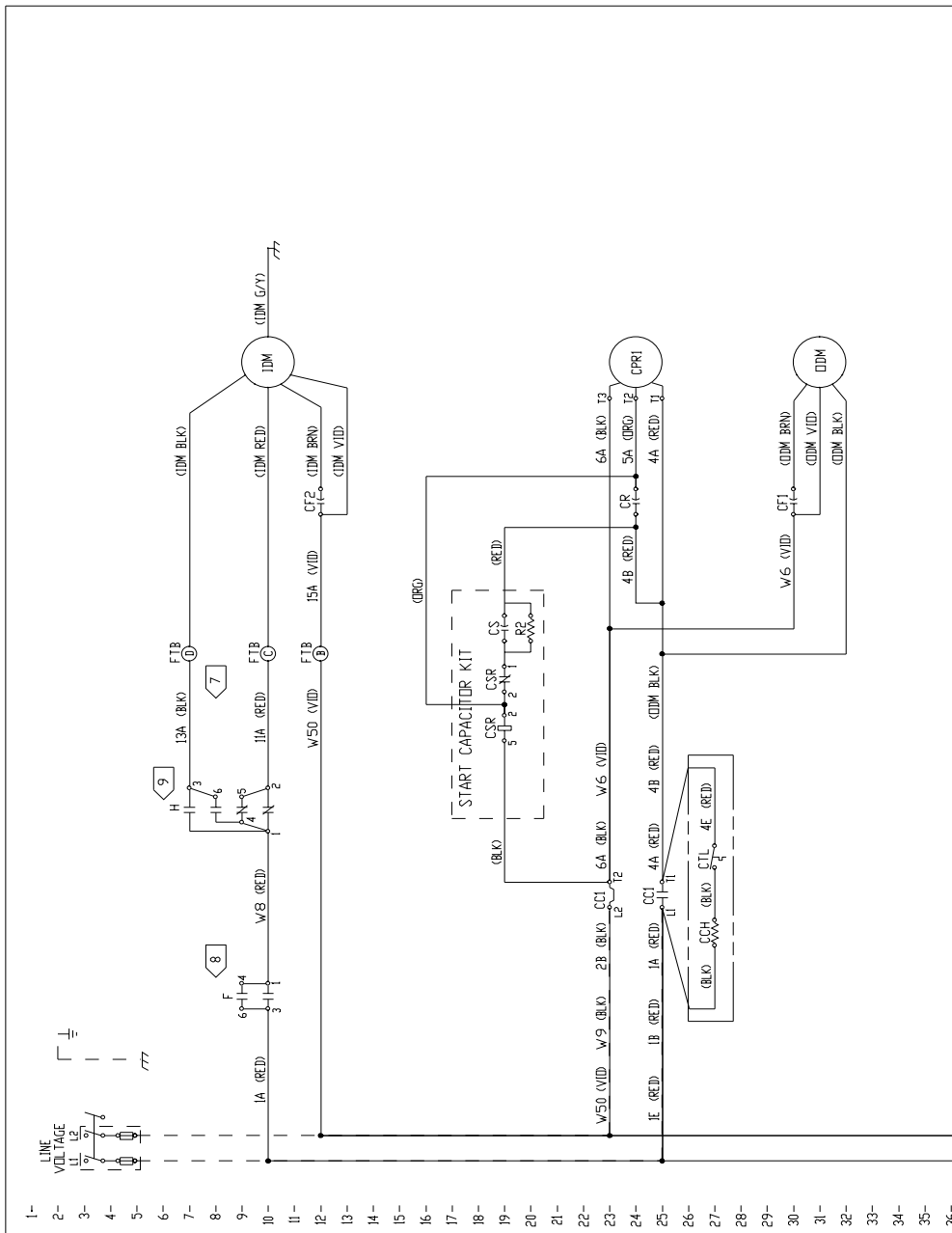
## DIGIT 24 - Smoke Detector

0 = No Smoke Detector  
 A = Return Air Smoke Detector  
 B = Supply Air Smoke Detector  
 C = Supply and Return Air Smoke Detectors

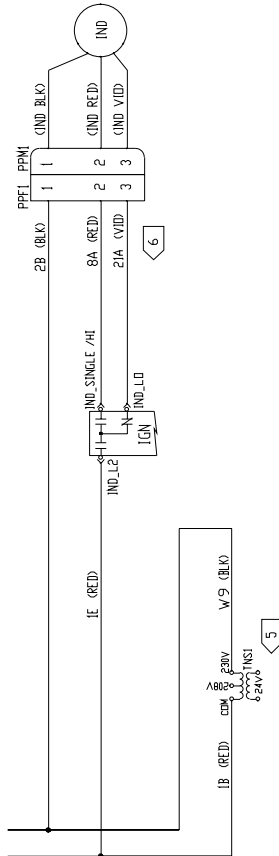
## DIGIT 25 - Monitoring Controls

0 = No Monitoring Control  
 1 = Clogged Filter Switch  
 2 = Fan Failure Switch  
 3 = Discharge Air Sensing Tube  
 4 = Clogged Filter Switch and Fan Fail Switch  
 5 = Clogged Filter Switch and Discharge Air Sensing Tube  
 6 = Fan Fail Switch and Discharge Air Sensing Tube  
 7 = Clogged Filter and Fan Fail Switches and Discharge Air Sensing Tube  
 8 = Novar Return Air Sensor

**Diagram 1**  
**Power Schematic - 230v/60hz/1ph**  
**2 - 5 Ton Single Stage Gas Heat / Direct Drive Motor**  
**4366-1002**



36-  
37-  
38-  
39-  
40-  
41-  
42-  
43-  
44-  
45-  
46-  
47-  
48-  
49-  
50-  
51-  
52-  
53-  
54-  
55-  
56-  
57-  
58-  
59-  
60-  
61-  
62-  
63-  
64-  
65-  
66-  
67-  
68-  
69-  
70-  
71-  
72-  
73-  
74-  
75-  
76-  
77-  
78-



REF	DESCRIPTION	LINE
CCT	COMPRESSOR CONTACTOR	23,25
CCH	CRANKCASE HEATER	27
CFL	OD MOTOR CAPACITOR	30
CF2	ID FAN CAPACITOR	32
CP1	COMPRESSOR	24
CR	CPR RUN CAPACITOR	24
CS	CPR START CAPACITOR	19
CSR	CPR START RELAY	19
CTL	COIL TEMP LIMIT SWITCH	27
F	ID FAN RELAY	9,10
FTB	FAN TERMINAL BLOCK	7,10,12
H	HEAT RELAY	7-10
IDM	ID FAN MOTOR	10
IGN	IGNITION MODULE	40
IND	INDUCER BLOWER	40
IDM	ID FAN MOTOR	31
R2	CPR START RESISTOR	20
TNS1	LOW VOLTAGE TRANSFORMER	45

COLOR	ABBR.	COLOR	ABBR.
BLACK	BLK	ORANGE	DRG
BLUE	BLU	RED	RED
BROWN	BRN	VIOLET (PURPLE)	VIO
GRAY (SLATE)	GRA	WHITE	WHT
GREEN/YELLOW	G/Y	YELLOW	YEL

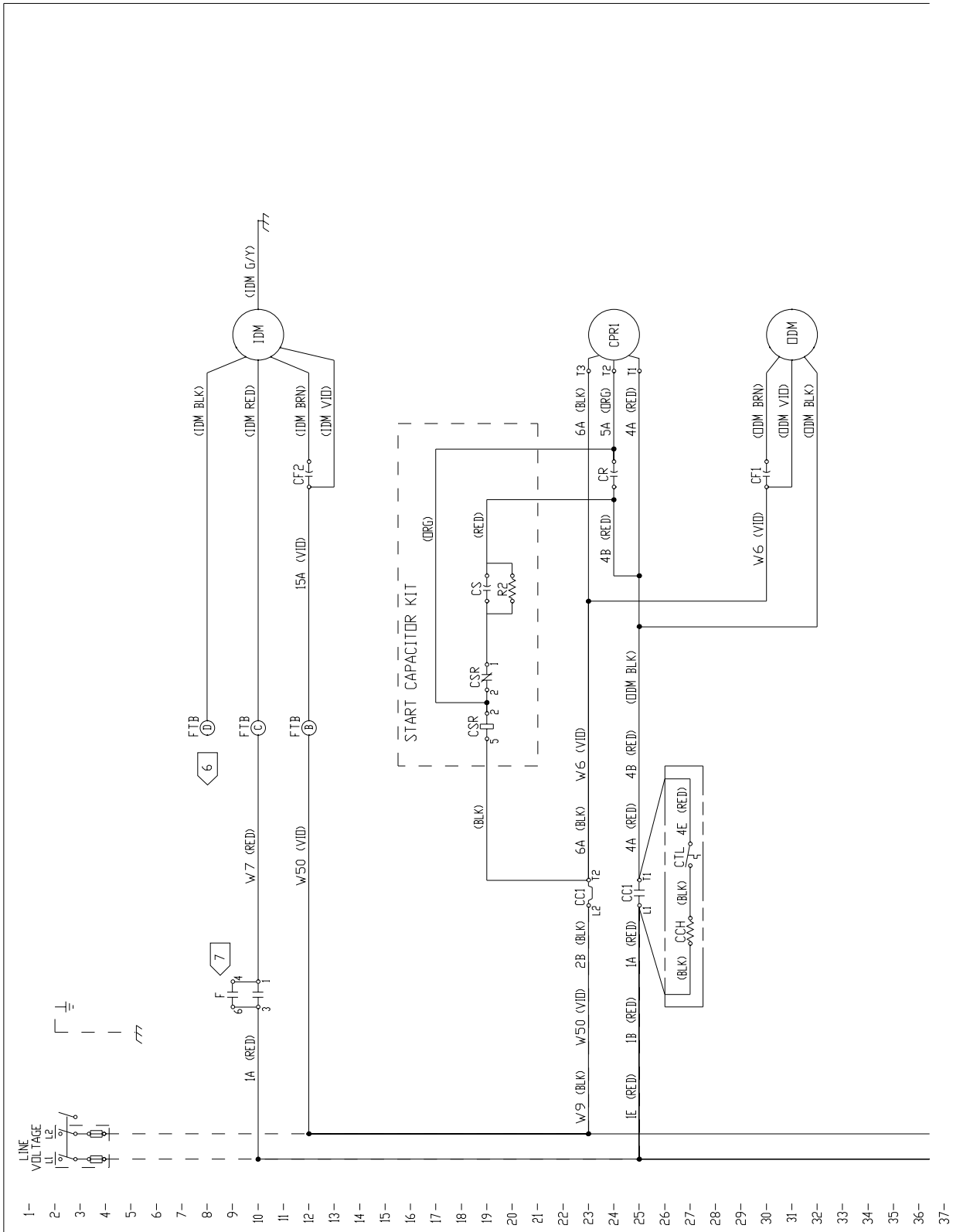
- UNLESS OTHERWISE NOTED, ALL SWITCHES ARE SHOWN AT 25% (77°F) AT ATMOSPHERIC PRESSURE AT 50% RELATIVE HUMIDITY WITH ALL UTILITIES TURNED OFF AND AFTER A NORMAL SHUTDOWN HAS OCCURRED.
- DASHED LINES INDICATE RECOMMENDED FIELD WIRING BY OTHERS. DASHED LINE ENCLOSURES AND/OR DASHED DEVICE OUTLINES INDICATE COMPONENTS PROVIDED BY THE FIELD. PHANTOM LINE ENCLOSURES INDICATE ALTERNATE CIRCUITRY OR AVAILABLE SALES OPTIONS.
- NUMBERS ALONG THE RIGHT SIDE OF THE SCHEMATIC DESIGNATE THE LOCATION OF CONTACTS BY LINE NUMBER. AN UNDERLINED NUMBER INDICATES A NORMALLY CLOSED CONTACT.
- THREE-PHASE MOTORS ARE PROTECTED UNDER PRIMARY SINGLE PHASING CONDITIONS. ALL MOTORS HAVE INTERNAL OVERLOAD PROTECTION AND COMPRESSORS HAVE INTERNAL THERMAL PROTECTION.
- CONNECTIONS SHOWN ARE FOR 230V/60HZ/PH UNITS. WHEN 208V/60HZ/PH OPERATION IS REQUIRED, MOVE WIRE W9 (BLK) FROM THE 230V TERMINAL ON TNS1 TO THE 208V TERMINAL.
- FEATURES SHOWN ARE FOR DUAL-STAGE GAS OPERATION. WHEN SINGLE-STAGE OPERATION IS REQUIRED, WIRE 21A(VID) IS NOT CONNECTED TO IGN, AND WIRE (IND VID) IS NOT CONNECTED TO THE EQUIPMENT.
- CONNECTIONS SHOWN ARE FOR LOW SPEED OPERATION (COOLING) AND HIGH SPEED OPERATION (HEATING). WHEN HIGH SPEED COOLING IS REQUIRED, MOVE WIRE 11A FROM FTB-C TO FTB-D.
- CONNECTIONS SHOWN ARE FOR 3 TON UNITS. FOR 3 TON UNITS (AND BELOW), THERE ARE NO FAN RELAY (F) JUMPERS FROM PIN 3 TO PIN 6 OR FROM PIN 1 TO PIN 4.
- CONNECTIONS SHOWN ARE FOR 4 AND 5 TON UNITS. FOR 3 TON UNITS (AND BELOW), THERE ARE NO HEAT RELAY (H) JUMPERS FROM PIN 1 TO PIN 4, PIN 3 TO PIN 6, OR PIN 2 TO PIN 5.

<p><b>⚠ WARNING</b> HAZARDOUS VOLTAGE! DISCONNECT ALL ELECTRIC POWER, INCLUDING ALL DISCONNECTS, BEFORE SERVICING. FAILURE TO DISCONNECT POWER BEFORE SERVICING CAN CAUSE SEVERE PERSONAL INJURY OR DEATH.</p>	<p><b>⚠ AVERTISSEMENT</b> VOLTAGE HASARDEUX! DECONNECTEZ TOUTES LES SOURCES ELECTRIQUES, Y COMPRIS LES DISCONNECTS, AVANT D'ENTRAÎNER DES REPARATIONS. FAUTE DE DECONNECTER LA SOURCE ELECTRIQUE AVANT D'ENTRAÎNER DES REPARATIONS PEUT CAUSER DES BLESSURES SEVERES OU LA MORT.</p>	<p><b>⚠ CAUTION</b> USE COPPER CONDUCTORS ONLY! UNIT TERMINALS ARE NOT DESIGNED TO ACCEPT OTHER TYPES OF CONDUCTORS. FAILURE TO DO SO MAY CAUSE DAMAGE TO THE EQUIPMENT.</p>
--	--	--

**IMPORTANT!**  
DO NOT ENERGIZE UNIT UNTIL CHECK-OUT AND START-UP PROCEDURE HAS BEEN COMPLETED.

4366-1002 E

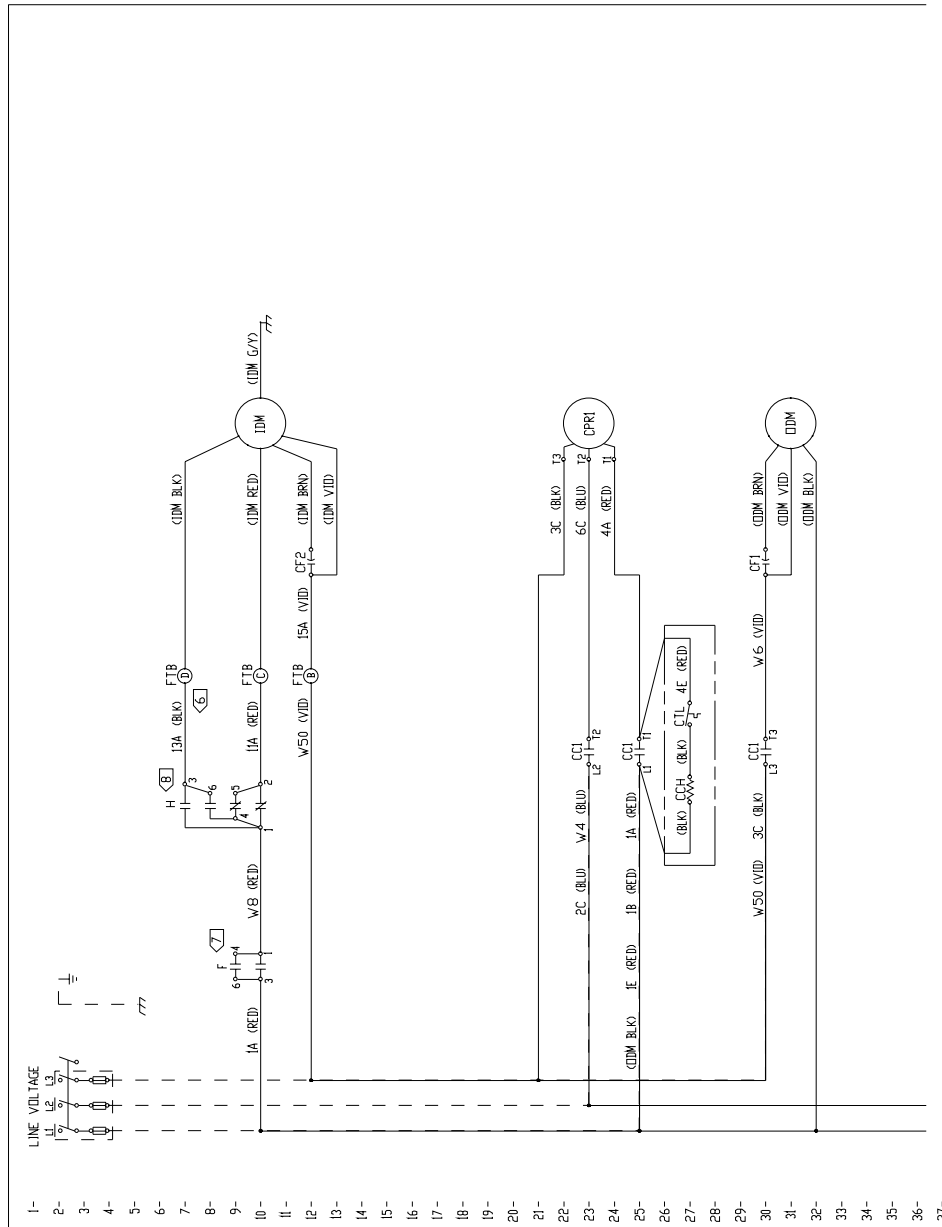
**Diagram 2**  
**Power Schematic - 230v/60hz/1ph**  
**2 - 5 Ton Single Stage Gas Heat / Oversize Drive Motor**  
**4366-1018**

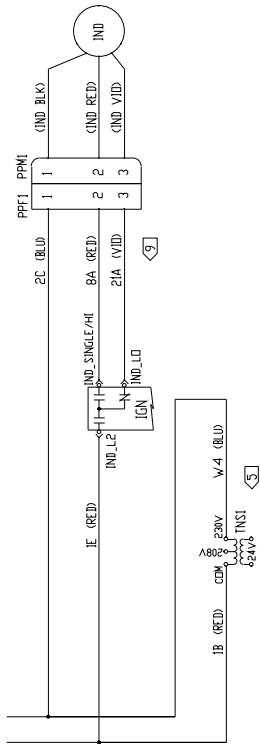






**Diagram 3**  
**Power Schematic - 230v/60hz/3ph**  
**2 - 5 Ton Single Stage Gas Heat / Direct Drive Motor**  
**4366-1000**





REF	DESCRIPTION	LINE
CC1	COMPRESSOR CONTACTOR	23,25,30
CCH	CRANKCASE HEATER	27
CF1	ID MOTOR CAPACITOR	30
CF2	ID MOTOR CAPACITOR	12
CPR1	COMPRESSOR	23
CTL	COIL TEMP LIMIT SWITCH	27
F	FAN RELAY	9,10
FTB	FAN TERMINAL BLOCK	7,10,12
H	HEAT RELAY	7-10
IDM	ID FAN MOTOR	10
IGN	IGNITION MODULE	40
IND	INDUCER MOTOR	40
IDM	ID FAN MOTOR	31
TNS1	LOW VOLTAGE TRANSFORMER	45

COLOR	ABBR	COLOR	ABBR
BLACK	BLK	ORANGE	ORG
BLUE	BLU	RED	RED
BROWN	BRN	VIOLET (PURPLE)	VIO
GRAY (SLATE)	GRA	WHITE	WHT
GREEN/YELLOW	G/Y	YELLOW	YEL

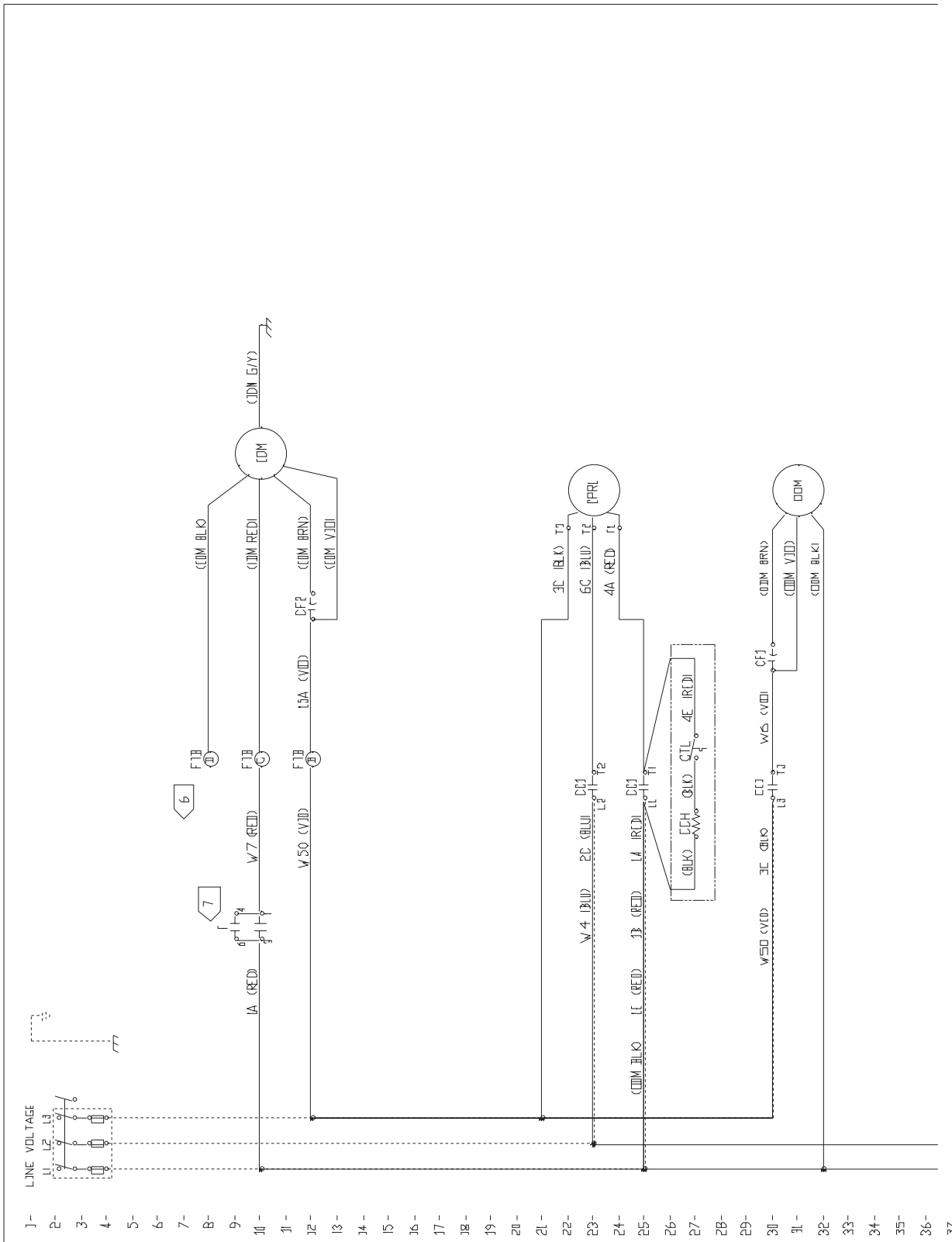
- UNLESS OTHERWISE NOTED, ALL SWITCHES ARE SHOWN AT 25° C (77° F) AT ATMOSPHERIC PRESSURE. AT 50% RELATIVE HUMIDITY WITH ALL UTILITIES TURNED OFF AND AFTER A NORMAL SHUTDOWN HAS OCCURRED.
- DASHED LINES INDICATE RECOMMENDED FIELD WIRING BY OTHERS. DASHED LINE ENCLLOSURES AND/OR DASHED DEVICE OUTLINES INDICATE COMPONENTS PROVIDED BY THE FIELD. PHANTOM LINE ENCLLOSURES INDICATE ALTERNATE CIRCUITRY OR AVAILABLE SALES OPTIONS.
- NUMBERS ALONG THE RIGHT SIDE OF THE SCHEMATIC DESIGNATE THE LOCATION OF CONTACTS BY LINE NUMBER. AN UNDERLINED NUMBER INDICATES A NORMALLY CLOSED CONTACT.
- THREE-PHASE MOTORS ARE PROTECTED UNDER PRIMARY SINGLE PHASING CONDITIONS. ALL PHASES MUST BE PROTECTED UNDER OVERLOAD PROTECTION AND COMPRESSORS HAVE INTERNAL THERMAL PROTECTION.
- CONNECTIONS SHOWN ARE FOR 230V/60HZ/3PH UNITS. WHEN 208V/60HZ/3PH OPERATION IS REQUIRED, MOVE WIRE W4 (BLU) FROM THE 230V TERMINAL ON TNS1 TO THE 208V TERMINAL.
- CONNECTIONS SHOWN ARE FOR LOW SPEED OPERATION (COOLING) AND HIGH SPEED OPERATION (HEATING). WHEN HIGH SPEED COOLING IS REQUIRED, MOVE WIRE 11A FROM FTB-C TO FTB-D.
- CONNECTIONS SHOWN ARE FOR 4 AND 5 TON UNITS. FOR 3 TON UNITS (AND BELOW), THERE ARE NO FAN RELAY (F) JUMPERS FROM PIN 1 TO PIN 4 OR FROM PIN 3 TO PIN 6.
- CONNECTIONS SHOWN ARE FOR 4 AND 5 TON UNITS. FOR 3 TON UNITS (AND BELOW), THERE ARE NO HEAT RELAY (H) JUMPERS FROM PIN 1 TO PIN 4, PIN 3 TO PIN 6, OR PIN 2 TO PIN 5.
- FUTURE CONNECTIONS SHOWN ARE FOR DUAL-STAGE GAS OPERATION. WHEN SINGLE-STAGE OPERATION IS REQUIRED, WIRE 21A (VID) IS NOT CONNECTED TO IGN, AND WIRE (IND) IS NOT PRESENT.

<p><b>⚠ WARNING</b></p> <p>HAZARDOUS VOLTAGE!</p> <p>DISCONNECT ALL ELECTRIC POWER BEFORE SERVICING.</p> <p>FAILURE TO DISCONNECT POWER BEFORE SERVICING CAN CAUSE SEVERE PERSONAL INJURY OR DEATH.</p>	<p><b>⚠ AVERTISSEMENT</b></p> <p>VOLTAGE HASARDEUX!</p> <p>DECONNECTEZ TOUTES LES SOURCES D'ÉLECTRICITÉ AVANT D'INTERVENIR SUR LES CIRCUITS ÉLECTRIQUES AVANT D'ÉFFECTUER L'ENTRETIEN.</p> <p>ÉVITEZ DE PRÉVENIR LA SOURCE D'ÉLECTRICITÉ AVANT D'ÉFFECTUER L'ENTRETIEN PEUT ENTRAINER DES BLESSURES CORPORELLES SEVERES OU LA MORT.</p>	<p><b>⚠ CAUTION</b></p> <p>USE COPPER CONDUCTORS ONLY. UNIT TERMINALS ARE NOT DESIGNED FOR OTHER TYPES OF CONDUCTORS.</p> <p>FAILURE TO DO SO MAY CAUSE DAMAGE TO THE EQUIPMENT.</p>
---	---	--

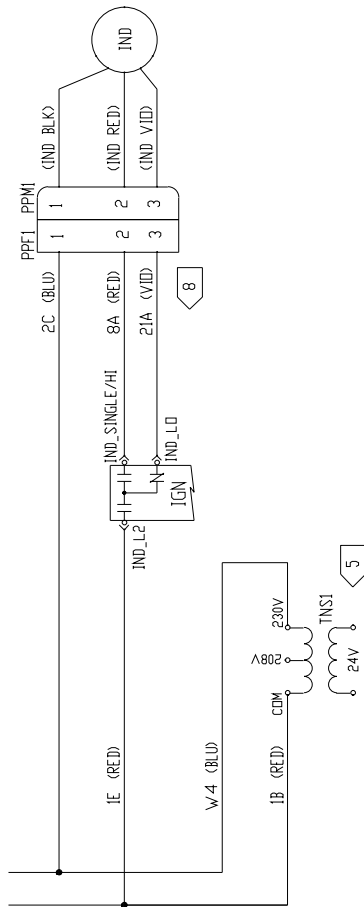
**IMPORTANT!**

DO NOT ENERGIZE UNIT UNTIL ALL REPAIRS AND REWIRING PROCEDURES HAS BEEN COMPLETED.

**Diagram 4**  
**Power Schematic - 230v/60hz/3ph**  
**2 - 5 Ton Single Stage Gas Heat / Oversize Drive Motor**  
**4366-1017**



36—  
37—  
38—  
39—  
40—  
41—  
42—  
43—  
44—  
45—  
46—  
47—  
48—  
49—  
50—  
51—  
52—  
53—  
54—  
55—  
56—  
57—  
58—  
59—  
60—  
61—  
62—  
63—  
64—  
65—  
66—  
67—  
68—  
69—  
70—  
71—  
72—  
73—  
74—



1. UNLESS OTHERWISE NOTED, ALL SWITCHES ARE SHOWN AT 25° C (77° F) AT ATMOSPHERIC PRESSURE, AT 50% RELATIVE HUMIDITY WITH ALL UTILITIES TURNED OFF AND AFTER A NORMAL SHUTDOWN HAS OCCURRED.
2. DASHED LINES INDICATE RECOMMENDED FIELD WIRING BY OTHERS. DASHED LINE ENCLOSURES AND/OR DASHED DEVICE OUTLINES INDICATE COMPONENTS PROVIDED BY THE FIELD. PHANTOM LINE ENCLOSURES INDICATE ALTERNATE CIRCUITRY OR AVAILABLE SALES OPTIONS.
3. NUMBERS ALONG THE RIGHT SIDE OF THE SCHEMATIC DESIGNATE THE LOCATION OF CONTACTS BY LINE NUMBER. AN UNDERLINED NUMBER INDICATES A NORMALLY CLOSED CONTACT.
4. THREE-PHASE MOTORS ARE PROTECTED UNDER PRIMARY SINGLE PHASING CONDITIONS. ALL MOTORS HAVE INTERNAL OVERLOAD PROTECTION AND COMPRESSORS HAVE INTERNAL THERMAL PROTECTION.
5. CONNECTIONS SHOWN ARE FOR 230V/60HZ/3PH UNITS. WHEN 208V/60HZ/3PH OPERATION IS REQUIRED, MOVE WIRE W4 (BLU) FROM THE 230V TERMINAL ON TNS1 TO THE 208V TERMINAL.
6. CONNECTIONS SHOWN ARE FOR LOW SPEED OPERATION WHEN HIGH SPEED OPERATION IS REQUIRED; MOVE WIRE W7 FROM FTB-C TO FTB-D.
7. CONNECTIONS SHOWN ARE FOR 4 AND 5 TON UNITS. FOR 3 TON UNITS (AND BELOW), THERE ARE NO FAN RELAY (F) JUMPERS FROM PIN 3 TO PIN 6 OR FROM PIN 1 TO PIN 4.
8. (FUTURE) CONNECTIONS SHOWN ARE FOR DUAL-STAGE GAS HEAT OPERATION. IF SINGLE-STAGE OPERATION IS REQUIRED, WIRE 21A(VID) IS NOT CONNECTED TO IGN AND WIRE (IND VID) IS NOT PRESENT.

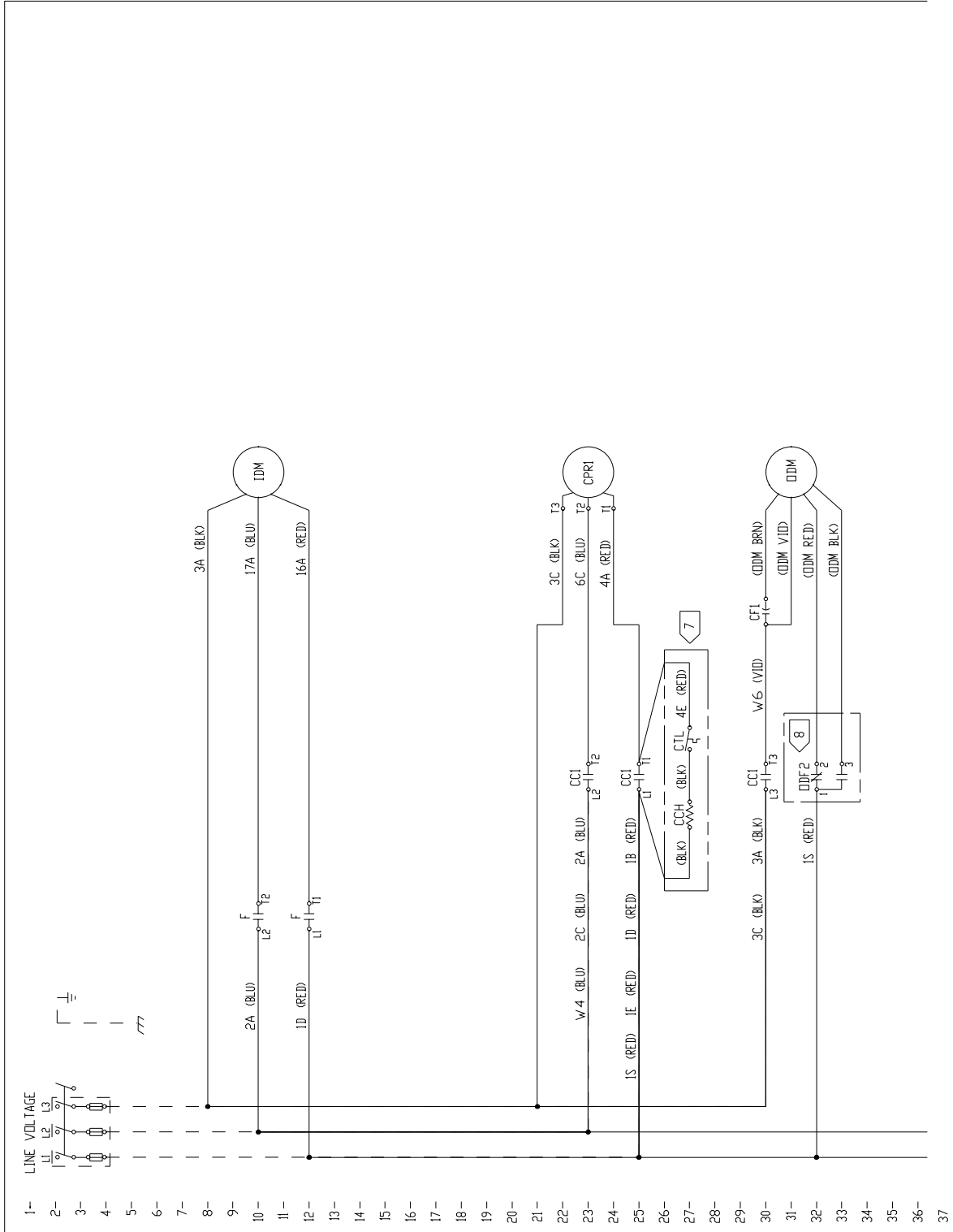
REF	DESCRIPTION	LINE
CC1	COMPRESSOR CONTACTOR	23,25,30
CCH	CRANKCASE HEATER	27
CF1	OD MOTOR CAPACITOR	30
CF2	ID MOTOR CAPACITOR	12
CPRI	COMPRESSOR	23
CTL	COIL TEMP LIMIT SWITCH	27
F	FAN RELAY	9,10
FTB	ID FAN TERMINAL BLOCK	8,10,12
IDM	ID FAN MOTOR	10
IGN	IGNITION MODULE	40,41
IND	INDUCER MOTOR	40
IDM	ID FAN MOTOR	31
TNS1	LOW VOLTAGE TRANSFORMER	45

COLOR	ABBR	COLOR	ABBR
BLACK	BLK	ORANGE	ORG
BLUE	BLU	RED	RED
BROWN	BRN	VIOLET (PURPLE)	VID
GRAY (SLATE)	GRA	WHITE	WHT
GREEN/YELLOW	G/Y	YELLOW	YEL

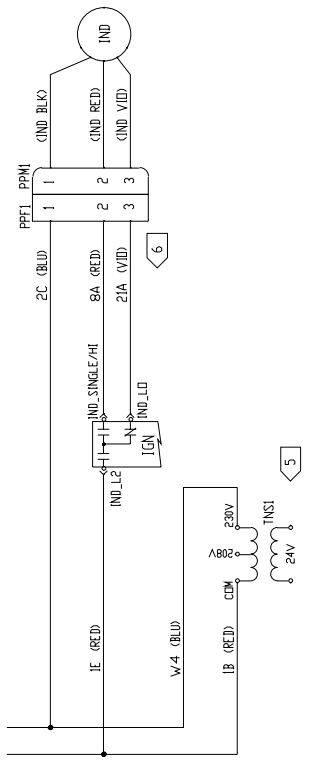
**IMPORTANT!**  
DO NOT ENERGIZE UNIT UNTIL CHECK-OUT AND START-UP PROCEDURE HAS BEEN COMPLETED.

<p><b>WARNING</b></p> <p><b>HAZARDOUS VOLTAGE:</b> DISCONNECT ALL ELECTRIC POWER, INCLUDING PHANTOM DISCONNECTS, BEFORE SERVICING.</p> <p>FAILURE TO DISCONNECT POWER BEFORE SERVICING CAN CAUSE SEVERE PERSONAL INJURY OR DEATH.</p>	<p><b>CAUTION</b></p> <p>USE COPPER CONDUCTORS ONLY! UNIT TERMINALS ARE NOT DESIGNED TO ACCEPT OTHER TYPES OF CONDUCTORS.</p> <p>FAILURE TO DO SO MAY CAUSE DAMAGE TO THE EQUIPMENT.</p>
<p><b>AVERTISSEMENT</b></p> <p><b>VOLTAGE HASARDEUX!</b> DECONNECTEZ TOUTES LES SOURCES ELECTRIQUES INCLUANT LES DISJONCTEURS STAGES A DISTANCE AVANT D'EFFECTUER L'ENTRETIEN.</p> <p>FAUTE DE DECONNECTER LA SOURCE ELECTRIQUE AVANT D'EFFECTUER L'ENTRETIEN PEUT ENTRAINER DES BLESSURES CORPORELLES SEVERES OU LA MORT.</p>	<p><b>IMPORTANT!</b></p> <p>DO NOT ENERGIZE UNIT UNTIL CHECK-OUT AND START-UP PROCEDURE HAS BEEN COMPLETED.</p>

**Diagram 5**  
**Power Schematic - 230v/60hz/3ph**  
**2 - 7.5 Ton Single Stage Gas Heat / Belt Drive Motor**  
**4366-1016**



36-  
37-  
38-  
39-  
40-  
41-  
42-  
43-  
44-  
45-  
46-  
47-  
48-  
49-  
50-  
51-  
52-  
53-  
54-  
55-  
56-  
57-  
58-  
59-  
60-  
61-  
62-  
63-  
64-  
65-  
66-  
67-  
68-  
69-  
70-  
71-  
72-  
73-  
74-  
75-  
76-  
77-  
78-



REF	DESCRIPTION	LINE
CCI	COMPRESSOR CONTACTOR	23,25,30
CCH	CRANKCASE HEATER	27
CPI	OD MOTOR CAPACITOR	30
CPM	COMPRESSOR	23
CTL	COIL TEMP LIMIT SWITCH	27
F	FAN CONTACTOR	10,12
FD	FAN MOTOR	10
IGN	IGNITION MODULE	40,41
IND	INDUCER MOTOR	40
ODF2	OD FAN SPEED RELAY	32,33
ODM	OD FAN MOTOR	31
INS1	LOW VOLTAGE TRANSFORMER	45

COLOR	ABBV	COLOR	ABBV
BLACK	BLK	DRANGE	DRG
BLUE	BLU	RED	RED
BROWN	BRN	VIOLLET (PURPLE)	VID
GRAY (SLATE)	GRN	WHITE	WHT
GREEN/YELLOW	G/Y	YELLOW	YEL

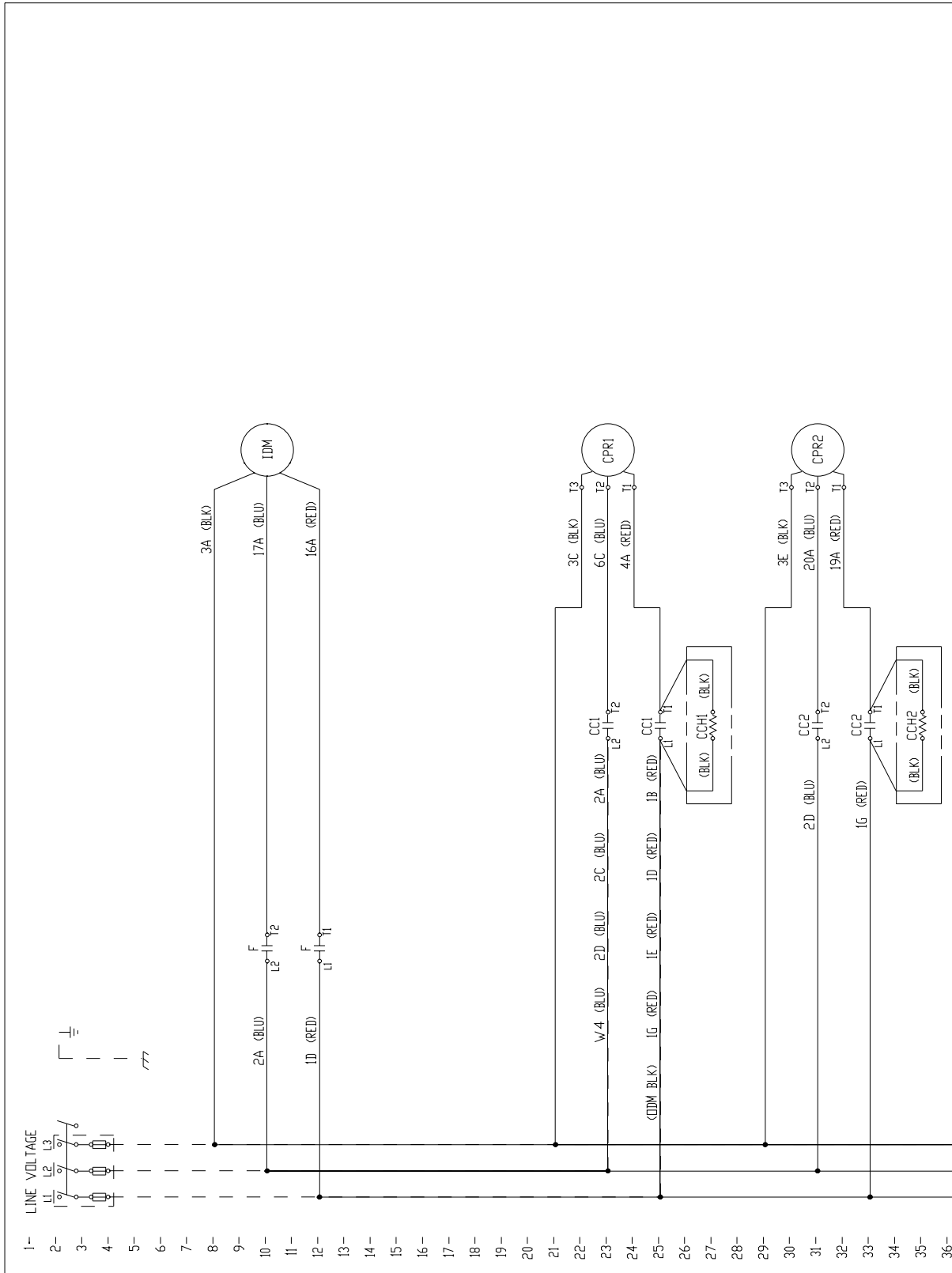
- UNLESS OTHERWISE NOTED, ALL SWITCHES ARE SHOWN AT 25° C (77° F) AT ATMOSPHERIC PRESSURE. AT 50% RELATIVE HUMIDITY WITH ALL UTILITIES TURNED OFF AND AFTER A NORMAL SHUTDOWN HAS OCCURRED.
- DASHED LINES INDICATE RECOMMENDED FIELD WIRING BY OTHERS. DASHED LINE ENDS INDICATE THE FIELD WIRING. SOLID LINES INDICATE THE FIELD WIRING PROVIDED BY THE FIELD. PHANTOM LINE ENDS INDICATE ALTERNATE CIRCUITRY OR AVAILABLE SALES OPTIONS.
- NUMBERS ALONG THE RIGHT SIDE OF THE SCHEMATIC DESIGNATE THE LOCATION OF CONTACTS BY LINE NUMBER. AN UNDERLINED NUMBER INDICATES A NORMALLY CLOSED CONTACT.
- THREE-PHASE MOTORS ARE PROTECTED UNDER PRIMARY SINGLE PHASING CONDITIONS. ALL MOTORS HAVE INTERNAL OVERLOAD PROTECTION AND COMPRESSORS HAVE INTERNAL THERMAL PROTECTION.
- CONNECTIONS SHOWN ARE FOR 230V/60HZ/3PH UNITS. WHEN 208V/60HZ/3PH OPERATION IS REQUIRED, MOVE WIRE W4 (BLU) FROM THE 230V TERMINAL ON INS1 TO THE 208V TERMINAL.
- CONNECTIONS SHOWN ARE FOR DUAL-STAGE GAS OPERATION. WHEN SINGLE-STAGE OPERATION IS REQUIRED, WIRE 21A (VID) IS NOT CONNECTED TO IGN, AND WIRE (CIND Y/VD) IS NOT PRESENT.
- CONNECTIONS SHOWN ARE FOR 5-TON AND SMALLER UNITS. FOR UNITS GREATER THAN 5-TON, CTL AND WIRE 4E (CRD) ARE NOT PRESENT, AND CCH WIRE IS CONNECTED TO CCI-L1 AND CCI-T1.
- CONNECTIONS SHOWN ARE FOR DEHUMIDIFICATION OPTION (2-SPEED ODM). FOR 1-SPEED ODM, WIRES 1S (RED), ODM Y (RED) AND COMPONENT ODF2 ARE NOT PRESENT AND (ODM BLK) IS CONNECTED TO CCI-L1.

**⚠ WARNING**  
HAZARDOUS VOLTAGE!  
DISCONNECT ALL ELECTRIC POWER, INCLUDING REMOTE DISCONNECTS, BEFORE SERVICING.  
FAILURE TO DISCONNECT POWER BEFORE SERVICING WILL CAUSE SEVERE PERSONAL INJURY OR DEATH.

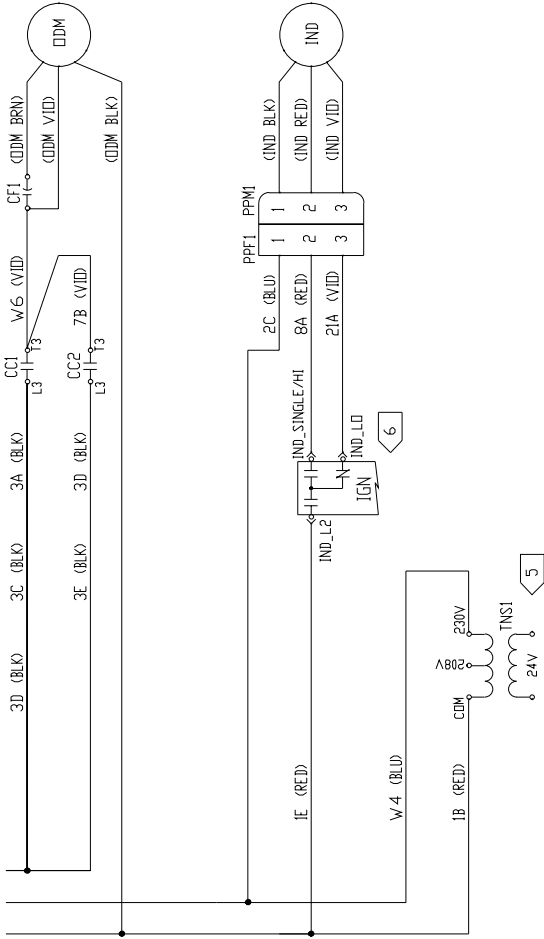
**⚠ AVERTISSEMENT**  
VOLTAGE HASARDEUX!  
DECONNECTEZ TOUTES LES SOURCES ELECTRIQUES INCLUANT LES DISJONCTEURS SITUES A DISTANCE AVANT D'EFFECTUER L'ENTRETIEN.  
FAUTE DE DECONNECTER LA SOURCE ELECTRIQUE AVANT D'EFFECTUER L'ENTRETIEN PEUT ENTRAINER DES BLESSURES CORPORELLES SEVERES OU LA MORT.

**⚠ IMPORTANT!**  
DO NOT ENERGIZE UNIT UNTIL CHECK-OUT AND START-UP PROCEDURE HAS BEEN COMPLETED.

**Diagram 6**  
**Power Schematic - 230v/60hz/3ph**  
**7.5 - 10 Ton Gas Heat / Dual Compressor**  
**4366-1033**







REF	DESCRIPTION	LINE
CCI	COMPRESSOR CONTACTOR 1	23,25,37
CC2	COMPRESSOR CONTACTOR 2	31,33,39
CCH1	CRANKCASE HEATER 1	27
CCH2	CRANKCASE HEATER 2	35
CF1	DD FAN CAPACITOR	37
CPR1	COMPRESSOR 1	23
CPR2	COMPRESSOR 2	31
F	FAN CONTACTOR	10,12
FAN	FAN MOTOR	10
IGN	IGNITION MODULE	46,47
IND	INDUCER MOTOR	46
DDM	DD FAN MOTOR	38
TNS1	LOW VOLTAGE TRANSFORMER	51

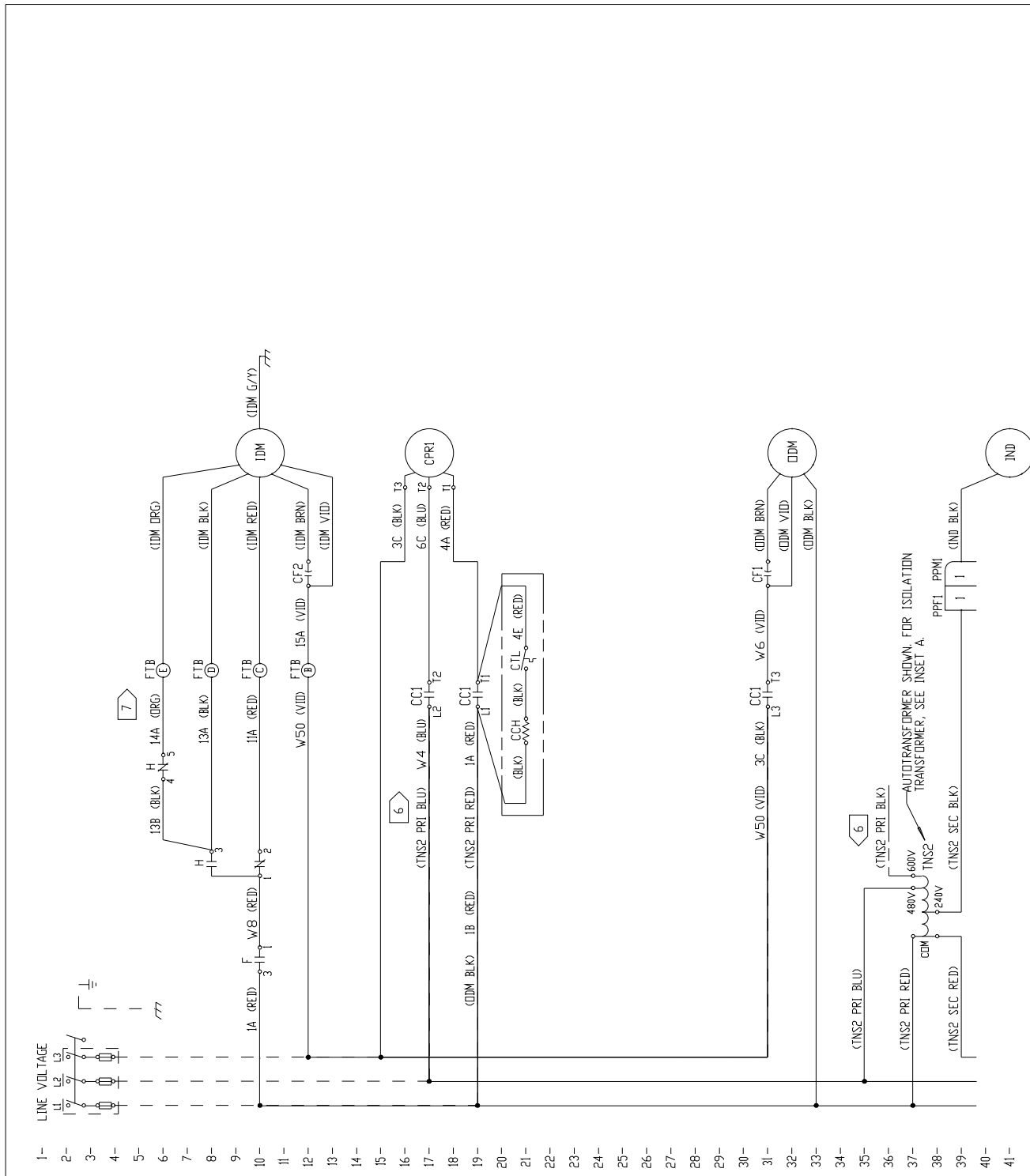
COLOR	ABBR	COLOR	ABBR
BLACK	BLK	ORANGE	DRG
BLUE	BLU	RED	RED
BROWN	BRN	VIOLET (PURPLE)	VIO
GRAY (SLATE)	GRA	WHITE	WHT
GREEN/YELLOW	G/Y	YELLOW	YEL

- UNLESS OTHERWISE NOTED, ALL SWITCHES ARE SHOWN AT 25° C (77° F) AT ATMOSPHERIC PRESSURE, AT 50% RELATIVE HUMIDITY WITH ALL UTILITIES TURNED OFF AND AFTER A NORMAL SHUTDOWN HAS OCCURRED.
  - DASHED LINES INDICATE RECOMMENDED FIELD WIRING BY OTHERS. DASHED LINE ENCLOSURES AND/OR DASHED DEVICE OUTLINES INDICATE COMPONENTS PROVIDED BY THE FIELD. PHANTOM LINE ENCLOSURES INDICATE ALTERNATE CIRCUITRY OR AVAILABLE SALES OPTIONS.
  - NUMBERS ALONG THE RIGHT SIDE OF THE SCHEMATIC DESIGNATE THE LOCATION OF CONTACTS BY LINE NUMBER. AN UNDERLINED NUMBER INDICATES A NORMALLY CLOSED CONTACT.
  - THREE-PHASE MOTORS ARE PROTECTED UNDER PRIMARY SINGLE-PHASING CONDITIONS. ALL MOTORS HAVE INTERNAL OVERLOAD PROTECTION AND COMPRESSORS HAVE INTERNAL THERMAL PROTECTION.
- 5 CONNECTIONS SHOWN ARE FOR 230V/60HZ/3PH UNITS. WHEN 208V/60HZ/3PH OPERATION IS REQUIRED, MOVE WIRE W4 (BLU) FROM THE 230V TERMINAL ON TNS1 TO THE 208V TERMINAL.
- 6 CONNECTIONS SHOWN ARE FOR DUAL-STAGE GAS OPERATION. WHEN SINGLE-STAGE OPERATION IS REQUIRED, WIRE 21A (VID) IS NOT CONNECTED TO IGN, AND WIRE (IND VID) IS NOT PRESENT.

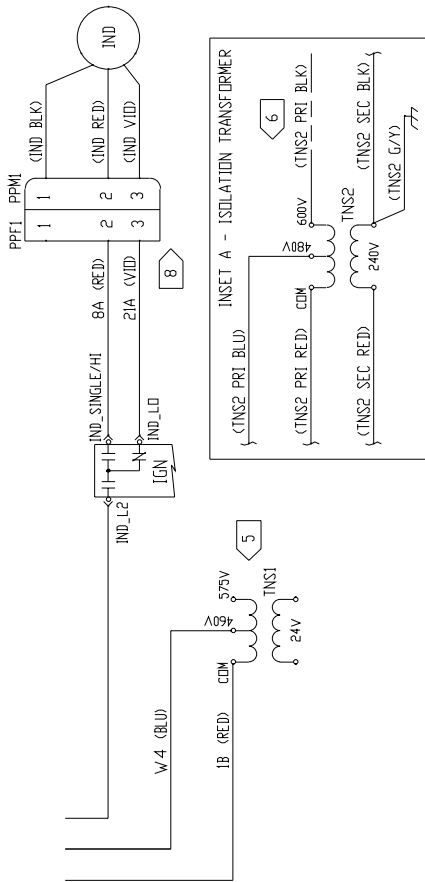
**IMPORTANT!**  
DO NOT ENERGIZE UNIT UNTIL CHECK-OUT AND START-UP PROCEDURE HAS BEEN COMPLETED.

⚠ WARNING	⚠ AVERTISSEMENT	⚠ CAUTION
HAZARDOUS VOLTAGE! DISCONNECT ALL ELECTRIC POWER, INCLUDING REMOTE DISCONNECTS, BEFORE SERVICING. FAILURE TO DISCONNECT POWER BEFORE SERVICING CAN CAUSE SEVERE PERSONAL INJURY OR DEATH.	VOLTAGE HASARDEUX! DECONNECTEZ TOUTES LES SOURCES ELECTRIQUES, Y COMPRIS LES DISJONCTEURS A DISTANCE AVANT D'ENTRETIEN. FAUTE DE DECONNECTER LA SOURCE ELECTRIQUE AVANT D'ENTRETIEN PEUT ENTRAINER DES BLESSURES CORPORELLES SEVERES OU LA MORT.	USE COPPER CONDUCTORS ONLY! UNIT TERMINALS ARE NOT DESIGNED TO ACCEPT OTHER TYPES OF CONDUCTORS. FAILURE TO DO SO MAY CAUSE DAMAGE TO THE EQUIPMENT.

**Diagram 7**  
**Power Schematic - 460-575v/60hz/3ph**  
**2 - 3 Ton Single Stage Gas Heat / Direct**  
**Drive Motor**  
**4366-1004**



39-  
40-  
41-  
42-  
43-  
44-  
45-  
46-  
47-  
48-  
49-  
50-  
51-  
52-  
53-  
54-  
55-  
56-  
57-  
58-  
59-  
60-  
61-  
62-  
63-  
64-  
65-  
66-  
67-  
68-  
69-  
70-  
71-  
72-  
73-  
74-  
75-  
76-  
77-  
78-



1. UNLESS OTHERWISE NOTED, ALL SWITCHES ARE SHOWN AT 25°C (77°F), AT ATMOSPHERIC PRESSURE, AT 50% RELATIVE HUMIDITY WITH ALL UTILITIES TURNED OFF AND AFTER A NORMAL SHUTDOWN HAS OCCURRED.
2. DASHED LINES INDICATE RECOMMENDED FIELD WIRING BY OTHERS. DASHED LINE ENCLOSURES AND/OR DASHED DEVICE OUTLINES INDICATE COMPONENTS PROVIDED BY THE FIELD. PHANTOM LINE ENCLOSURES INDICATE ALTERNATE CIRCUITRY OR AVAILABLE SALES OPTIONS.
3. NUMBERS ALONG THE RIGHT SIDE OF THE SCHEMATIC DESIGNATE THE LOCATION OF CONTACTS BY LINE NUMBER. AN UNDERLINED NUMBER INDICATES A NORMALLY CLOSED CONTACT.
4. THREE-PHASE MOTORS ARE PROTECTED UNDER PRIMARY SINGLE PHASING CONDITIONS. ALL MOTORS HAVE INTERNAL OVERLOAD PROTECTION AND COMPRESSORS HAVE INTERNAL THERMAL PROTECTION.
5. CONNECTIONS SHOWN ARE FOR 460V/60HZ/3PH UNITS. WHEN 575V/60HZ/3PH OPERATION IS REQUIRED, MOVE WIRE W4(BLU) FROM THE 460V TERMINAL ON TNS1 TO THE 575V TERMINAL.
6. CONNECTIONS SHOWN ARE FOR 460V/60HZ/3PH UNITS. WHEN 575V/60HZ/3PH OPERATION IS REQUIRED, REMOVE WIRE (TNS2 PRI. BLU) FROM CCI-L2 AND CONNECT WIRE (TNS2 PRI. BLK) TO CCI-L2.
7. CONNECTIONS SHOWN ARE FOR LOW SPEED OPERATION (COOLING) AND HIGH SPEED OPERATION (HEATING). WHEN HIGH SPEED COOLING IS REQUIRED, REMOVE WIRE 14A(ORG) FROM FTB-E AND TAPE, AND MOVE WIRE 14A(RED) FROM FTB-C TO FTB-D.
8. (FUTURE) CONNECTIONS SHOWN ARE FOR DUAL-STAGE GAS HEAT OPERATION. WHEN SINGLE-STAGE OPERATION IS REQUIRED, WIRE 21A(KVD) IS NOT CONNECTED TO IGN AND WIRE (IND VID) IS NOT PRESENT.

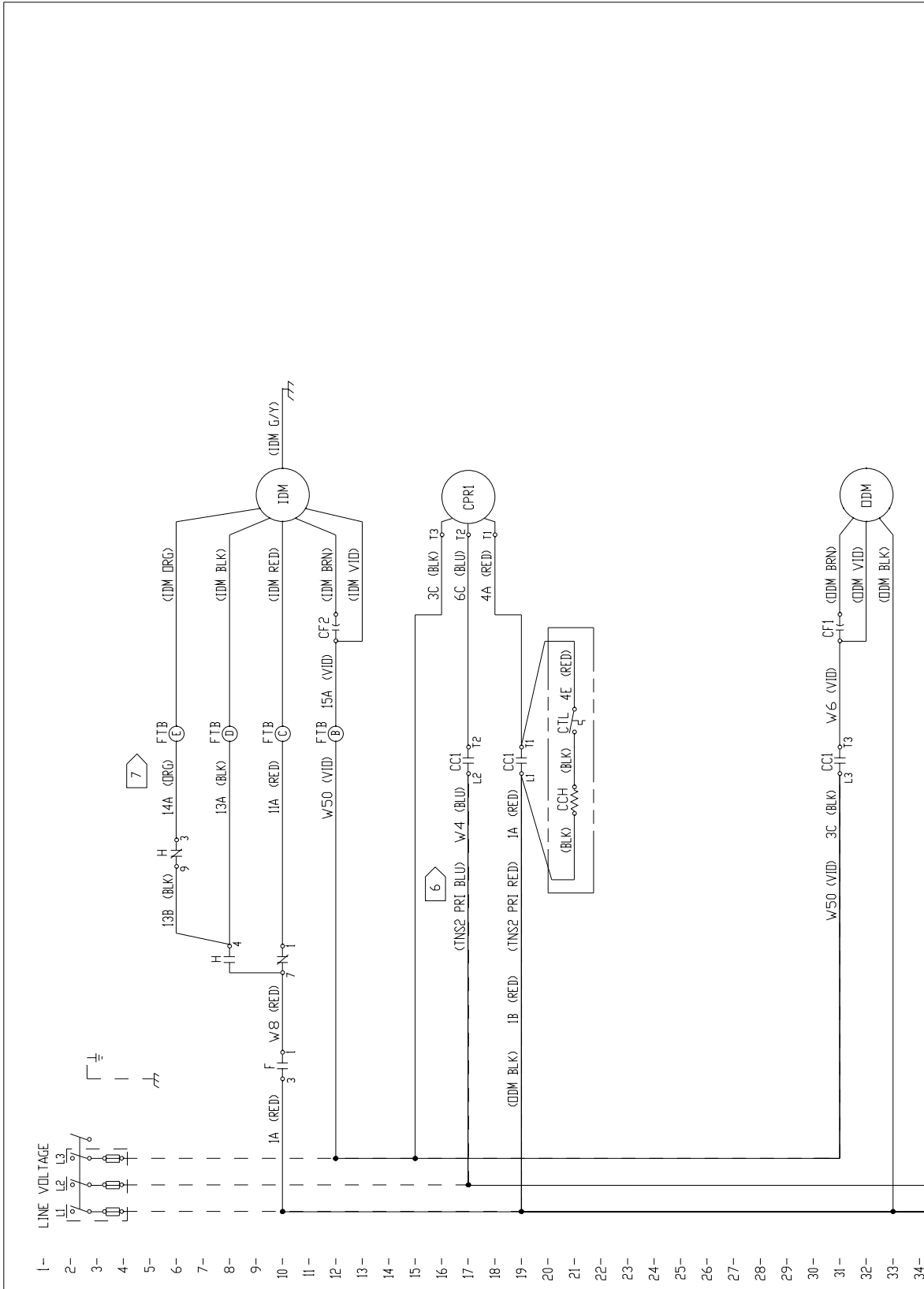
REF	DESCRIPTION	LINE
CCI	COMPRESSOR CONTACTOR	17-19-31
CCH	CRANKCASE HEATER	21
CF1	OD MOTOR CAPACITOR	31
CF2	ID MOTOR CAPACITOR	12
CPRI	COMPRESSOR	17
CTL	COIL TEMP LIMIT SWITCH	21
F	FAN RELAY	10
FTB	FAN TERMINAL BLOCK	6-12
H	HEAT RELAY	6-10
IDM	ID FAN MOTOR	10
IGN	IGNITION MODULE	41-42
IND	INDUCER MOTOR	41
ODM	OD FAN MOTOR	32
TNS1	LOW VOLTAGE TRANSFORMER	45-47
TNS2	INDUCER AUTOTRANSFORMER	37-38

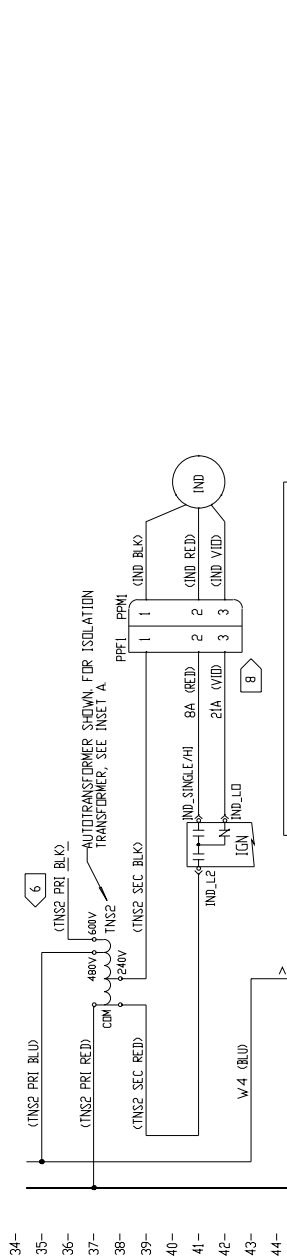
COLOR	ABBR	COLOR	ABBR
BLACK	BLK	ORANGE	DRG
BLUE	BLU	RED	RED
BROWN	BRN	VIOLET (PURPLE)	VIO
GRAY (SLATE)	GRA	WHITE	WHT
GREEN/YELLOW	G/Y	YELLOW	YEL

**IMPORTANT!**  
DO NOT ENERGIZE UNIT UNTIL CHECK-OUT AND START-UP PROCEDURE HAS BEEN COMPLETED.

<p><b>WARNING</b></p> <p>HAZARDOUS VOLTAGE! DISCONNECT ALL ELECTRIC POWER, INCLUDING REMOTE DISCONNECTS, BEFORE SERVICING. FAILURE TO DISCONNECT POWER BEFORE SERVICING CAN CAUSE SEVERE PERSONAL INJURY OR DEATH.</p>	<p><b>CAUTION</b></p> <p>USE COPPER CONDUCTORS ONLY! UNIT TERMINALS ARE NOT DESIGNED TO ACCEPT OTHER TYPES OF CONDUCTORS. FAILURE TO DO SO MAY CAUSE DAMAGE TO THE EQUIPMENT.</p>
<p><b>AVERTISSEMENT</b></p> <p>VOLTAGE HASARDEUX! DECONNECTEZ TOUTES LES SOURCES ELECTRIQUES, Y COMPRIS LES DISJONCTEURS SITUES A DISTANCE AVANT D'EFFECTUER L'ENTRETIEN. FAUTE DE DECONNECTER LA SOURCE ELECTRIQUE AVANT D'EFFECTUER L'ENTRETIEN PEUT ENTRAÎNER DES BLESSURES CORPORELLES SEVERES OU LA MORT.</p>	

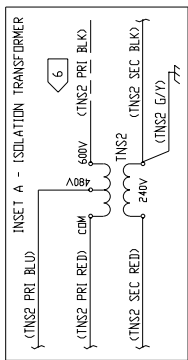
**Diagram 8**  
**Power Schematic - 460-575v/60hz/3ph**  
**4 - 5 Ton Single Stage Gas Heat / Direct**  
**Drive Motor**  
**4366-1032**





REF	DESCRIPTION	LINE
CCI	COMPRESSOR CONTACTOR	17/39/31
CCH	CRANKCASE HEATER	21
CF1	ID MOTOR CAPACITOR	31
CF2	ID MOTOR CAPACITOR	12
CPRI	COMPRESSOR	17
CTL	COIL TEMP LIMIT SWITCH	21
F	FAN RELAY	10
FTB	FAN TERMINAL BLOCK	6-12
H	HEAT RELAY	6-10
IDM	ID FAN MOTOR	10
IGN	IGNITION MODULE	41-42
IND	INDUCER BLOWER	41
IDM	ID FAN MOTOR	32
TNS1	LOW VOLTAGE TRANSFORMER	45-47
TNS2	INDUCER AUTOTRANSFORMER	37-38

COLOR	ABBR	COLOR	ABBR
BLACK	BLK	ORANGE	ORNG
BLUE	BLU	RED	RED
BROWN	BRN	VIOLET (PURPLE)	VIO
GRAT (GLATE)	GRA	WHITE	WHT
GREEN/YELLOW	GY	YELLOW	YEL

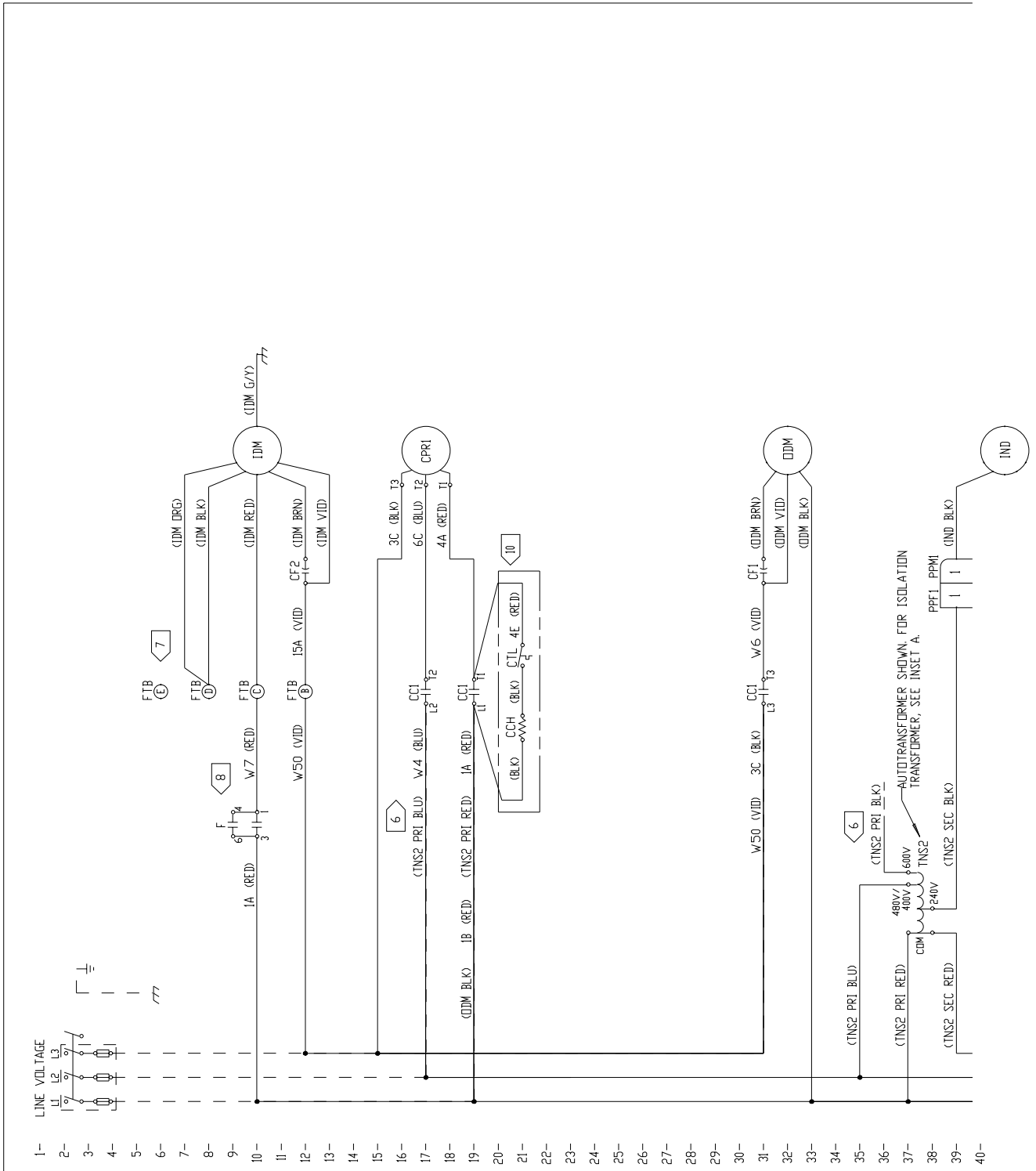


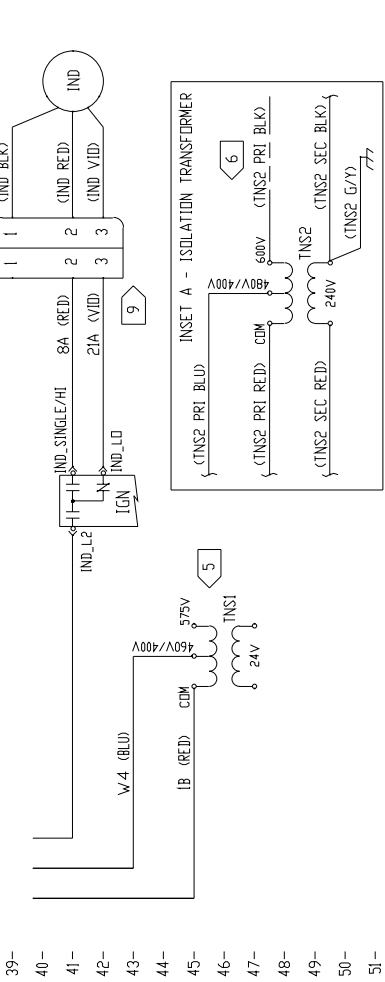
- UNLESS OTHERWISE NOTED, ALL SWITCHES ARE SHOWN AT 25°C (77°F). AT ATMOSPHERIC PRESSURE, AT 50% RELATIVE HUMIDITY WITH ALL UTILITIES TURNED OFF AND AFTER A NORMAL SHUTDOWN HAS OCCURRED.
- DASHED LINES INDICATE RECOMMENDED FIELD WIRING BY OTHERS. DASHED LINE ENCLOSURES AND/OR DASHED DEVICE OUTLINES INDICATE COMPONENTS PROVIDED BY THE FIELD. PHANTOM LINE ENCLOSURES INDICATE ALTERNATE CIRCUITRY OR AVAILABLE SALES OPTIONS.
- NUMBERS ALONG THE RIGHT SIDE OF THE SCHEMATIC DESIGNATE THE LOCATION OF CONTACTS BY LINE NUMBER. AN UNDERLINED NUMBER INDICATES A NORMALLY CLOSED CONTACT.
- THREE-PHASE MOTORS ARE PROTECTED UNDER PRIMARY SINGLE PHASING CONDITIONS. ALL MOTORS HAVE INTERNAL OVERLOAD PROTECTION AND COMPRESSORS HAVE INTERNAL THERMAL PROTECTION.
- CONNECTIONS SHOWN ARE FOR 460V/60HZ/3PH UNITS. WHEN 575V/60HZ/3PH OPERATION IS REQUIRED, MOVE WIRE W4(RED) FROM THE 460V TERMINAL ON TNS1 TO THE 575V TERMINAL.
- CONNECTIONS SHOWN ARE FOR 460V/60HZ/3PH UNITS. WHEN 575V/60HZ/3PH OPERATION IS REQUIRED, REMOVE WIRE (TNS2 PRI BLU) FROM CCI-L2 AND CONNECT WIRE (TNS2 PRI BLK) TO CCI-L2.
- CONNECTIONS SHOWN ARE FOR LOW SPEED OPERATION (COOLING) AND HIGH SPEED OPERATION (HEATING). WHEN HIGH SPEED COOLING IS REQUIRED, REMOVE WIRE 14A(ORNG) FROM FTB-E AND TAPE, AND MOVE WIRE 14A(RED) FROM FTB-C TO FTB-D.
- (FUTURE) CONNECTIONS SHOWN ARE FOR DUAL-STAGE GAS HEAT OPERATION WHEN SINGLE-STAGE OPERATION IS REQUIRED, WIRE 21A(VIO) IS NOT CONNECTED TO IGN AND WIRE (IND VID) IS NOT PRESENT.

⚠ WARNING	⚠ AVERTISSEMENT	⚠ CAUTION
HAZARDOUS VOLTAGE! DISCONNECT ALL ELECTRIC POWER, INCLUDING REMOTE DISCONNECTS, BEFORE SERVICING.	VOLTAGE HAZARDEUX! DÉCONNECTEZ TOUTES LES SOURCES ÉLECTRIQUES, Y COMPRIS LES DISJONCTEURS À DISTANCE AVANT D'EFFECTUER L'ENTRETIEN.	USE COPPER CONDUCTORS ONLY! UNIT TERMINALS ARE NOT DESIGNED TO ACCEPT OTHER TYPES OF CONDUCTORS.
FAILURE TO DISCONNECT POWER BEFORE SERVICING CAN CAUSE SEVERE PERSONAL INJURY OR DEATH.	FAUTE DE DÉCONNECTEZ LA SOURCE ÉLECTRIQUE AVANT D'EFFECTUER LES RÉPARATIONS PEUT CAUSER DES BLESSURES GRAVES OU LA MORT.	FAILURE TO DO SO MAY CAUSE DAMAGE TO THE EQUIPMENT.

**IMPORTANT!**  
DO NOT ENERGIZE UNIT UNTIL CHECK-OUT AND START-UP PROCEDURE HAS BEEN COMPLETED.

**Diagram 9**  
**Power Schematic - 460-575v/60hz/3ph**  
**4 - 5 Ton Single Stage Gas Heat / Oversize**  
**Drive Motor**  
**4366-1011**





- 39—
- 40—
- 41—
- 42—
- 43—
- 44—
- 45—
- 46—
- 47—
- 48—
- 49—
- 50—
- 51—
- 52—
- 53—
- 54—
- 55—
- 56—
- 57—
- 58—
- 59—
- 60—
- 61—
- 62—
- 63—
- 64—
- 65—
- 66—
- 67—
- 68—
- 69—
- 70—
- 71—
- 72—
- 73—
- 74—
- 75—
- 76—
- 77—
- 78—

1. UNLESS OTHERWISE NOTED, ALL SWITCHES ARE SHOWN AT 25°C (77°F). AT ATMOSPHERIC PRESSURE, AT 50% RELATIVE HUMIDITY WITH ALL UTILITIES TURNED OFF AND AFTER A NORMAL SHUTDOWN HAS OCCURRED.
2. DASHED LINES INDICATE RECOMMENDED FIELD WIRING BY OTHERS. DASHED LINE ENCLOSURES AND/OR DASHED DEVICE OUTLINES INDICATE COMPONENTS PROVIDED BY THE FIELD. PHANTOM LINE ENCLOSURES INDICATE ALTERNATE CIRCUITRY OR AVAILABLE SALES OPTIONS.
3. NUMBERS ALONG THE RIGHT SIDE OF THE SCHEMATIC DESIGNATE THE LOCATION OF CONTACTS BY LINE NUMBER. AN UNDERLINED NUMBER INDICATES A NORMALLY CLOSED CONTACT.
4. THREE-PHASE MOTORS ARE PROTECTED UNDER PRIMARY PHASING CONDITIONS. ALL MOTORS HAVE INTERNAL OVERLOAD PROTECTION AND COMPRESSORS HAVE INTERNAL PROTECTION.
- 5 CONNECTIONS SHOWN ARE FOR 380V/60HZ/3PH AND 460V/60HZ/3PH UNITS. WHEN 575V/60HZ/3PH OPERATION IS REQUIRED, MOVE WIRE W4(BLU) FROM THE 460V TERMINAL ON TNS1 TO THE 575V TERMINAL.
- 6 CONNECTIONS SHOWN ARE FOR 380V/60HZ/3PH AND 460V/60HZ/3PH UNITS. WHEN 575V/60HZ/3PH OPERATION IS REQUIRED, REMOVE WIRE (TNS2 PRI. BLU) FROM CCI-L2 AND CONNECT WIRE (TNS2 PRI. BLK) TO CCI-L2.
- 7 CONNECTIONS SHOWN ARE FOR LOW SPEED OPERATION. WHEN HIGH SPEED OPERATION IS REQUIRED, MOVE WIRE (IDM DRG) FROM FTB-D TO FTB-E AND MOVE WIRE W7(RED) FROM FTB-C TO FTB-D.
- 8 CONNECTIONS SHOWN ARE FOR 4 AND 5 TON UNITS. FOR 3 TON UNITS (AND BELOW) THERE ARE NO FAN RELAY (F) JUMPERS FROM PIN 3 TO PIN 6 OR FROM PIN 1 TO PIN 4.
- 9 (FUTURE) CONNECTIONS SHOWN ARE FOR DUAL-STAGE GAS HEAT OPERATION. IF SINGLE-STAGE OPERATION IS REQUIRED, WIRE 2(A)(VID) IS NOT CONNECTED TO IGN AND WIRE (IND VID) IS NOT PRESENT.
- 10 CONNECTIONS SHOWN ARE FOR 460V/60HZ/3PH AND 575V/60HZ/3PH UNITS. FOR 380V/60HZ/3PH UNITS, CCH, CTL, AND WIRE 4(ECD) ARE NOT PRESENT.

<p><b>⚠ WARNING</b></p> <p><b>HAZARDOUS VOLTAGE!</b></p> <p>DISCONNECT ALL ELECTRIC POWER, INCLUDING REMOTE DISCONNECTS, BEFORE SERVICING.</p> <p>FAILURE TO DISCONNECT POWER BEFORE SERVICING CAN CAUSE SEVERE PERSONAL INJURY OR DEATH.</p>	<p><b>⚠ CAUTION</b></p> <p>USE COPPER CONDUCTORS ONLY! UNIT TERMINALS ARE NOT DESIGNED TO ACCEPT OTHER TYPES OF CONDUCTORS.</p> <p>FAILURE TO DO SO MAY CAUSE DAMAGE TO THE EQUIPMENT.</p>
---	--

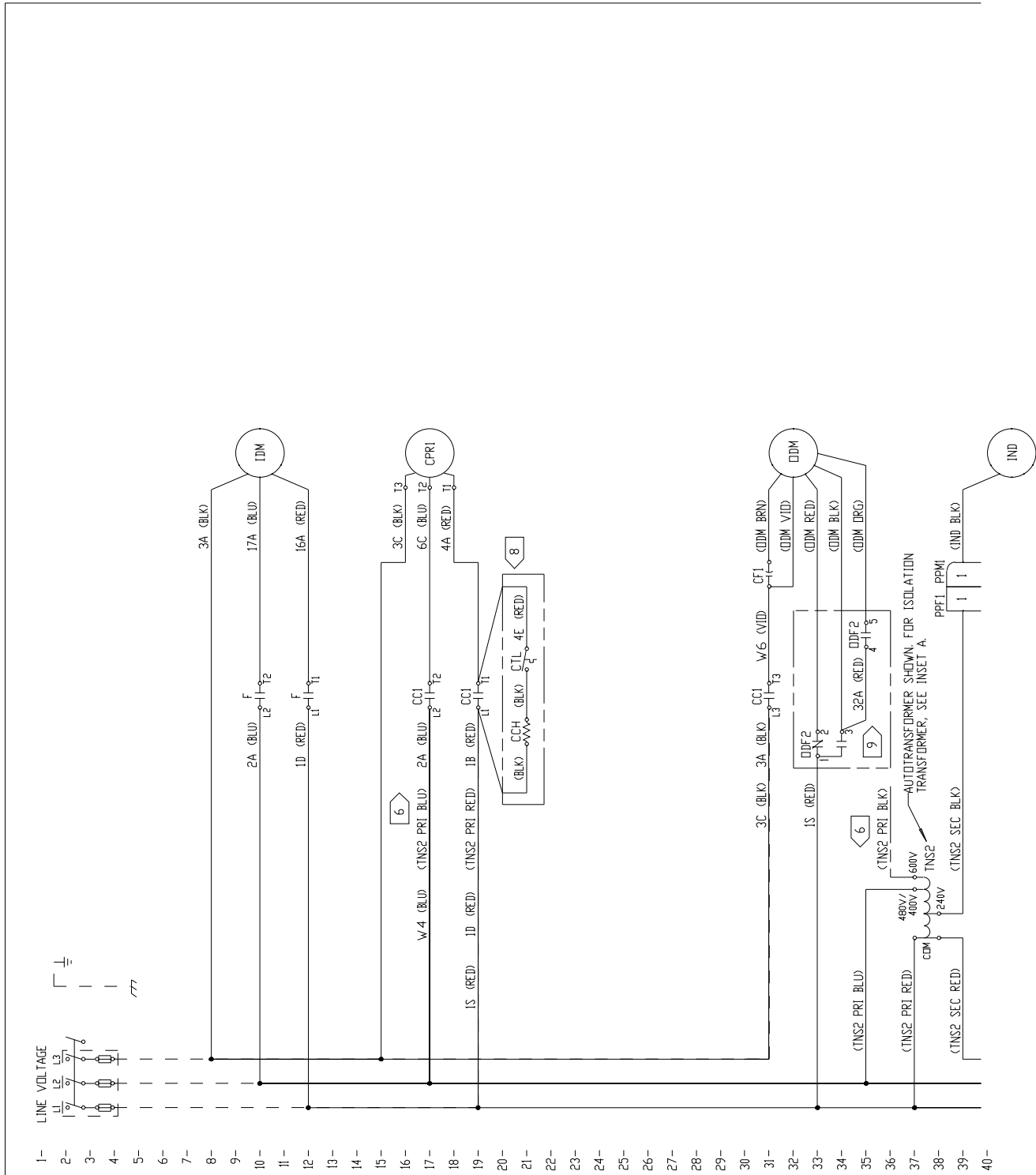
REF	DESCRIPTION	LINE
CCI	COMPRESSOR CONTACTOR	17/19/31
CCH	CRANKCASE HEATER	21
CF1	ID MOTOR CAPACITOR	31
CF2	ID MOTOR CAPACITOR	12
CPRI	COMPRESSOR	17
CTL	COIL TEMP LIMIT SWITCH	21
F	FAN RELAY	9-10
FTB	ID FAN TERMINAL BLOCK	6-12
IDM	ID FAN MOTOR	10
IGN	IGNITION MODULE	41-42
IND	INDUCER MOTOR	41
IDM	ID FAN MOTOR	32
TNS1	LOW VOLTAGE TRANSFORMER	45-47
TNS2	INDUCER AUTOTRANSFORMER	37-38

COLOR	ABBR	COLOR	ABBR
BLACK	BLK	ORANGE	DRG
BLUE	BLU	RED	RED
BROWN	BRN	VIOLET (PURPLE)	VID
GRAY (SLATE)	GRA	WHITE	WHT
GREEN/YELLOW	G/Y	YELLOW	YEL

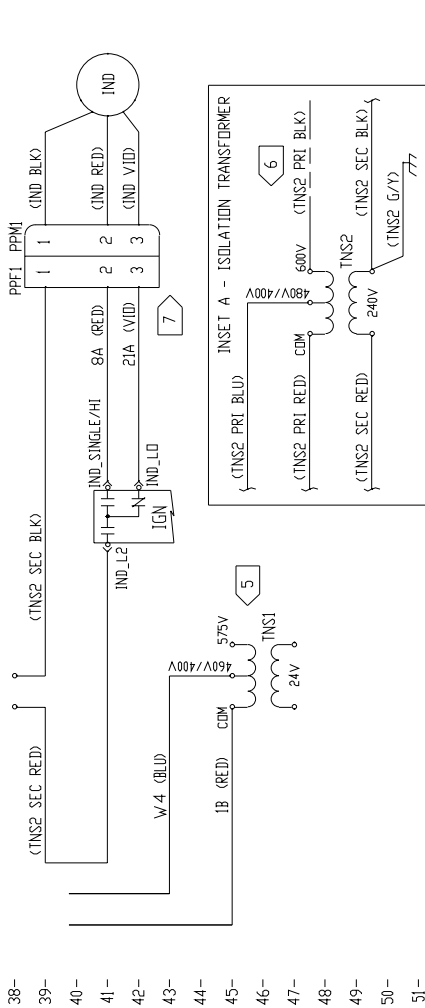
**IMPORTANT!**

DO NOT ENERGIZE UNIT UNTIL CHECK-OUT AND START-UP PROCEDURE HAS BEEN COMPLETED.

**Diagram 10**  
**Power Schematic - 460-575v/60hz/3ph**  
**2 - 7.5 Ton Single Stage Gas Heat / Belt Drive Motor**  
**4366-1005**







REF	DESCRIPTION	LINE
CCI	COMPRESSOR CONTACTOR	17/19/31
CCH	CRANKCASE HEATER	21
CF1	OD MOTOR CAPACITOR	31
CPRI	COMPRESSOR	17
CYL	COIL TEMP LIMIT SWITCH	21
F	FAN CONTACTOR	10/12
IDM	ID FAN MOTOR	10
IGN	IGNITION MODULE	41-42
IND	INDUCER MOTOR	41
DDF2	DD FAN SPEED RELAY	33-35
DDM	DD FAN MOTOR	32
TNS1	LOW VOLTAGE TRANSFORMER	45-47
TNS2	INDUCER AUTOTRANSFORMER	37-38

COLOR	ABBR	COLOR	ABBR
BLACK	BLK	ORANGE	ORG
BLUE	BLU	RED	RED
BROWN	BRN	VIOLET (PURPLE)	VIO
GRAY (SLATE)	GRA	WHITE	WHT
GREEN/YELLOW	G/Y	YELLOW	YEL

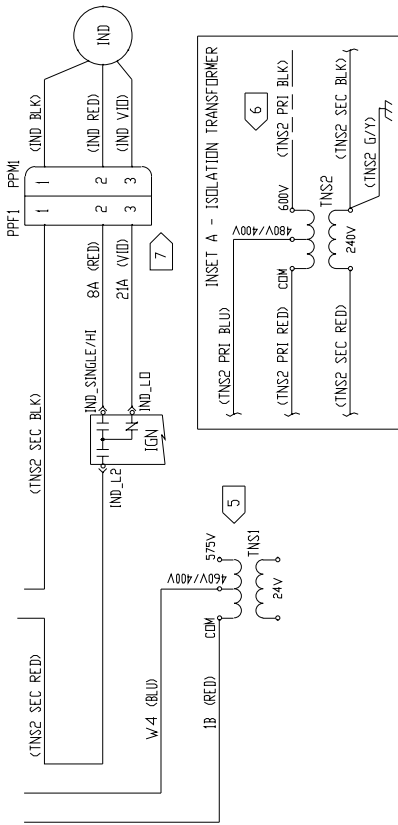
**IMPORTANT!**  
DO NOT ENERGIZE UNIT UNTIL CHECK-OUT AND START-UP PROCEDURE HAS BEEN COMPLETED.

- 1 UNLESS OTHERWISE NOTED, ALL SWITCHES ARE SHOWN AT 25°C (77°F). AT ATMOSPHERIC PRESSURE, AT 50% RELATIVE HUMIDITY WITH ALL UTILITIES TURNED OFF AND AFTER A NORMAL SHUTDOWN HAS OCCURRED.
- 2 DASHED LINES INDICATE RECOMMENDED FIELD WIRING BY OTHERS. DASHED LINE ENCLOSURES AND/OR DASHED DEVICE OUTLINES INDICATE COMPONENTS PROVIDED BY THE FIELD. PHANTOM LINE ENCLOSURES INDICATE ALTERNATE CIRCUITRY OR AVAILABLE SALES OPTIONS.
- 3 NUMBERS ALONG THE RIGHT SIDE OF THE SCHEMATIC DESIGNATE THE LOCATION OF CONTACTS BY LINE NUMBER. AN UNDERLINED NUMBER INDICATES A NORMALLY CLOSED CONTACT.
- 4 THREE-PHASE MOTORS ARE PROTECTED UNDER PRIMARY SINGLE PHASING CONDITIONS. ALL MOTORS HAVE INTERNAL OVERLOAD PROTECTION AND COMPRESSORS HAVE INTERNAL THERMAL PROTECTION.
- 5 CONNECTIONS SHOWN ARE FOR 380-415V/50HZ/3PH, 380V/60HZ/3PH, AND 460V/60HZ/3PH UNITS. WHEN 575V/60HZ/3PH OPERATION IS REQUIRED, MOVE WIRE W4(BLU) FROM THE 460V TERMINAL ON TNS1 TO THE 575V TERMINAL.
- 6 CONNECTIONS SHOWN ARE FOR 380-415V/50HZ/3PH, 380V/60HZ/3PH, AND 460V/60HZ/3PH UNITS. WHEN 575V/60HZ/3PH OPERATION IS REQUIRED, REMOVE WIRE (TNS2 PRI BLU) FROM CCI-L2 AND CONNECT WIRE (TNS2 PRI BLK) TO CCI-L2.
- 7 CONNECTIONS SHOWN ARE FOR DUAL-STAGE GAS HEAT OPERATION. WHEN SINGLE-STAGE OPERATION IS REQUIRED, WIRE 21A(VID) IS NOT CONNECTED, AND WIRE (IND VID) IS NOT PRESENT.
- 8 THESE CONNECTIONS ARE FOR UNITS WITH A CRANKCASE HEATER INSTALLED. FOR 5-TON AND SMALLER UNITS, CONNECT AS SHOWN FOR UNITS LARGER THAN 5-TON. CTL AND WIRE 4(RED) ARE NOT PRESENT, AND CCH WIRES ARE CONNECTED TO CCI-L1 AND CCI-T1.
- 9 CONNECTIONS SHOWN ARE FOR DEHUMIDIFICATION OPTION (2-SPEED DDM). FOR 1-SPEED DDM, WIRES 13(RED), 32A(RED), (DDM RED), (DDM ORG), AND COMPONENT DDF2 ARE NOT PRESENT AND WIRE (DDM BLK) IS CONNECTED TO CCI-L1.

<p><b>⚠ WARNING</b> HAZARDOUS VOLTAGE! DISCONNECT ALL ELECTRIC POWER, INCLUDING REMOTE DISCONNECTS, BEFORE SERVICING. FAILURE TO DISCONNECT POWER BEFORE SERVICING CAN CAUSE SEVERE PERSONAL INJURY OR DEATH.</p>	<p><b>⚠ AVERTISSEMENT</b> VOLTAGE HASARDEUX! DECONNECTEZ TOUTES LES SOURCES ELECTRIQUES INCLUANT LES DISJONCTEURS SITUES A DISTANCE AVANT D'EFFECTUER L'ENTRETIEN. FAUTE DE DECONNECTER LA SOURCE ELECTRIQUE AVANT D'EFFECTUER L'ENTRETIEN PEUT ENTRAINER DES BLESSURES CORPORELLES SEVERES OU LA MORT.</p>
<p><b>⚠ CAUTION</b> USE COPPER CONDUCTORS ONLY! UNIT TERMINALS ARE NOT DESIGNED TO ACCEPT OTHER TYPES OF CONDUCTORS. FAILURE TO DO SO MAY CAUSE DAMAGE TO THE EQUIPMENT.</p>	<p><b>⚠ IMPORTANT!</b> DO NOT ENERGIZE UNIT UNTIL CHECK-OUT AND START-UP PROCEDURE HAS BEEN COMPLETED.</p>



38—  
39—  
40—  
41—  
42—  
43—  
44—  
45—  
46—  
47—  
48—  
49—  
50—  
51—  
52—  
53—  
54—  
55—  
56—  
57—  
58—  
59—  
60—  
61—  
62—  
63—  
64—  
65—  
66—  
67—  
68—  
69—  
70—  
71—  
72—  
73—  
74—  
75—  
76—  
77—  
78—



- 1 UNLESS OTHERWISE NOTED, ALL SWITCHES ARE SHOWN AT 25°C (77°F), AT ATMOSPHERIC PRESSURE, AT 50% RELATIVE HUMIDITY WITH ALL UTILITIES TURNED OFF AND AFTER A NORMAL SHUTDOWN HAS OCCURRED.
- 2 DASHED LINES INDICATE RECOMMENDED FIELD WIRING BY OTHERS. DASHED LINE ENCLOSURES AND/OR DASHED DEVICE OUTLINES INDICATE COMPONENTS PROVIDED BY THE FIELD. PHANTOM LINE ENCLOSURES INDICATE ALTERNATE CIRCUITRY OR AVAILABLE SALES OPTIONS.
- 3 NUMBERS ALONG THE RIGHT SIDE OF THE SCHEMATIC DESIGNATE THE LOCATION OF CONTACTS BY LINE NUMBER. AN UNDERLINED NUMBER INDICATES A NORMALLY CLOSED CONTACT.
- 4 THREE-PHASE MOTORS ARE PROTECTED UNDER SINGLE PHASING CONDITIONS. ALL MOTORS HAVE INTERNAL OVERLOAD PROTECTION AND COMPRESSORS HAVE INTERNAL THERMAL PROTECTION.
- 5 OPERATIONS SHOWN ARE FOR 380-415V/50HZ/3PH, 380V/60HZ/3PH AND 460V/60HZ/3PH UNITS. WHEN 575V/60HZ/3PH OPERATION IS REQUIRED, MOVE WIRE W4(BLU) FROM THE 460V TERMINAL ON TNS1 TO THE 575V TERMINAL.
- 6 CONNECTIONS SHOWN ARE FOR 380-415V/50HZ/3PH, 380V/60HZ/3PH AND 460V/60HZ/3PH UNITS. WHEN 575V/60HZ/3PH OPERATION IS REQUIRED, REMOVE WIRE (TNS2 PRI BLU) FROM CCI-L2 AND CONNECT WIRE (TNS2 PRI BLK) TO CCI-L2. CONNECTIONS SHOWN ARE FOR DUAL-STAGE GAS HEAT OPERATION. WHEN SINGLE-STAGE GAS HEAT OPERATION IS REQUIRED, WIRE 21A(VID) IS NOT CONNECTED TO IGN, AND WIRE (IND VID) IS NOT PRESENT.
- 8 CONNECTIONS SHOWN ARE FOR 460V/60HZ/3PH AND 575V/60HZ/3PH UNITS. FOR 380-415V/50HZ/3PH AND 380V/60HZ/3PH UNITS, CCH1 AND CCH2 ARE NOT PRESENT.

REF	DESCRIPTION	LINE
CCI	COMPRESSOR CONTACTOR 1	17/19/31
CC2	COMPRESSOR CONTACTOR 2	25/27/33
CCH1	CRANKCASE HEATER 1	21
CCH2	CRANKCASE HEATER 2	29
CFT	OD FAN CAPACITOR	31
CPR1	COMPRESSOR 1	17
CPR2	COMPRESSOR 2	25
F	FAN CONTACTOR	10,12
IDM	ID FAN MOTOR	10
IGN	IGNITION MODULE	41-42
IND	INDUCER MOTOR	41
IDM	OD FAN MOTOR	32
TNS1	LOW VOLTAGE TRANSFORMER	45-47
TNS2	INDUCER AUTOTRANSFORMER	37-38

COLOR	ABBR	COLOR	ABBR
BLACK	BLK	ORANGE	DRG
BLUE	BLU	RED	RED
BROWN	BRN	VIOLET (PURPLE)	VIO
GRAY (SLATE)	GRA	WHITE	WHT
GREEN/YELLOW	G/Y	YELLOW	YEL

**IMPORTANT!**  
DO NOT ENERGIZE UNIT UNTIL CHECK-OUT AND START-UP PROCEDURE HAS BEEN COMPLETED.

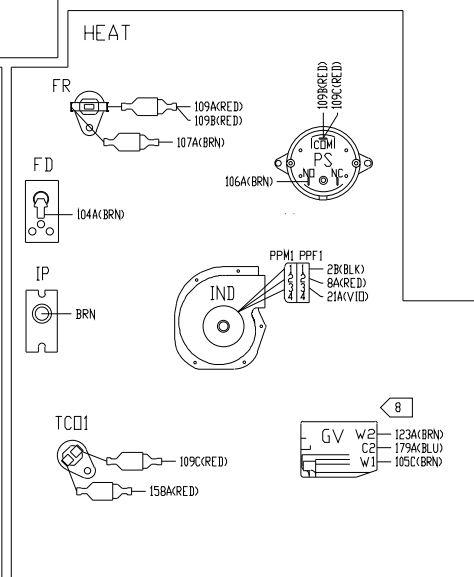
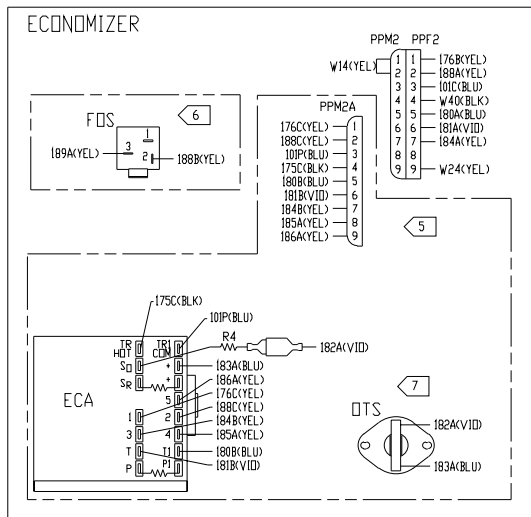
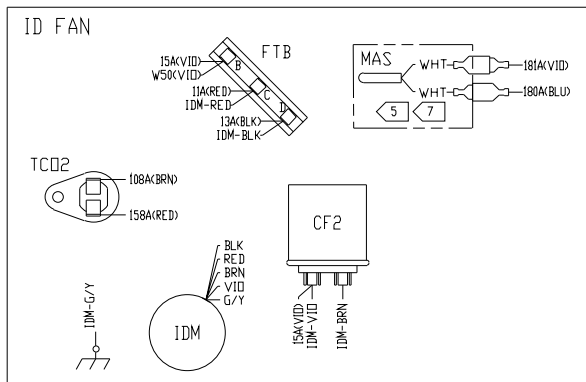
**CAUTION**  
USE COPPER CONDUCTORS ONLY! UNIT TERMINALS ARE NOT DESIGNED TO ACCEPT OTHER TYPES OF CONDUCTORS.  
FAILURE TO DO SO MAY CAUSE DAMAGE TO THE EQUIPMENT.

**AVERTISSEMENT**  
VOLTAGE HAZARDEUX!  
DECONNECTEZ TOUTES LES SOURCES ELECTRIQUES INCLUANT LES DISJONCTEURS SITUÉS A DISTANCE AVANT D'EFFECTUER L'ENTRETIEN.  
FAUTE DE DECONNECTEZ LA SOURCE ELECTRIQUE AVANT D'EFFECTUER L'ENTRETIEN PEUT ENTRAINER DES BLESSURES CORPORELLES SEVERES OU LA MORT.

**WARNING**  
HAZARDOUS VOLTAGE!  
DISCONNECT ALL ELECTRIC POWER, INCLUDING REMOTE DISCONNECTS, BEFORE SERVICING.  
FAILURE TO DISCONNECT POWER BEFORE SERVICING CAN CAUSE SEVERE PERSONAL INJURY OR DEATH.

**Diagram 12**  
**Connection Schematic - 230v/60hz/1ph**  
**Single Stage Gas Heat / Direct Drive**  
**4366-1500**

1. ALL WIRING AND DEVICES SHOWN DASHED TO BE SUPPLIED AND INSTALLED BY THE CUSTOMER IN ACCORDANCE WITH LOCAL AND NATIONAL ELECTRICAL CODES. PHANTOM LINE ENCLOSURES INDICATE ALTERNATE CIRCUITRY OR AVAILABLE SALES OPTIONS.
2. IF ANY OF THE ORIGINAL WIRE, AS SUPPLIED WITH THIS UNIT, MUST BE REPLACED, REPLACE WITH APPLIANCE WIRING MATERIAL RATED AT 105°C.
3. THREE PHASE MOTORS ARE PROTECTED UNDER PRIMARY SINGLE PHASING CONDITIONS. ALL MOTORS HAVE INTERNAL OVERLOAD PROTECTION. COMPRESSORS HAVE INTERNAL THERMAL PROTECTION.
4. CONNECTIONS SHOWN ARE FOR 230V/60HZ/1PH UNITS. WHEN 208V/60HZ/1PH OPERATION IS REQUIRED, MOVE WIRE W9(CBLK) FROM THE 230V TERMINAL ON TNS1 TO THE 208V TERMINAL.
5. WHEN INSTALLING ECONOMIZER, REMOVE PPM2 FROM PPF2, CONNECT PPM2A TO PPF2, AND CONNECT MAS TO WIRES 180A(BLU) AND 181A(VID).
6. CONNECTIONS SHOWN INCLUDE FDS AND HPC1. IF NEITHER OPTION IS INSTALLED, CONNECT WIRE LPC1-BLU TO WIRES W24/188A. IF ONLY FDS IS INSTALLED, CONNECT WIRE 189A TO WIRE LPC1-BLU. IF ONLY HPC1 IS INSTALLED, CONNECT WIRE HPC1-BLK TO WIRES W24/188A.
7. FOR MOTORIZED OUTSIDE AIR DAMPER, OPTIONAL MAS AND OTS (AND ASSOCIATED WIRING) ARE NOT USED, AND R4 IS REMOVED BETWEEN SO AND + DN ECA.
8. (FUTURE OPTION) CONNECTIONS SHOWN ARE FOR 2-STAGE GAS HEAT OPERATION WHEN 1-STAGE OPERATION IS REQUIRED, WIRE 102B IS REMOVED, WIRES 21A, 101NN, AND 174A ARE NOT CONNECTED TO IGN, WIRE 123A IS NOT CONNECTED TO GV, AND WIRE 105C IS CONNECTED TO GV-MI (NOT SHOWN).



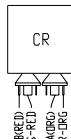
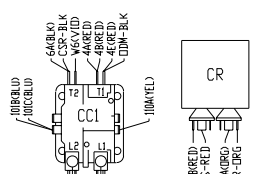
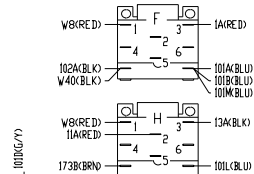
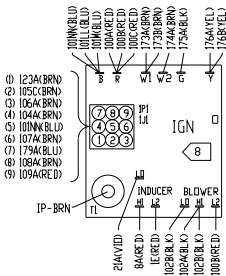
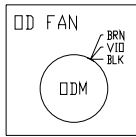
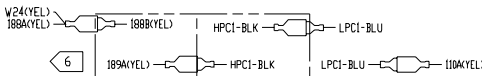
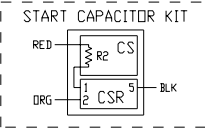
**⚠ WARNING**  
**HAZARDOUS VOLTAGE!**  
 DISCONNECT ALL ELECTRIC POWER, INCLUDING REMOTE DISCONNECTS, BEFORE SERVICING.  
 FAILURE TO DISCONNECT POWER BEFORE SERVICING CAN CAUSE SEVERE PERSONAL INJURY OR DEATH.

**⚠ AVERTISSEMENT**  
**VOLTAGE HASARDEUX!**  
 DECONNECTEZ TOUTES LES SOURCES ELECTRIQUES INCLUANT LES DISJONCTEURS SITUÉS A DISTANCE AVANT D'EFFECTUER L'ENTRETIEN.  
 FAUTE DE DECONNECTER LA SOURCE ELECTRIQUE AVANT D'EFFECTUER L'ENTRETIEN PEUT ENTRAÎNER DES BLESSURES CORPORELLES SEVERES OU LA MORT.

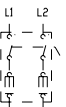
**⚠ CAUTION**  
 USE COPPER CONDUCTORS ONLY!  
 UNIT TERMINALS ARE NOT DESIGNED TO ACCEPT OTHER TYPES OF CONDUCTORS.  
 FAILURE TO DO SO MAY CAUSE DAMAGE TO THE EQUIPMENT.

**IMPORTANT!**  
 DO NOT ENERGIZE UNIT UNTIL CHECK-OUT AND START-UP PROCEDURE HAS BEEN COMPLETED.

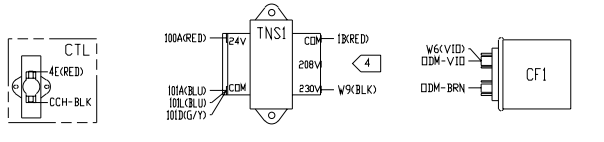
**CONTROL PANEL**



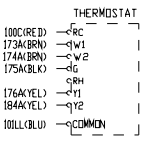
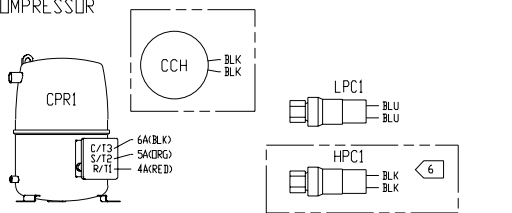
SEE NAMEPLATE FOR LINE VOLTAGE AND MAX FUSE SIZE



**CONTROL PANEL: BOTTOM**

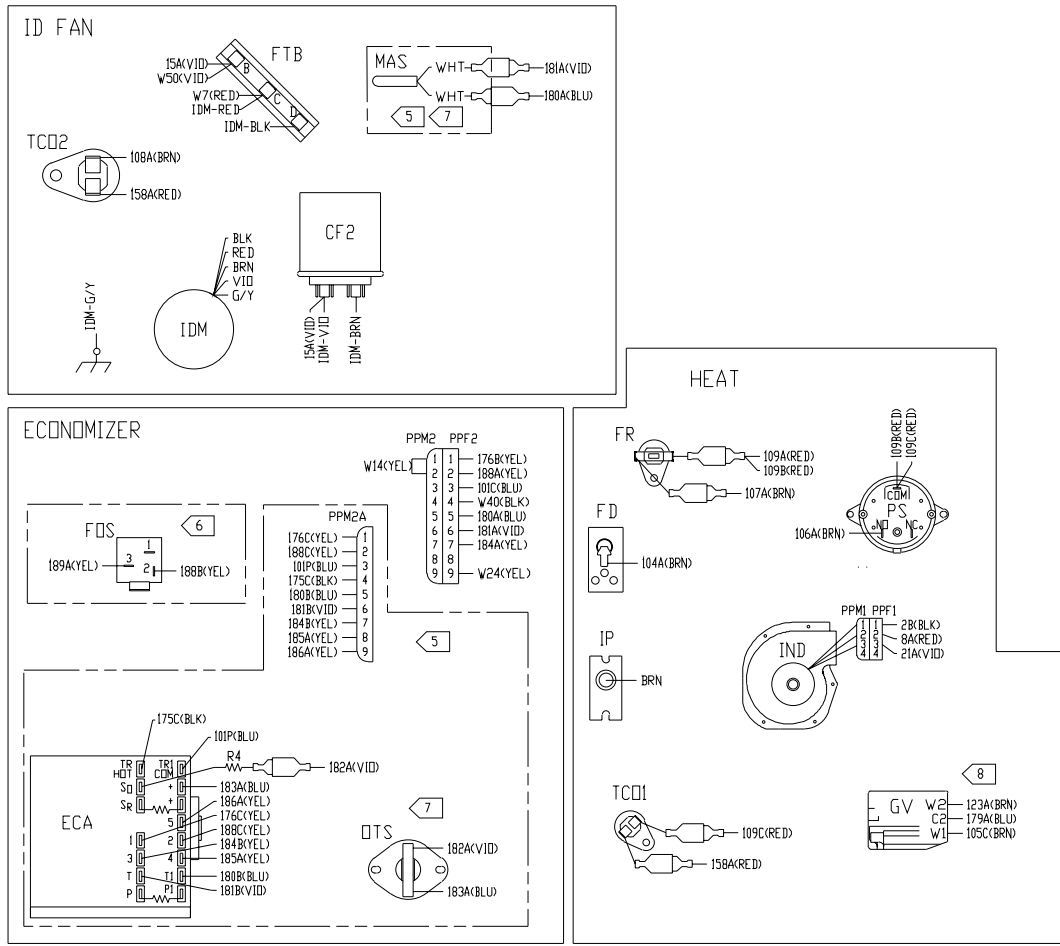


**COMPRESSOR**



**Diagram 13**  
**Connection Diagram - 230v/60hz/1ph**  
**Single Stage Gas Heat / Oversize Motor**  
**4366-1519**

1. ALL WIRING AND DEVICES SHOWN DASHED TO BE SUPPLIED AND INSTALLED BY THE CUSTOMER IN ACCORDANCE WITH LOCAL AND NATIONAL ELECTRICAL CODES. PHANTOM LINE ENCLOSURES INDICATE ALTERNATE CIRCUITRY OR AVAILABLE SALES OPTIONS.
2. IF ANY OF THE ORIGINAL WIRE, AS SUPPLIED WITH THIS UNIT, MUST BE REPLACED, REPLACE WITH APPLIANCE WIRING MATERIAL RATED AT 105°C.
3. THREE PHASE MOTORS ARE PROTECTED UNDER PRIMARY SINGLE PHASING CONDITIONS. ALL MOTORS HAVE INTERNAL OVERLOAD PROTECTION. COMPRESSORS HAVE INTERNAL THERMAL PROTECTION.
4. CONNECTIONS SHOWN ARE FOR 230V//60HZ/1PH UNITS. WHEN 208V//60HZ/1PH OPERATION IS REQUIRED, MOVE WIRE W9(BLK) FROM THE 230V TERMINAL ON TNS1 TO THE 208V TERMINAL.
5. WHEN INSTALLING ECONOMIZER, REMOVE PPM2 FROM PPF2, CONNECT PPM2A TO PPF2, AND CONNECT MAS TO WIRES 180A(BLU) AND 181A(VID).
6. CONNECTIONS SHOWN INCLUDE FDS AND HPC1. IF NEITHER OPTION IS INSTALLED, CONNECT WIRE LPC1-BLU TO WIRES W24/188A. IF ONLY FDS IS INSTALLED, CONNECT WIRE 189A TO WIRE LPC1-BLU. IF ONLY HPC1 IS INSTALLED, CONNECT WIRE HPC1-BLK TO WIRES W24/188A.
7. FOR MOTORIZED OUTSIDE AIR DAMPER, OPTIONAL MAS AND OTS (AND ASSOCIATED WIRING) ARE NOT USED, AND R4 IS REMOVED BETWEEN S0 AND + ON ECA.
8. (FUTURE OPTION) CONNECTIONS SHOWN ARE FOR 2-STAGE GAS HEAT OPERATION. WHEN 1-STAGE OPERATION IS REQUIRED, WIRE 102B IS REMOVED, WIRES 21A, 101NN, AND 174A ARE NOT CONNECTED TO IGN, WIRE 123A IS NOT CONNECTED TO GV, AND WIRE 105C IS CONNECTED TO GV-MI (NOT SHOWN).



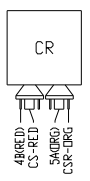
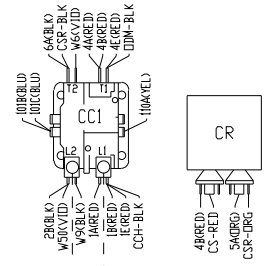
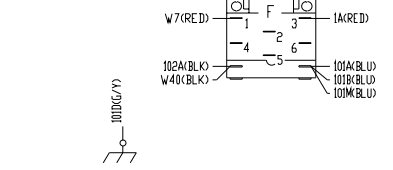
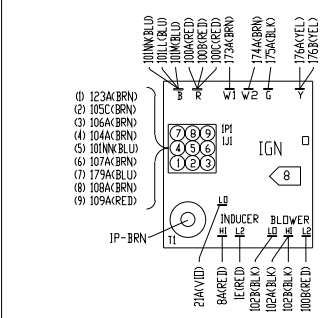
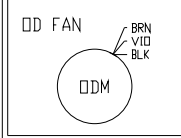
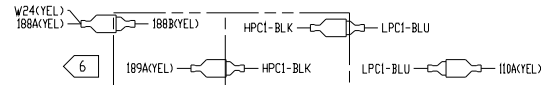
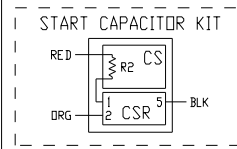
**⚠ WARNING**  
**HAZARDOUS VOLTAGE!**  
 DISCONNECT ALL ELECTRIC POWER, INCLUDING REMOTE DISCONNECTS, BEFORE SERVICING.  
 FAILURE TO DISCONNECT POWER BEFORE SERVICING CAN CAUSE SEVERE PERSONAL INJURY OR DEATH.

**⚠ AVERTISSEMENT**  
**VOLTAGE HASARDEUX!**  
 DECONNECTEZ TOUTES LES SOURCES ELECTRIQUES INCLUANT LES DISJONCTEURS SITUÉS A DISTANCE AVANT D'EFFECTUER L'ENTRETIEN.  
 FAUTE DE DECONNECTER LA SOURCE ELECTRIQUE AVANT D'EFFECTUER L'ENTRETIEN PEUT ENTRAINER DES BLESSURES CORPORELLES SEVERES OU LA MORT.

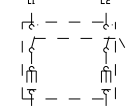
**⚠ CAUTION**  
 USE COPPER CONDUCTORS ONLY!  
 UNIT TERMINALS ARE NOT DESIGNED TO ACCEPT OTHER TYPES OF CONDUCTORS.  
 FAILURE TO DO SO MAY CAUSE DAMAGE TO THE EQUIPMENT.

**IMPORTANT!**  
 DO NOT ENERGIZE UNIT UNTIL CHECK-OUT AND START-UP PROCEDURE HAS BEEN COMPLETED.

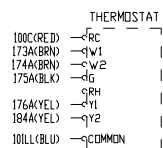
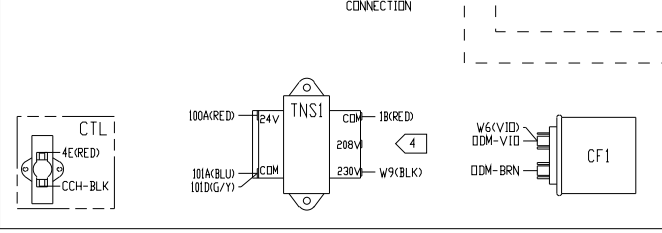
**CONTROL PANEL**



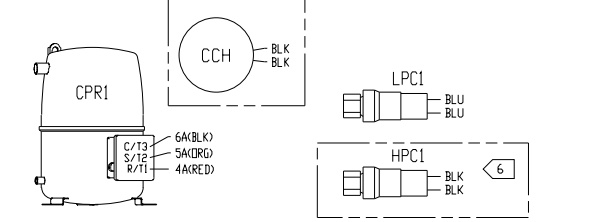
SEE NAMEPLATE FOR LINE VOLTAGE AND MAX FUSE SIZE



**CONTROL PANEL: BOTTOM**

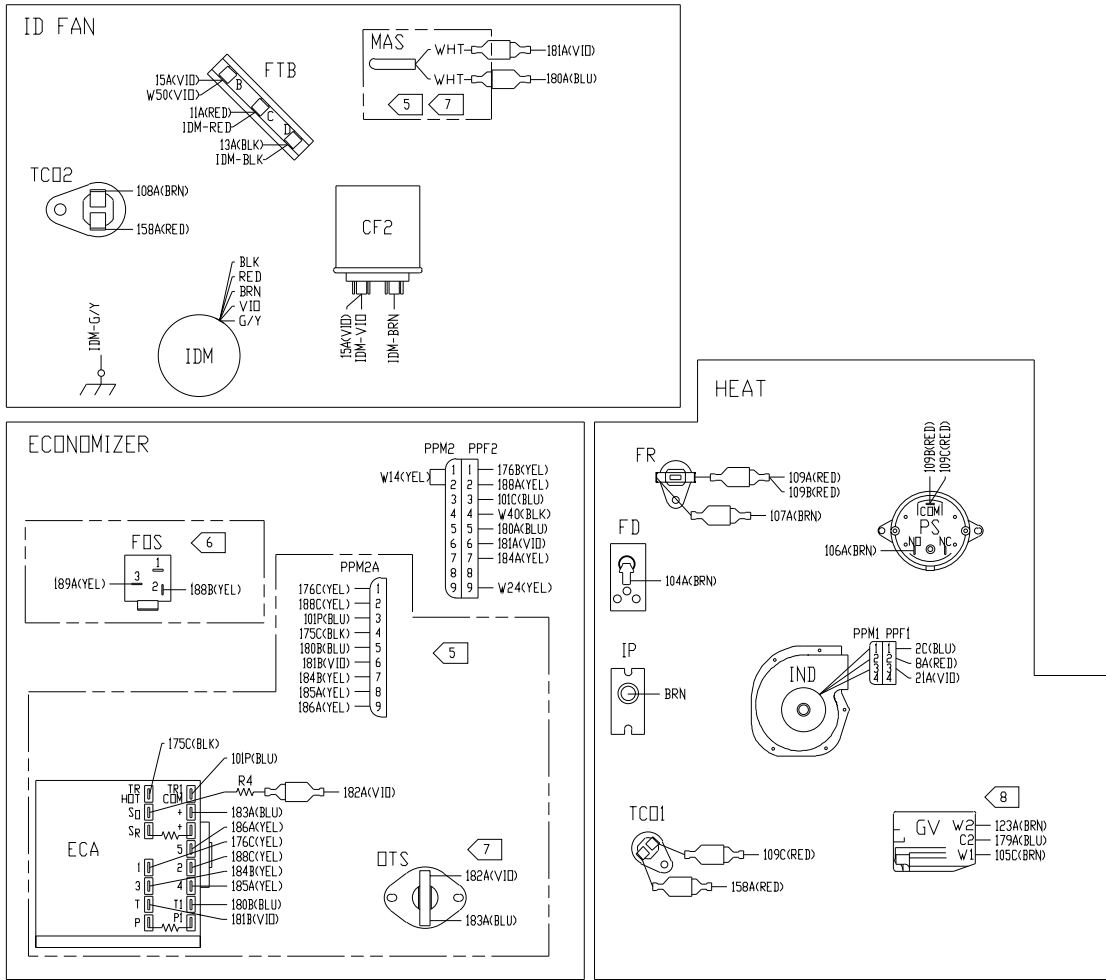


**COMPRESSOR**



**Diagram 14**  
**Connection Diagram - 230v/60hz/3ph**  
**Single Stage Gas Heat / Direct Drive**  
**4366-1502**

1. ALL WIRING AND DEVICES SHOWN DASHED TO BE SUPPLIED AND INSTALLED BY THE CUSTOMER IN ACCORDANCE WITH LOCAL AND NATIONAL ELECTRICAL CODES. PHANTOM LINE ENCLOSURES INDICATE ALTERNATE CIRCUITRY OR AVAILABLE SALES OPTIONS.
2. IF ANY OF THE ORIGINAL WIRE, AS SUPPLIED WITH THIS UNIT, MUST BE REPLACED, REPLACE WITH APPLIANCE WIRING MATERIAL RATED AT 105°C.
3. THREE PHASE MOTORS ARE PROTECTED UNDER PRIMARY SINGLE PHASING CONDITIONS. ALL MOTORS HAVE INTERNAL OVERLOAD PROTECTION. COMPRESSORS HAVE INTERNAL THERMAL PROTECTION.
4. CONNECTIONS SHOWN ARE FOR 230V/60HZ/3PH UNITS. WHEN 208V/60HZ/3PH OPERATION IS REQUIRED, MOVE WIRE W4(BLU) FROM THE 230V TERMINAL ON TNS1 TO THE 208V TERMINAL.
5. WHEN INSTALLING ECONMIZER, REMOVE PPM2 FROM PPF2, CONNECT PPM2A TO PPF2, AND CONNECT MAS TO WIRES 180A(BLU) AND 181A(VID).
6. CONNECTIONS SHOWN INCLUDE FDS AND HPC1. IF NEITHER OPTION IS INSTALLED, CONNECT WIRE LPC1-BLU TO WIRES W24/189A. IF ONLY FDS IS INSTALLED, CONNECT WIRE 189A TO WIRE LPC1-BLU. IF ONLY HPC1 IS INSTALLED, CONNECT HPC1-BLK TO WIRES W24/188A.
7. FOR MOTORIZED OUTSIDE AIR DAMPER, OPTIONAL MAS AND OTS (AND ASSOCIATED WIRING) ARE NOT USED, AND R4 IS REMOVED BETWEEN S0 AND + ON ECA.
8. (FUTURE OPTION) CONNECTIONS SHOWN ARE FOR 2-STAGE GAS HEAT OPERATION. WHEN 1-STAGE OPERATION IS REQUIRED, WIRE 102B IS REMOVED, WIRES 21A, 101NN, AND 174A ARE NOT CONNECTED TO IGN, WIRE 123A IS NOT CONNECTED TO GV, AND WIRE 105C IS CONNECTED TO GV-MI (NOT SHOWN).

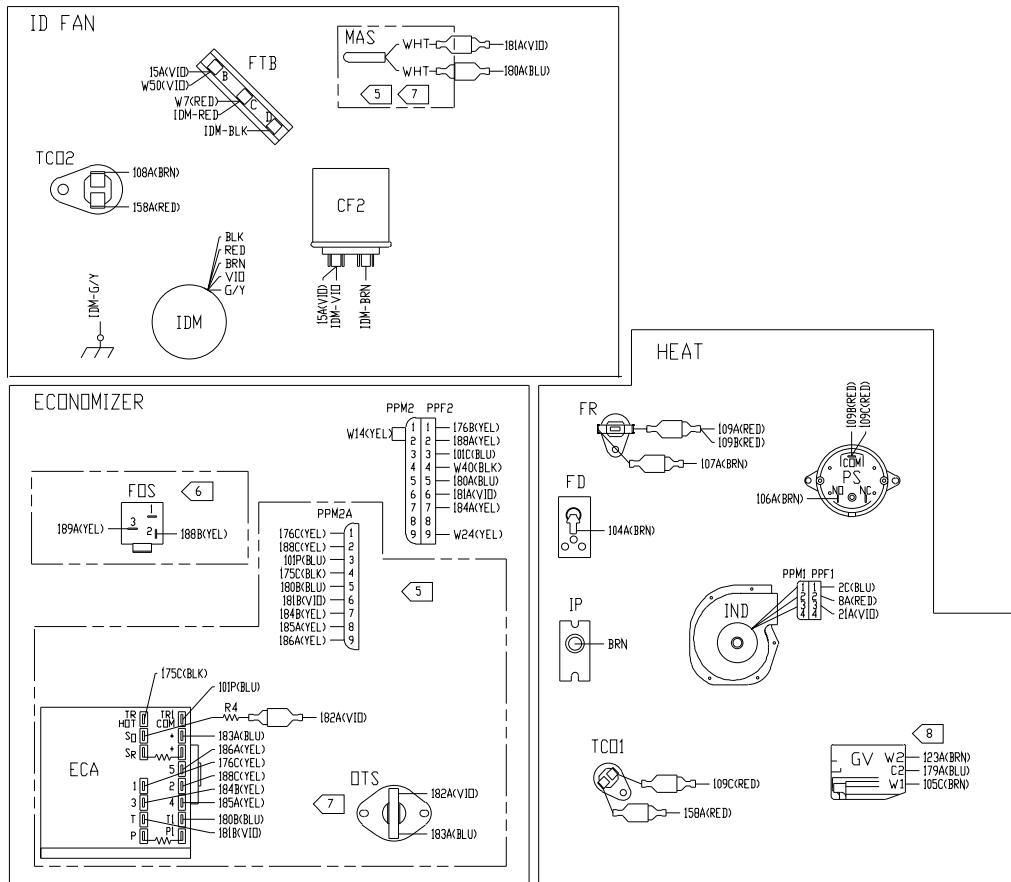






**Diagram 15**  
**Connection Diagram - 230v/60hz/3ph**  
**Single Stage Gas Heat / Oversize Motor**  
**4366-1525**

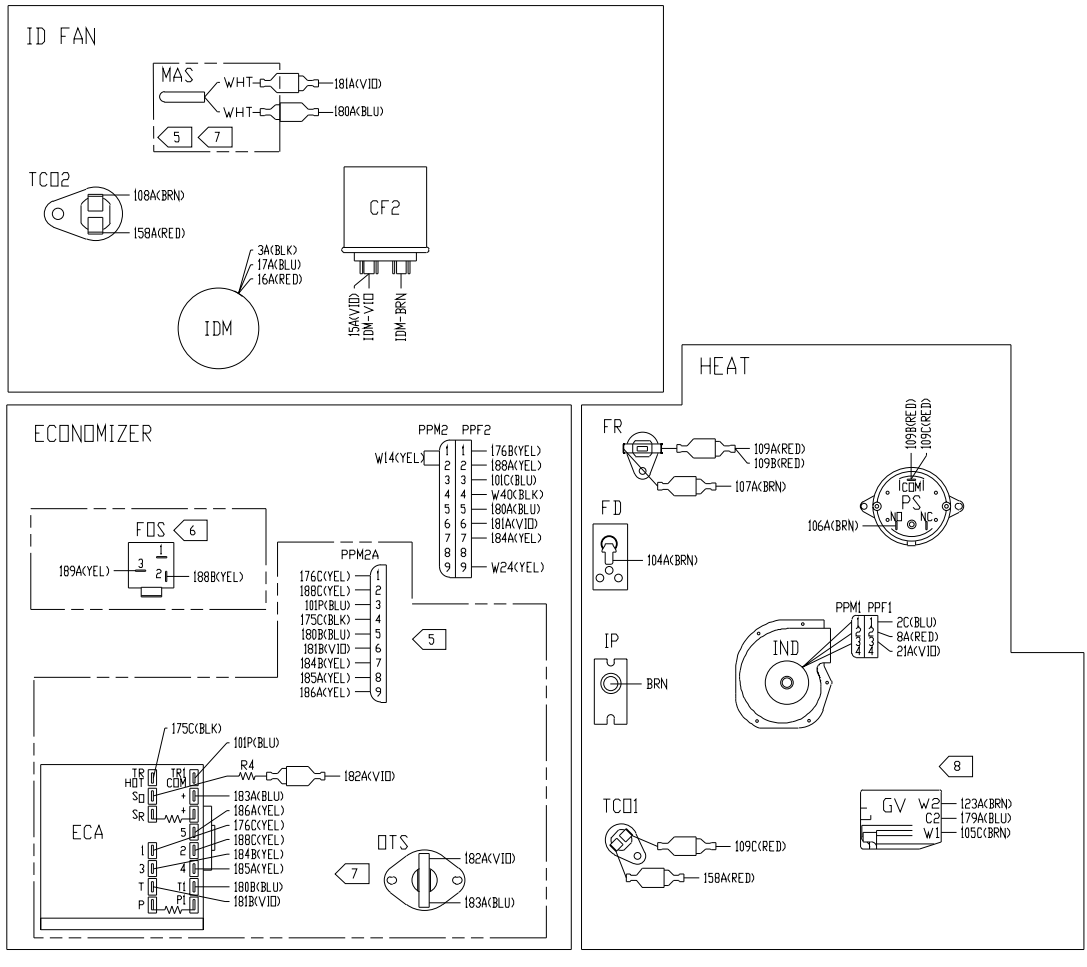
1. ALL WIRING AND DEVICES SHOWN DASHED TO BE SUPPLIED AND INSTALLED BY THE CUSTOMER IN ACCORDANCE WITH LOCAL AND NATIONAL ELECTRICAL CODES. PHANTOM LINE ENCLOSURES INDICATE ALTERNATE CIRCUITRY OR AVAILABLE SALES OPTIONS.
2. IF ANY OF THE ORIGINAL WIRE, AS SUPPLIED WITH THIS UNIT, MUST BE REPLACED, REPLACE WITH APPLIANCE WIRING MATERIAL RATED AT 105°C.
3. THREE PHASE MOTORS ARE PROTECTED UNDER PRIMARY SINGLE PHASING CONDITIONS. ALL MOTORS HAVE INTERNAL OVERLOAD PROTECTION. COMPRESSORS HAVE INTERNAL THERMAL PROTECTION.
4. CONNECTIONS SHOWN ARE FOR 230V/60HZ/3PH UNITS. WHEN 208V/60HZ/3PH OPERATION IS REQUIRED, MOVE WIRE W4(BLU) FROM THE 230V TERMINAL ON TNS1 TO THE 208V TERMINAL.
5. WHEN INSTALLING ECONOMIZER, REMOVE PPM2 FROM PPF2, CONNECT PPM2A TO PPF2, AND CONNECT MAS TO WIRES 180A(BLU) AND 181A(VID).
6. CONNECTIONS SHOWN INCLUDE FOS AND HPCI. IF NEITHER OPTION IS INSTALLED, CONNECT WIRE LPC1-BLU TO WIRES W24/188A. IF ONLY FOS IS INSTALLED, CONNECT WIRE 189A TO WIRE LPC1-BLU. IF ONLY HPCI IS INSTALLED, CONNECT WIRE HPCI-BLK TO WIRES W24/188A.
7. FOR MOTORIZED OUTSIDE AIR DAMPER, OPTIONAL MAS AND ODS (AND ASSOCIATED WIRING) ARE NOT USED, AND R4 IS REMOVED BETWEEN SO AND + ON ECA.
8. (FUTURE OPTION) CONNECTIONS SHOWN ARE FOR 2-STAGE GAS HEAT OPERATION. WHEN 1-STAGE OPERATION IS REQUIRED, WIRE 102B IS REMOVED, WIRES 21A, 101N, AND 174A ARE NOT CONNECTED TO 10N, WIRE 123A IS NOT CONNECTED TO GV, AND WIRE 105C IS CONNECTED TO GV-MI (NOT SHOWN).





**Diagram 16**  
**Connection Diagram - 230v/60hz/3ph**  
**Single Stage Gas Heat / Belt Drive**  
**4366-1521**

1. ALL WIRING AND DEVICES SHOWN DASHED TO BE SUPPLIED AND INSTALLED BY THE CUSTOMER IN ACCORDANCE WITH LOCAL AND NATIONAL ELECTRICAL CODES. PHANTOM LINE ENCLOSURES INDICATE ALTERNATE CIRCUITRY OR AVAILABLE SALES OPTIONS.
2. IF ANY OF THE ORIGINAL WIRE, AS SUPPLIED WITH THIS UNIT, MUST BE REPLACED, REPLACE WITH APPLIANCE WIRING MATERIAL RATED AT 105°C.
3. THREE PHASE MOTORS ARE PROTECTED UNDER PRIMARY SINGLE PHASING CONDITIONS. ALL MOTORS HAVE INTERNAL OVERLOAD PROTECTION. COMPRESSORS HAVE INTERNAL THERMAL PROTECTION.
4. CONNECTIONS SHOWN ARE FOR 230V/60HZ/3PH UNITS. WHEN 208V/60HZ/3PH OPERATION IS REQUIRED, MOVE WIRE W4(BLU) FROM THE 230V TERMINAL ON TNS1 TO THE 208V TERMINAL.
5. WHEN INSTALLING ECONOMIZER, REMOVE PPM2 FROM PPF2, CONNECT PPM2A TO PPF2, AND CONNECT MAS TO WIRES 180A(BLU) AND 181A(VID).
6. CONNECTIONS SHOWN INCLUDE FOS AND HPC1. IF NEITHER OPTION IS INSTALLED, CONNECT WIRE LPC1-BLU TO WIRES W24/188A. IF ONLY FOS IS INSTALLED, CONNECT WIRE 189A TO WIRE LPC1-BLU. IF ONLY HPC1 IS INSTALLED, CONNECT WIRE HPC1-BLK TO WIRES W24/188A.
7. FOR MOTORIZED OUTSIDE AIR DAMPER, OPTIONAL MAS AND OTS (AND ASSOCIATED WIRING) ARE NOT USED, AND R4 IS REMOVED BETWEEN S0 AND + ON ECA.
8. (FUTURE OPTION) CONNECTIONS SHOWN ARE FOR 2-STAGE GAS HEAT OPERATION. WHEN 1-STAGE OPERATION IS REQUIRED, WIRE 102B IS REMOVED, WIRES 21A, 101NN, AND 174A ARE NOT CONNECTED TO IGN, WIRE 123A IS NOT CONNECTED TO GV, AND WIRE 105C IS CONNECTED TO GV-M1 (NOT SHOWN).



**⚠ WARNING**  
**HAZARDOUS VOLTAGE!**  
 DISCONNECT ALL ELECTRIC POWER, INCLUDING REMOTE DISCONNECTS, BEFORE SERVICING.

FAILURE TO DISCONNECT POWER BEFORE SERVICING CAN CAUSE SEVERE PERSONAL INJURY OR DEATH.

**⚠ AVERTISSEMENT**  
**VOLTAGE HASARDEUX!**  
 DECONNECTEZ TOUTES LES SOURCES ELECTRIQUES INCLUANT LES DISJONCTEURS SITUÉS A DISTANCE AVANT D'EFFECTUER L'ENTRETIEN.

FAUTE DE DECONNECTER LA SOURCE ELECTRIQUE AVANT D'EFFECTUER L'ENTRETIEN PEUT ENTRAÎNER DES BLESSURES CORPORELLES SEVERES OU LA MORT.

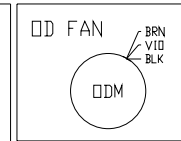
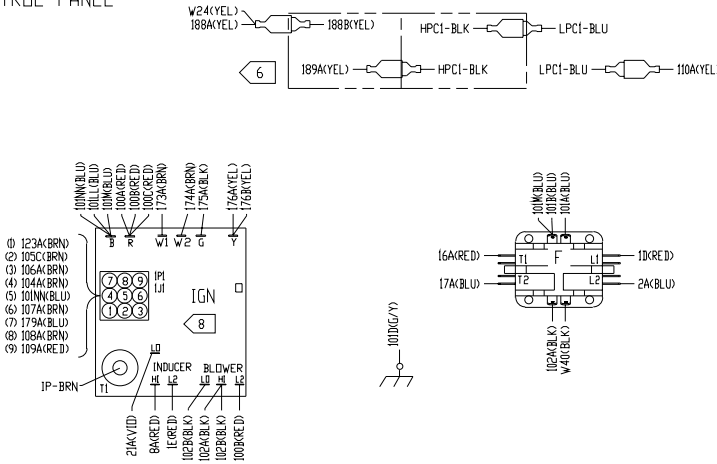
**⚠ CAUTION**  
 USE COPPER CONDUCTORS ONLY!  
 UNIT TERMINALS ARE NOT DESIGNED TO ACCEPT OTHER TYPES OF CONDUCTORS.

FAILURE TO DO SO MAY CAUSE DAMAGE TO THE EQUIPMENT.

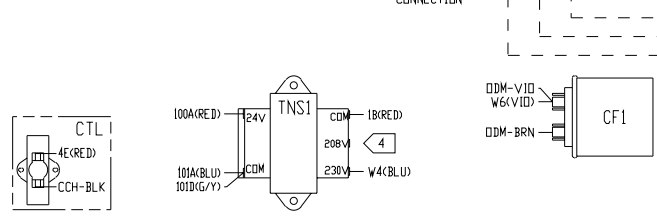
**IMPORTANT!**

DO NOT ENERGIZE UNIT UNTIL CHECK-OUT AND START-UP PROCEDURE HAS BEEN COMPLETED.

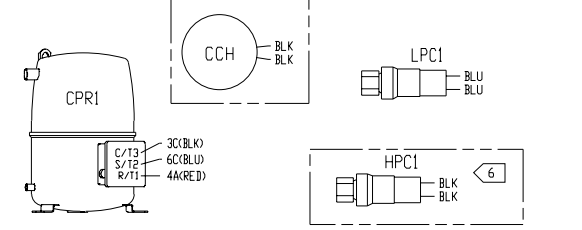
**CONTROL PANEL**



**CONTROL PANEL: BOTTOM**

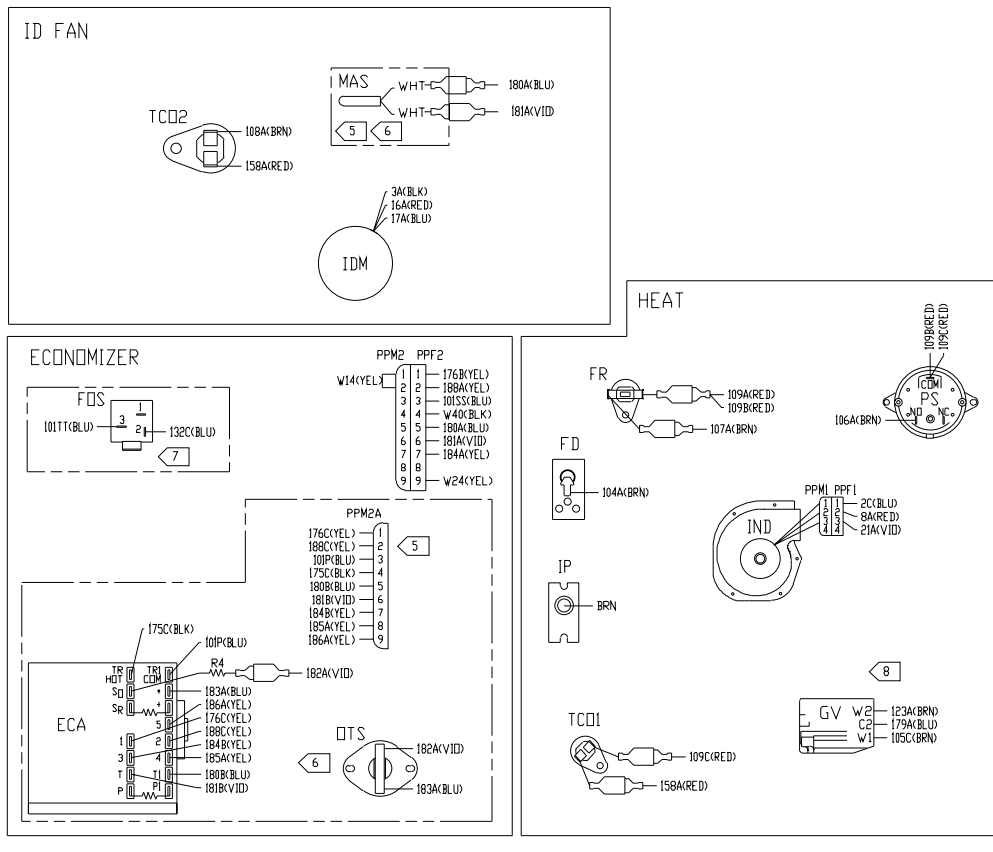


**COMPRESSOR**



**Diagram 17**  
**Connection Diagram - 230v/60hz/3ph**  
**6 - 7.5 Ton Gas Heat / Single Compressor**  
**4366-1537**

1. ALL WIRING AND DEVICES SHOWN DASHED TO BE SUPPLIED AND INSTALLED BY THE CUSTOMER IN ACCORDANCE WITH LOCAL AND NATIONAL ELECTRICAL CODES. PHANTOM LINE ENCLOSURES INDICATE ALTERNATE CIRCUITRY OR AVAILABLE SALES OPTIONS.
2. IF ANY OF THE ORIGINAL WIRE, AS SUPPLIED WITH THIS UNIT, MUST BE REPLACED, REPLACE WITH APPLIANCE WIRING MATERIAL RATED AT 105°C.
3. THREE PHASE MOTORS ARE PROTECTED UNDER PRIMARY SINGLE PHASING CONDITIONS. ALL MOTORS HAVE INTERNAL OVERLOAD PROTECTION. COMPRESSORS HAVE INTERNAL THERMAL PROTECTION.
4. CONNECTIONS SHOWN ARE FOR 230V/60HZ/3PH UNITS. WHEN 208V/60HZ/3PH OPERATION IS REQUIRED, MOVE WIRE W4(BLU) FROM THE 230V TERMINAL ON TNS1 TO THE 208V TERMINAL.
5. WHEN INSTALLING ECONOMIZER, REMOVE PPM2 FROM PPF2, CONNECT PPM2A TO PPF2, AND CONNECT MAS TO WIRES 180A(BLU) AND 181A(VID).
6. FOR MOTORIZED OUTSIDE AIR DAMPER, OPTIONAL MAS AND OTS (AND ASSOCIATED WIRING) ARE NOT USED, AND R4 IS REMOVED BETWEEN SO AND + ON ECA.
7. CONNECTIONS SHOW OPTIONAL FDS INSTALLED. IF NOT INSTALLED, CONNECT WIRE W27 TO WIRE 132A.
8. CONNECTIONS SHOWN ARE FOR 2-STAGE GAS HEAT OPERATION. WHEN 1-STAGE OPERATION IS REQUIRED, WIRE 102B IS REMOVED, WIRES 21A, 101NN, AND 174A ARE NOT CONNECTED TO IGN, WIRE 123A IS NOT CONNECTED TO GV, AND WIRE 105C IS CONNECTED TO GV-M1 (NOT SHOWN).



**⚠ WARNING**  
**HAZARDOUS VOLTAGE!**  
 DISCONNECT ALL ELECTRIC POWER, INCLUDING REMOTE DISCONNECTS, BEFORE SERVICING.

FAILURE TO DISCONNECT POWER BEFORE SERVICING CAN CAUSE SEVERE PERSONAL INJURY OR DEATH.

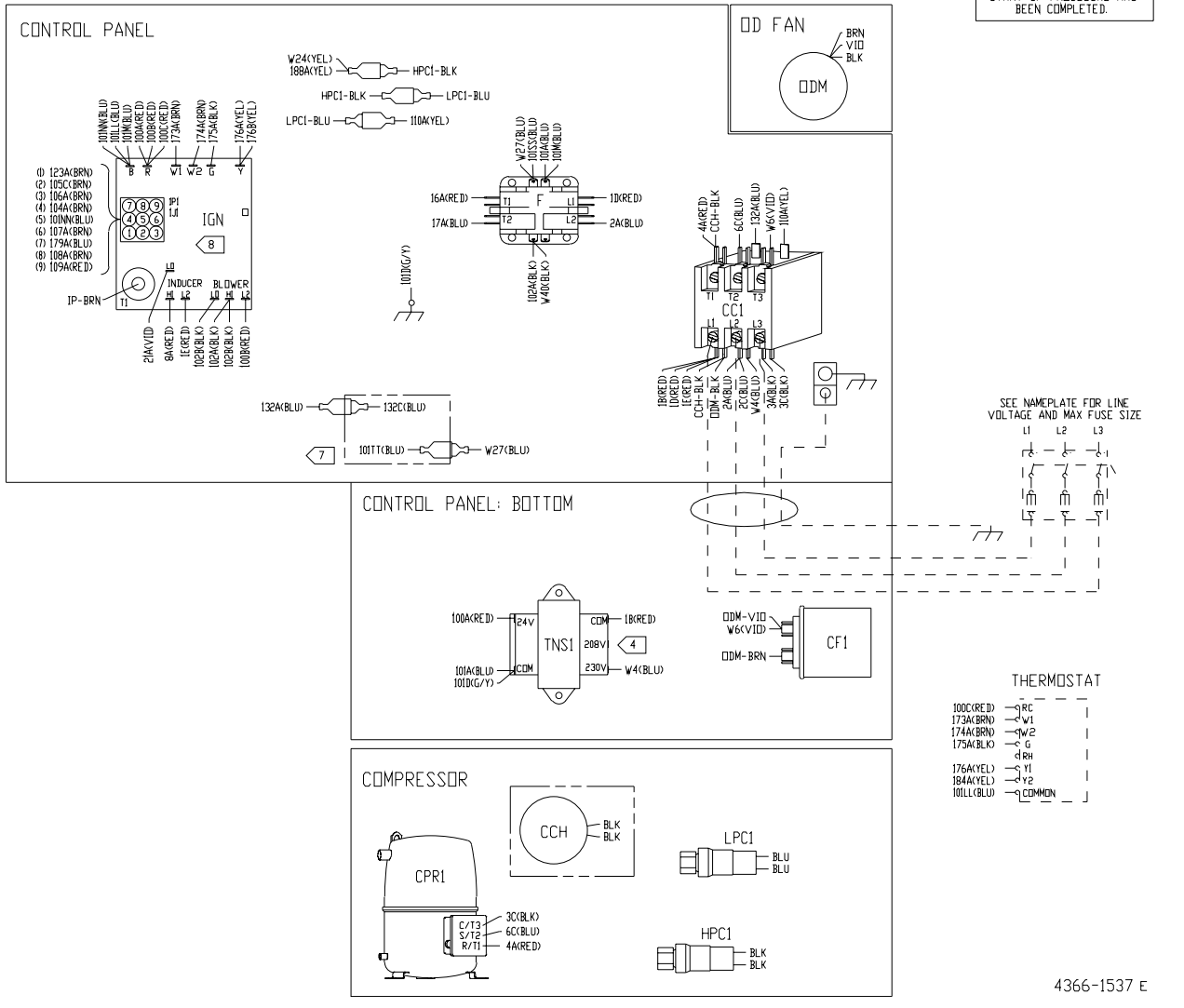
**⚠ AVERTISSEMENT**  
**VOLTAGE HASARDEUX!**  
 DECONNECTEZ TOUTES LES SOURCES ELECTRIQUES INCLUANT LES DISJONCTEURS SITUÉS A DISTANCE AVANT D'EFFECTUER L'ENTRETIEN.

FAUTE DE DECONNECTER LA SOURCE ELECTRIQUE AVANT D'EFFECTUER L'ENTRETIEN PEUT ENTRAINER DES BLESSURES CORPORELLES SEVERES OU LA MORT.

**⚠ CAUTION**  
 USE COPPER CONDUCTORS ONLY!  
 UNIT TERMINALS ARE NOT DESIGNED TO ACCEPT OTHER TYPES OF CONDUCTORS.

FAILURE TO DO SO MAY CAUSE DAMAGE TO THE EQUIPMENT.

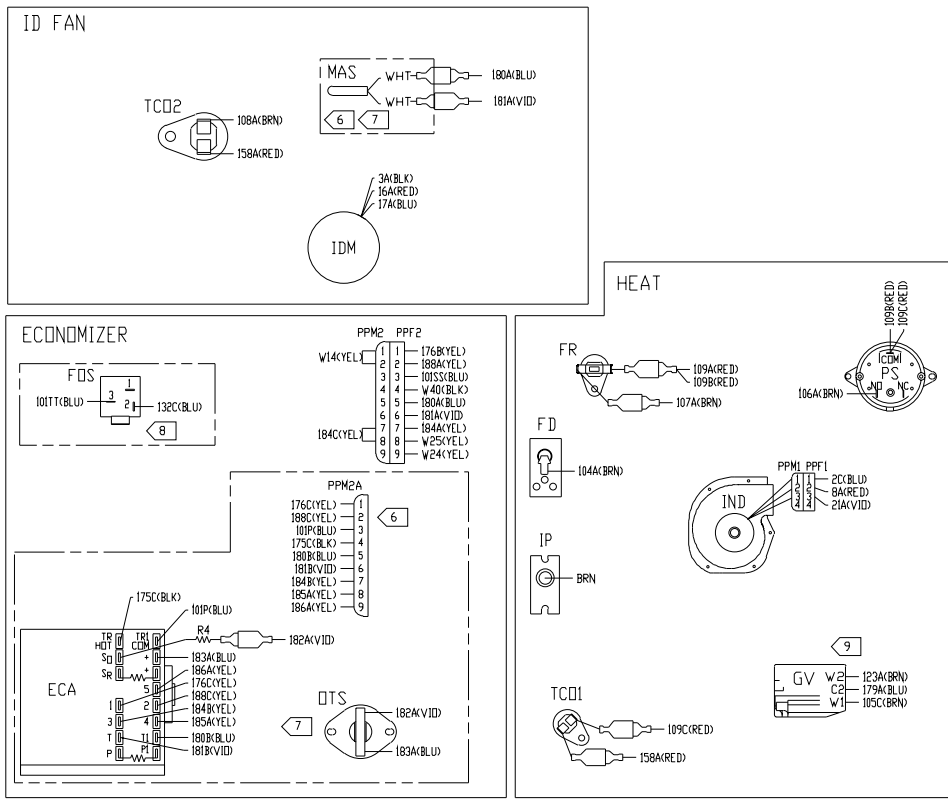
**IMPORTANT!**  
 DO NOT ENERGIZE UNIT UNTIL CHECK-OUT AND START-UP PROCEDURE HAS BEEN COMPLETED.



4366-1537 E

**Diagram 18**  
**Connection Diagram - 230v/60hz/3ph**  
**7.5 - 10 Ton Gas Heat / Dual Compressor**  
**4366-1529**

1. ALL WIRING AND DEVICES SHOWN DASHED TO BE SUPPLIED AND INSTALLED BY THE CUSTOMER IN ACCORDANCE WITH LOCAL AND NATIONAL ELECTRICAL CODES. PHANTOM LINE ENCLOSURES INDICATE ALTERNATE CIRCUITRY OR AVAILABLE SALES OPTIONS.
2. IF ANY OF THE ORIGINAL WIRE, AS SUPPLIED WITH THIS UNIT, MUST BE REPLACED, REPLACE WITH APPLIANCE WIRING MATERIAL RATED AT 105°C.
3. THREE PHASE MOTORS ARE PROTECTED UNDER PRIMARY SINGLE PHASING CONDITIONS. ALL MOTORS HAVE INTERNAL OVERLOAD PROTECTION. COMPRESSORS HAVE INTERNAL THERMAL PROTECTION.
4. CONNECTIONS SHOWN ARE FOR 230V/60HZ/3PH UNITS. WHEN 208V/60HZ/3PH OPERATION IS REQUIRED, MOVE WIRE W4(BLU) FROM THE 230V TERMINAL ON TNS1 TO THE 208V TERMINAL.
5. CCH2 CONDUCTORS ARE IDENTIFIED BY BROWN TAPE PLACED NEAR WIRE TERMINATIONS INSIDE CONTROL PANEL.
6. WHEN INSTALLING ECONOMIZER, REMOVE PPM2 FROM PPF2, CONNECT PPM2A TO PPF2, AND CONNECT MAS TO WIRES 180A(BLU) AND 181A(VID).
7. FOR MOTORIZED OUTSIDE AIR DAMPER, OPTIONAL MAS AND OTS (AND ASSOCIATED WIRING) ARE NOT USED, AND R4 IS REMOVED BETWEEN SO AND + ON ECA.
8. CONNECTIONS SHOW OPTIONAL FDS INSTALLED. IF NOT INSTALLED, CONNECT WIRE W27 TO WIRE 132A.
9. CONNECTIONS SHOWN ARE FOR 2-STAGE GAS HEAT OPERATION. WHEN 1-STAGE OPERATION IS REQUIRED, WIRE 102B IS REMOVED, WIRES 21A, 101NN, AND 174A ARE NOT CONNECTED TO IND, WIRE 123A IS NOT CONNECTED TO GV, AND WIRE 105C IS CONNECTED TO GV-M1 (NOT SHOWN).

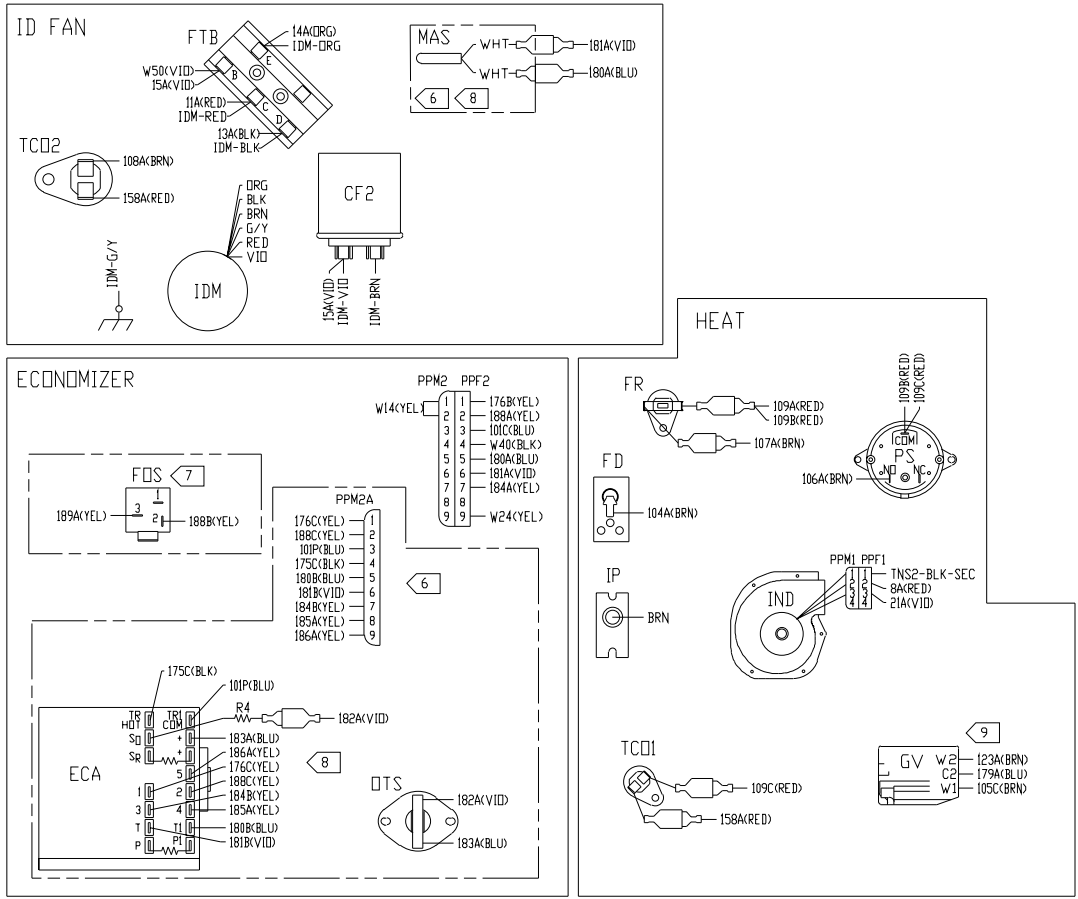






**Diagram 19**  
**Connection Diagram - 460-575v/60hz/3ph**  
**2 - 3 Ton Single Stage Gas Heat / Direct Drive**  
**4366-1513**

1. ALL WIRING AND DEVICES SHOWN DASHED TO BE SUPPLIED AND INSTALLED BY THE CUSTOMER IN ACCORDANCE WITH LOCAL AND NATIONAL ELECTRICAL CODES. PHANTOM LINE ENCLOSURES INDICATE ALTERNATE CIRCUITRY OR AVAILABLE SALES OPTIONS.
2. IF ANY OF THE ORIGINAL WIRE, AS SUPPLIED WITH THIS UNIT, MUST BE REPLACED. REPLACE WITH APPLIANCE WIRING MATERIAL RATED AT 105°C.
3. THREE PHASE MOTORS ARE PROTECTED UNDER PRIMARY SINGLE PHASING CONDITIONS. ALL MOTORS HAVE INTERNAL OVERLOAD PROTECTION. COMPRESSORS HAVE INTERNAL THERMAL PROTECTION.
4. CONNECTIONS SHOWN ARE FOR 460V/60HZ/3PH UNITS. WHEN 575V/60HZ/3PH OPERATION IS REQUIRED, MOVE WIRE W4(BLU) FROM THE 460V TERMINAL ON TNS1 TO THE 575V TERMINAL.
5. CONNECTIONS SHOWN ARE FOR 460V/60HZ/3PH UNITS. WHEN 575V/60HZ/3PH OPERATION IS REQUIRED, REMOVE WIRE TNS2-BLU-PRI FROM CC1-L2 AND CONNECT WIRE TNS2-BLK-PRI TO CC1-L2.
6. WHEN INSTALLING ECONOMIZER, REMOVE PPM2 FROM PPF2, CONNECT PPM2A TO PPF2, AND CONNECT MAS TO WIRES 180A(BLU) AND 181A(VID).
7. CONNECTIONS SHOWN INCLUDE FDS AND HPCI. IF NEITHER OPTION IS INSTALLED, CONNECT WIRE LPC1-BLU TO WIRES W24/188A. IF ONLY FDS IS INSTALLED, CONNECT WIRE 189A TO WIRE LPC1-BLU. IF ONLY HPCI IS INSTALLED, CONNECT WIRE HPCI-BLK TO WIRES W24/188A.
8. FOR MOTORIZED OUTSIDE AIR DAMPER, OPTIONAL MAS AND OTS (AND ASSOCIATED WIRING) ARE NOT USED, AND R4 IS REMOVED BETWEEN SO AND + DN ECA.
9. (FUTURE OPTION) CONNECTIONS SHOWN ARE FOR 2-STAGE GAS HEAT OPERATION. WHEN 1-STAGE OPERATION IS REQUIRED, WIRE 102B IS REMOVED, WIRES 21A, 101NN, AND 174A ARE NOT CONNECTED TO IGN, WIRE 123A IS NOT CONNECTED TO GV, AND WIRE 105C IS CONNECTED TO GV-M1 (NOT SHOWN).
10. WIRE TNS2-G/Y IS NOT PRESENT IF TNS2 IS AN AUTOTRANSFORMER.



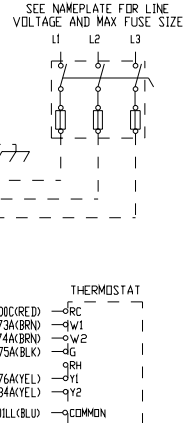
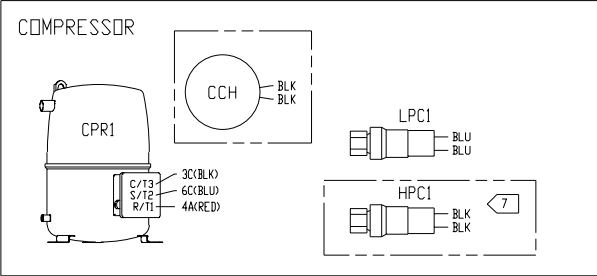
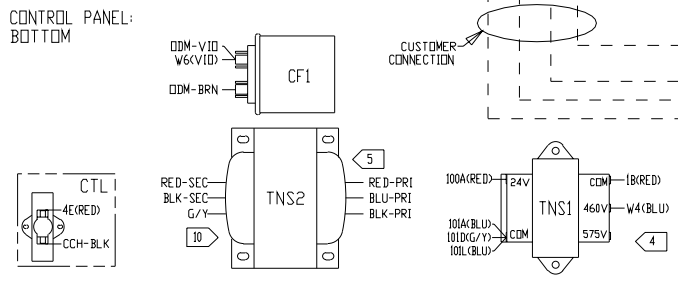
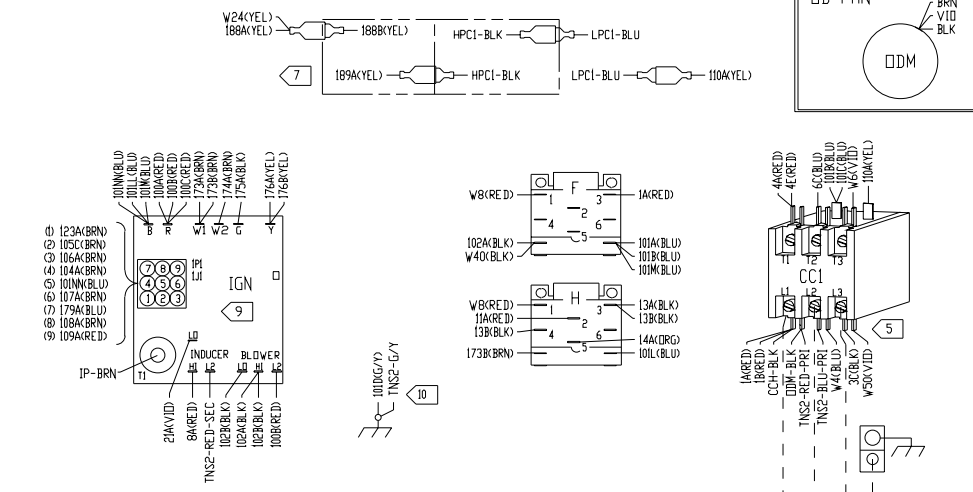
**⚠ WARNING**  
**HAZARDOUS VOLTAGE!**  
 DISCONNECT ALL ELECTRIC POWER, INCLUDING REMOTE DISCONNECTS, BEFORE SERVICING.  
 FAILURE TO DISCONNECT POWER BEFORE SERVICING CAN CAUSE SEVERE PERSONAL INJURY OR DEATH.

**⚠ AVERTISSEMENT**  
**VOLTAGE HASARDEUX!**  
 DECONNECTEZ TOUTES LES SOURCES ELECTRIQUES INCLUANT LES DISJONCTEURS SITUES A DISTANCE AVANT D'EFFECTUER L'ENTRETIEN.  
 FAUTE DE DECONNECTER LA SOURCE ELECTRIQUE AVANT D'EFFECTUER L'ENTRETIEN PEUT ENTRAÎNER DES BLESSURES CORPORELLES SEVERES OU LA MORT.

**⚠ CAUTION**  
 USE COPPER CONDUCTORS ONLY!  
 UNIT TERMINALS ARE NOT DESIGNED TO ACCEPT OTHER TYPES OF CONDUCTORS.  
 FAILURE TO DO SO MAY CAUSE DAMAGE TO THE EQUIPMENT.

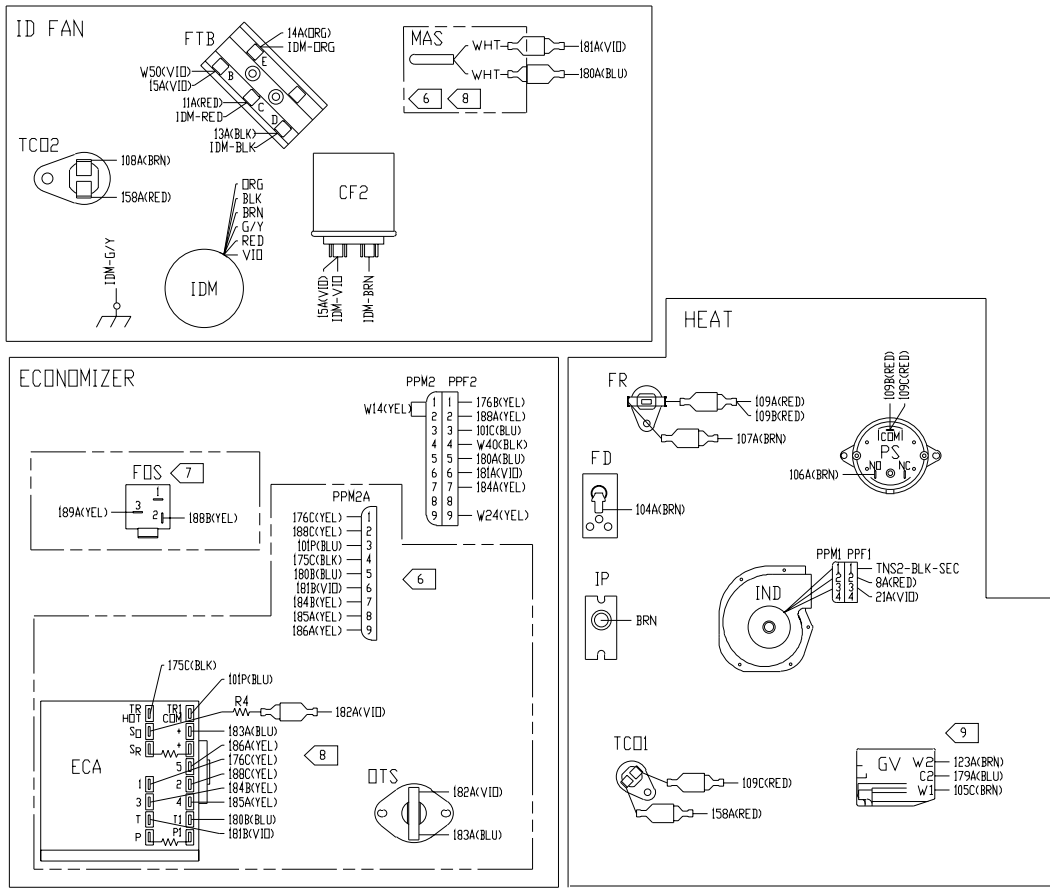
**IMPORTANT!**  
 DO NOT ENERGIZE UNIT UNTIL CHECK-OUT AND START-UP PROCEDURE HAS BEEN COMPLETED.

**CONTROL PANEL**



**Diagram 20**  
**Connection Diagram - 460-575v/60hz/3ph**  
**4 - 5 Ton Single Stage Gas Heat / Direct Drive**  
**4366-1517**

1. ALL WIRING AND DEVICES SHOWN DASHED TO BE SUPPLIED AND INSTALLED BY THE CUSTOMER IN ACCORDANCE WITH LOCAL AND NATIONAL ELECTRICAL CODES. PHANTOM LINE ENCLOSURES INDICATE ALTERNATE CIRCUITRY OR AVAILABLE SALES OPTIONS.
2. IF ANY OF THE ORIGINAL WIRE, AS SUPPLIED WITH THIS UNIT, MUST BE REPLACED, REPLACE WITH APPLIANCE WIRING MATERIAL RATED AT 105°C.
3. THREE PHASE MOTORS ARE PROTECTED UNDER PRIMARY SINGLE PHASING CONDITIONS. ALL MOTORS HAVE INTERNAL OVERLOAD PROTECTION. COMPRESSORS HAVE INTERNAL THERMAL PROTECTION.
4. CONNECTIONS SHOWN ARE FOR 460V/60HZ/3PH UNITS. WHEN 380V/60HZ/3PH OR 575V/60HZ/3PH OPERATION IS REQUIRED, MOVE WIRE W4(BLU) FROM THE 460V TERMINAL ON TNS1 TO THE 400V/575V TERMINAL.
5. CONNECTIONS SHOWN ARE FOR 380V/60HZ/3PH OR 460V/60HZ/3PH UNITS. WHEN 575V/60HZ/3PH OPERATION IS REQUIRED, REMOVE TNS2-BLU-PRI WIRE FROM CCI-L2 AND CONNECT TNS2-BLK-PRI WIRE TO CCI-L2.
6. WHEN INSTALLING ECONOMIZER, REMOVE PPM2 FROM PPF2, CONNECT PPM2A TO PPF2, AND CONNECT MAS TO WIRES 180A(BLU) AND 181A(VID).
7. CONNECTIONS SHOWN INCLUDE FDS AND HPCI. IF NEITHER OPTION IS INSTALLED, CONNECT WIRE LPCI-BLU TO WIRES W24(YEL)/188A(YEL). IF ONLY FDS IS INSTALLED, CONNECT WIRE 189A(YEL) TO WIRE LPCI-BLU. IF ONLY HPCI IS INSTALLED, CONNECT WIRE HPCI-BLK TO WIRES W24(YEL)/188A(YEL).
8. FOR MOTORIZED OUTSIDE AIR DAMPER, OPTIONAL MAS AND DTS (AND ASSOCIATED WIRING) ARE NOT USED, AND R4 IS REMOVED BETWEEN SO AND + DN ECA.
9. (FUTURE) CONNECTIONS SHOWN ARE FOR 2-STAGE GAS HEAT OPERATION. WHEN 1-STAGE OPERATION IS REQUIRED, WIRE 102B(BLK) IS REMOVED, WIRES 21A(VID), 101N(BLU), AND 174A(BRN) ARE NOT CONNECTED TO IGN. WIRE 123A(BRN) IS NOT CONNECTED TO GV, AND WIRE 105C(BRN) CONNECTS TO GV-M1 (NOT SHOWN).
10. WIRE TNS2-G/Y IS NOT PRESENT IF TNS2 IS AN AUTOTRANSFORMER.



**⚠ WARNING**

**HAZARDOUS VOLTAGE!**  
DISCONNECT ALL ELECTRIC POWER, INCLUDING REMOTE DISCONNECTS, BEFORE SERVICING.

FAILURE TO DISCONNECT POWER BEFORE SERVICING CAN CAUSE SEVERE PERSONAL INJURY OR DEATH.

**⚠ AVERTISSEMENT**

**VOLTAGE HASARDEUX!**  
DÉCONNECTEZ TOUTES LES SOURCES ÉLECTRIQUES INCLUANT LES DISJONCTEURS SITUÉS À DISTANCE AVANT D'EFFECTUER L'ENTRETIEN.

FAUTE DE DÉCONNECTER LA SOURCE ÉLECTRIQUE AVANT D'EFFECTUER L'ENTRETIEN PEUT ENTRAÎNER DES BLESSURES CORPORELLES SÉVÈRES OU LA MORT.

**⚠ CAUTION**

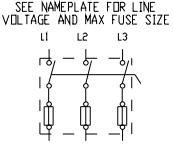
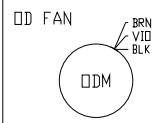
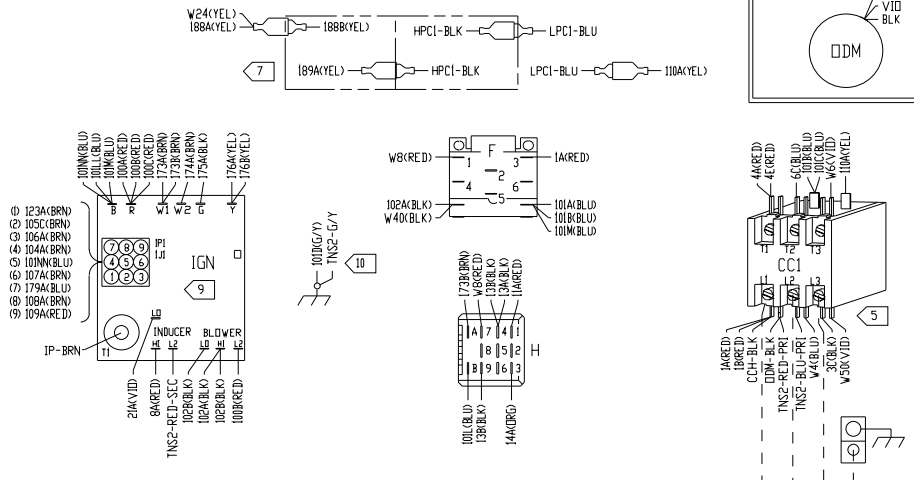
USE COPPER CONDUCTORS ONLY! UNIT TERMINALS ARE NOT DESIGNED TO ACCEPT OTHER TYPES OF CONDUCTORS.

FAILURE TO DO SO MAY CAUSE DAMAGE TO THE EQUIPMENT.

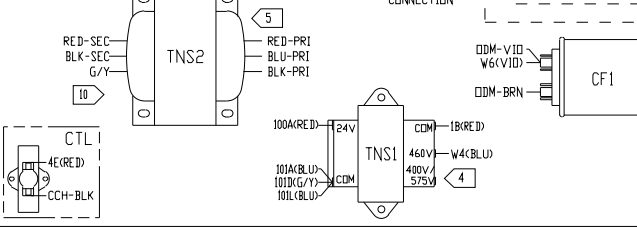
**IMPORTANT!**

DO NOT ENERGIZE UNIT UNTIL CHECK-OUT AND START-UP PROCEDURE HAS BEEN COMPLETED.

**CONTROL PANEL**



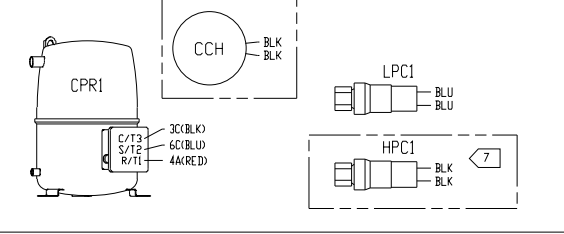
**CONTROL PANEL: BOTTOM**



**THERMOSTAT**

100C(RED)	<-RC
173A(BRN)	<-W1
174A(BRN)	<-W2
175A(BLK)	<-G
	<-RH
176A(YEL)	<-Y1
184A(YEL)	<-Y2
101L(BLU)	<-COMMON

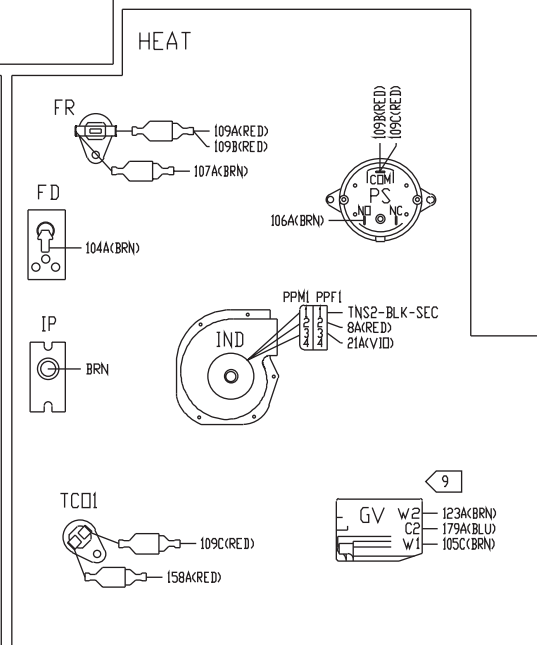
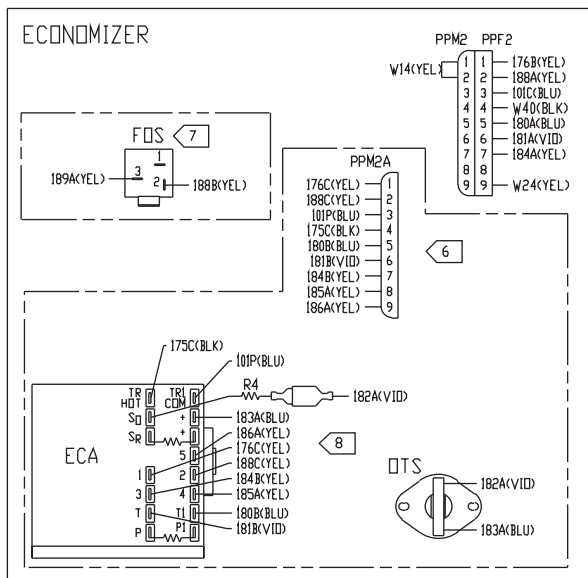
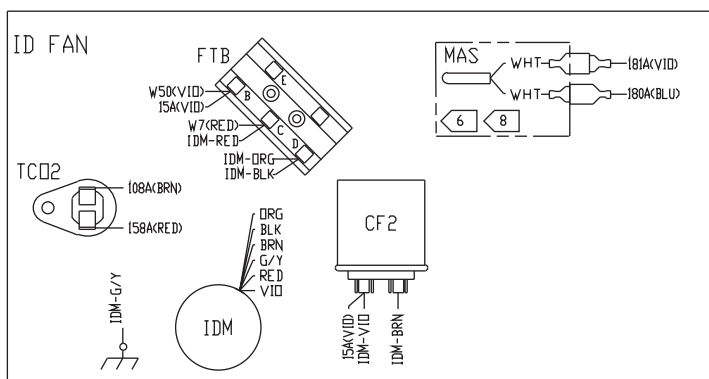
**COMPRESSOR**



4366-1517 J

**Diagram 21**  
**Connection Diagram - 460-575v/60hz/3ph**  
**4 - 5 Ton Single Stage Gas Heat / Oversize Motor**  
**4366-1526**

1. ALL WIRING AND DEVICES SHOWN DASHED TO BE SUPPLIED AND INSTALLED BY THE CUSTOMER IN ACCORDANCE WITH LOCAL AND NATIONAL ELECTRICAL CODES. PHANTOM LINE ENCLOSURES INDICATE ALTERNATE CIRCUITRY OR AVAILABLE SALES OPTIONS.
2. IF ANY OF THE ORIGINAL WIRE, AS SUPPLIED WITH THIS UNIT, MUST BE REPLACED, REPLACE WITH APPLIANCE WIRING MATERIAL RATED AT 105°C.
3. THREE PHASE MOTORS ARE PROTECTED UNDER PRIMARY SINGLE PHASING CONDITIONS. ALL MOTORS HAVE INTERNAL OVERLOAD PROTECTION. COMPRESSORS HAVE INTERNAL THERMAL PROTECTION.
4. CONNECTIONS SHOWN ARE FOR 460V/60HZ/3PH UNITS. WHEN 380V/60HZ/3PH OR 575V/60HZ/3PH OPERATION IS REQUIRED, MOVE WIRE W4(BLU) FROM THE 460V TERMINAL ON TNS1 TO THE 400V/575V TERMINAL.
5. CONNECTIONS SHOWN ARE FOR 380V/60HZ/3PH OR 460V/60HZ/3PH UNITS. WHEN 575V/60HZ/3PH OPERATION IS REQUIRED, REMOVE TNS2-BLU-PRI WIRE FROM CCI-L2 AND CONNECT TNS2-BLK-PRI WIRE TO CCI-L2.
6. WHEN INSTALLING ECONOMIZER, REMOVE PPM2 FROM PPF2 AND CONNECT PPM2A TO PPF2, AND CONNECT MAS TO WIRES 180A(BLU) AND 181A(VID).
7. CONNECTIONS SHOWN INCLUDE FDS AND HPCI. IF NEITHER OPTION IS INSTALLED, CONNECT WIRE LPC1-BLU TO WIRES W24/188A. IF ONLY FDS IS INSTALLED, CONNECT WIRE 189A TO WIRE LPC1-BLU. IF ONLY HPCI IS INSTALLED, CONNECT WIRE HPCI-BLK TO WIRES W24/188A.
8. FOR MOTORIZED OUTSIDE AIR DAMPER, OPTIONAL MAS AND OTS (AND ASSOCIATED WIRING) ARE NOT USED, AND R4 IS REMOVED BETWEEN SO AND + ON ECA.
9. (FUTURE OPTION) CONNECTIONS SHOWN ARE FOR 2-STAGE GAS HEAT OPERATION. WHEN 1-STAGE OPERATION IS REQUIRED, WIRE 102B IS REMOVED, WIRES 21A, 101NN, AND 174A ARE NOT CONNECTED TO IGN, WIRE 123A IS NOT CONNECTED TO GV, AND WIRE 105C IS CONNECTED TO GV-M1 (NOT SHOWN).



**⚠ WARNING**  
**HAZARDOUS VOLTAGE!**  
 DISCONNECT ALL ELECTRIC POWER, INCLUDING REMOTE DISCONNECTS, BEFORE SERVICING.

FAILURE TO DISCONNECT POWER BEFORE SERVICING CAN CAUSE SEVERE PERSONAL INJURY OR DEATH.

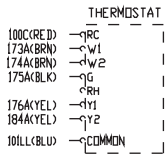
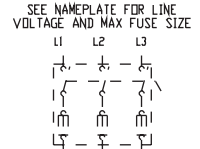
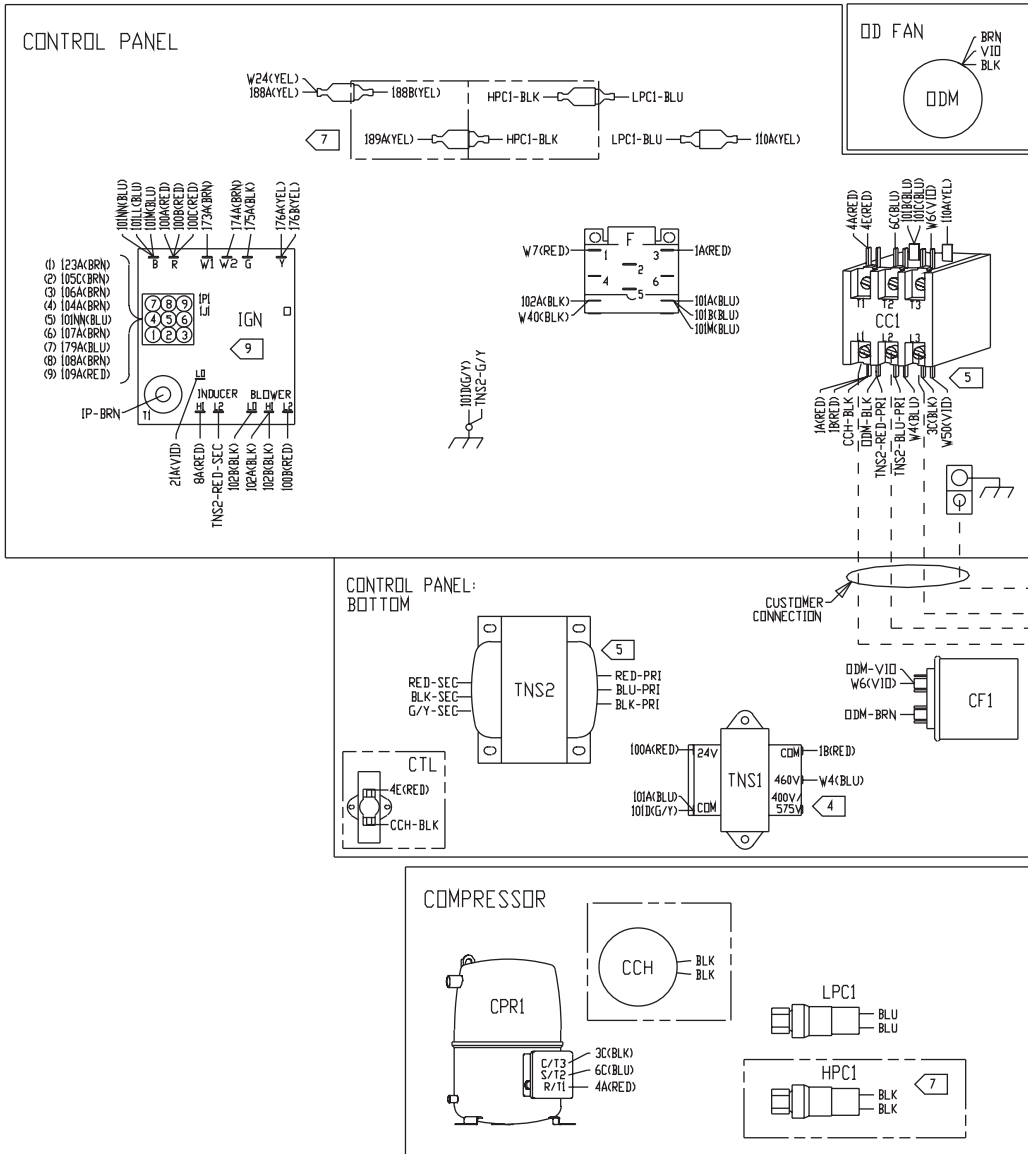
**⚠ AVERTISSEMENT**  
**VOLTAGE HASARDEUX!**  
 DECONNECTEZ TOUTES LES SOURCES ELECTRIQUES INCLUANT LES DISJONCTEURS SITUÉS A DISTANCE AVANT D'EFFECTUER L'ENTRETIEN.

FAUTE DE DECONNECTER LA SOURCE ELECTRIQUE AVANT D'EFFECTUER L'ENTRETIEN PEUT ENTRAÎNER DES BLESSURES CORPORELLES SEVERES OU LA MORT.

**⚠ CAUTION**  
**USE COPPER CONDUCTORS ONLY!**  
 UNIT TERMINALS ARE NOT DESIGNED TO ACCEPT OTHER TYPES OF CONDUCTORS.

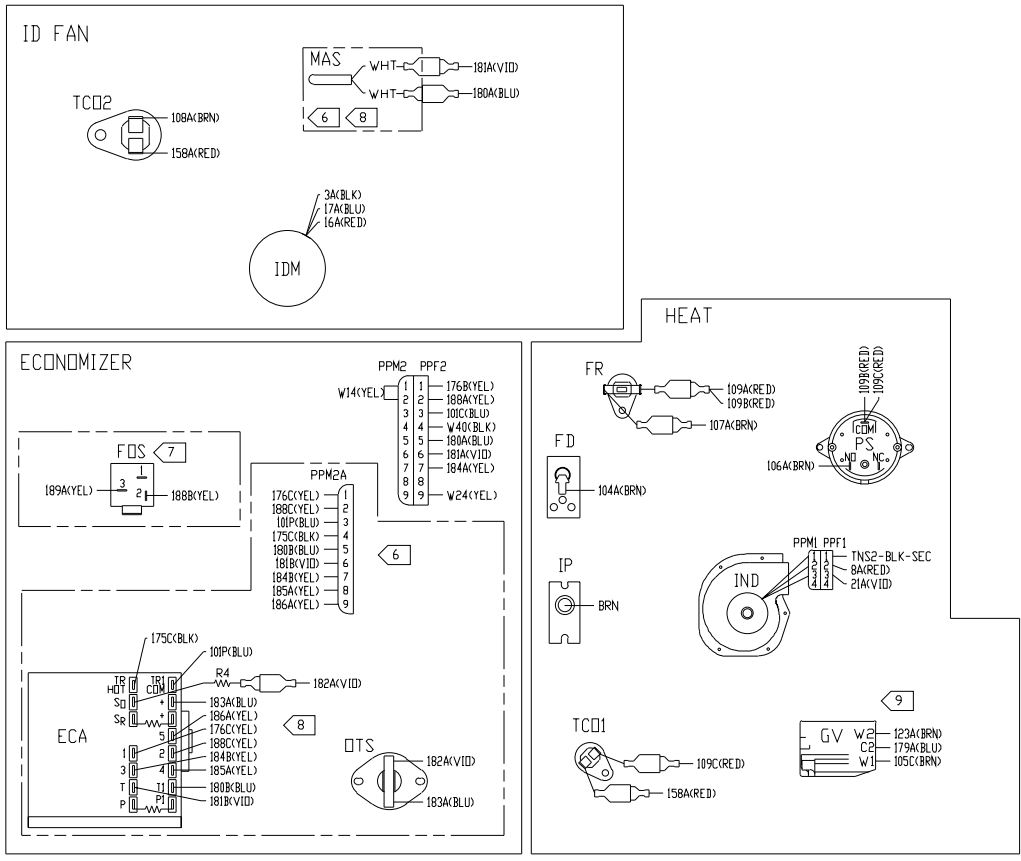
FAILURE TO DO SO MAY CAUSE DAMAGE TO THE EQUIPMENT.

**IMPORTANT!**  
 DO NOT ENERGIZE UNIT UNTIL CHECK-OUT AND START-UP PROCEDURE HAS BEEN COMPLETED.



**Diagram 22**  
**Connection Diagram - 460-575v/60hz/3ph**  
**Single Stage Gas Heat / Belt Drive**  
**4366-1523**

1. ALL WIRING AND DEVICES SHOWN DASHED TO BE SUPPLIED AND INSTALLED BY THE CUSTOMER IN ACCORDANCE WITH LOCAL AND NATIONAL ELECTRICAL CODES. PHANTOM LINE ENCLOSURES INDICATE ALTERNATE CIRCUITRY OR AVAILABLE SALES OPTIONS.
2. IF ANY OF THE ORIGINAL WIRE, AS SUPPLIED WITH THIS UNIT, MUST BE REPLACED, REPLACE WITH APPLIANCE WIRING MATERIAL RATED AT 105°C.
3. THREE PHASE MOTORS ARE PROTECTED UNDER PRIMARY SINGLE PHASING CONDITIONS. ALL MOTORS HAVE INTERNAL OVERLOAD PROTECTION. COMPRESSORS HAVE INTERNAL THERMAL PROTECTION.
4. CONNECTIONS SHOWN ARE FOR 460V/60HZ/3PH UNITS. WHEN 380V/60HZ/3PH OR 575V/60HZ/3PH OPERATION IS REQUIRED, MOVE WIRE W4(BLU) FROM THE 460V TERMINAL ON TNS1 TO THE 400V/575V TERMINAL.
5. CONNECTIONS SHOWN ARE FOR 380V/60HZ/3PH OR 460V/60HZ/3PH UNITS. WHEN 575V/60HZ/3PH OPERATION IS REQUIRED, REMOVE WIRE TNS2-BLU-PRI FROM CCI-L2 AND CONNECT WIRE TNS2-BLK-PRI TO CCI-L2.
6. WHEN INSTALLING ECONOMIZER, REMOVE PPM2 FROM PPF2, CONNECT PPM2A TO PPF2, AND CONNECT MAS TO WIRES 180A(BLU) AND 181A(VID).
7. CONNECTIONS SHOWN INCLUDE FDS AND HPCI. IF NEITHER OPTION IS INSTALLED, CONNECT WIRE LPC1-BLU TO WIRES W24(YEL)/188A(YEL). IF ONLY FDS IS INSTALLED, CONNECT WIRE 189A(YEL) TO WIRE LPC1-BLU. IF ONLY HPCI IS INSTALLED, CONNECT WIRE HPCI-BLK TO WIRES W24(YEL)/188A(YEL).
8. FOR MOTORIZED OUTSIDE AIR DAMPER, OPTIONAL MAS AND DTS (AND ASSOCIATED WIRING) ARE NOT USED, AND R4 IS REMOVED BETWEEN SO AND + ON ECA.
9. (FUTURE) CONNECTIONS SHOWN ARE FOR 2-STAGE GAS HEAT OPERATION. WHEN 1-STAGE OPERATION IS REQUIRED, WIRE 102B(BLK) IS REMOVED, WIRES 21A(VID), 101N(BLU), AND 174A(BRN) ARE NOT CONNECTED TO IGN, WIRE 123A(BRN) IS NOT CONNECTED TO GV, AND WIRE 105C(BRN) IS CONNECTED TO GV-M1 (NOT SHOWN).
10. WIRE TNS2-G/Y IS NOT PRESENT IF TNS2 IS AN AUTOTRANSFORMER.





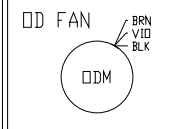
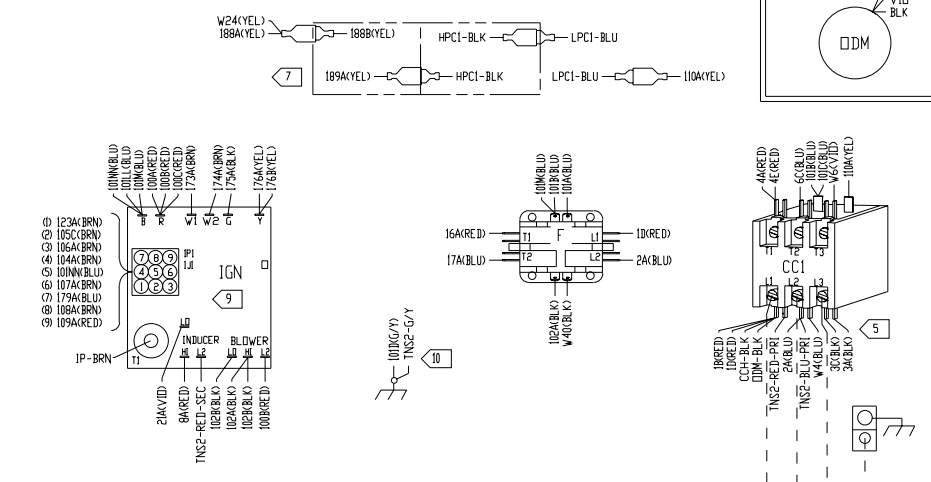
**⚠ WARNING**  
**HAZARDOUS VOLTAGE!**  
 DISCONNECT ALL ELECTRIC POWER, INCLUDING REMOTE DISCONNECTS, BEFORE SERVICING.  
 FAILURE TO DISCONNECT POWER BEFORE SERVICING CAN CAUSE SEVERE PERSONAL INJURY OR DEATH.

**⚠ AVERTISSEMENT**  
**VOLTAGE HASARDEUX!**  
 DECONNECTEZ TOUTES LES SOURCES ELECTRIQUES INCLUANT LES DISJONCTEURS SITUÉS A DISTANCE AVANT D'EFFECTUER L'ENTRETIEN.  
 FAUTE DE DECONNECTER LA SOURCE ELECTRIQUE AVANT D'EFFECTUER L'ENTRETIEN PEUT ENTRAINER DES BLESSURES CORPORELLES SEVERES OU LA MORT.

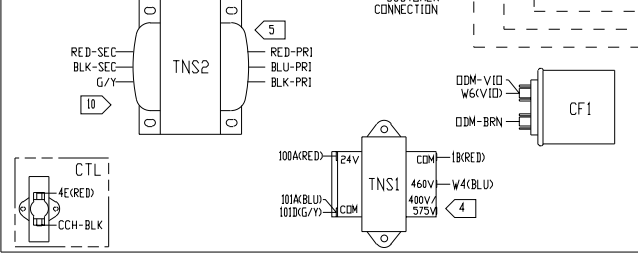
**⚠ CAUTION**  
 USE COPPER CONDUCTORS ONLY!  
 UNIT TERMINALS ARE NOT DESIGNED TO ACCEPT OTHER TYPES OF CONDUCTORS.  
 FAILURE TO DO SO MAY CAUSE DAMAGE TO THE EQUIPMENT.

**IMPORTANT!**  
 DO NOT ENERGIZE UNIT UNTIL CHECK-OUT AND START-UP PROCEDURE HAS BEEN COMPLETED.

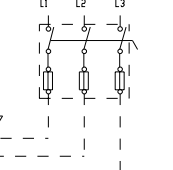
**CONTROL PANEL**



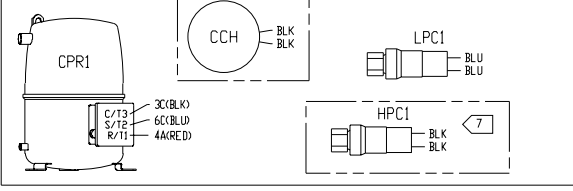
**CONTROL PANEL: BOTTOM**



SEE NAMEPLATE FOR LINE VOLTAGE AND MAX FUSE SIZE



**COMPRESSOR**



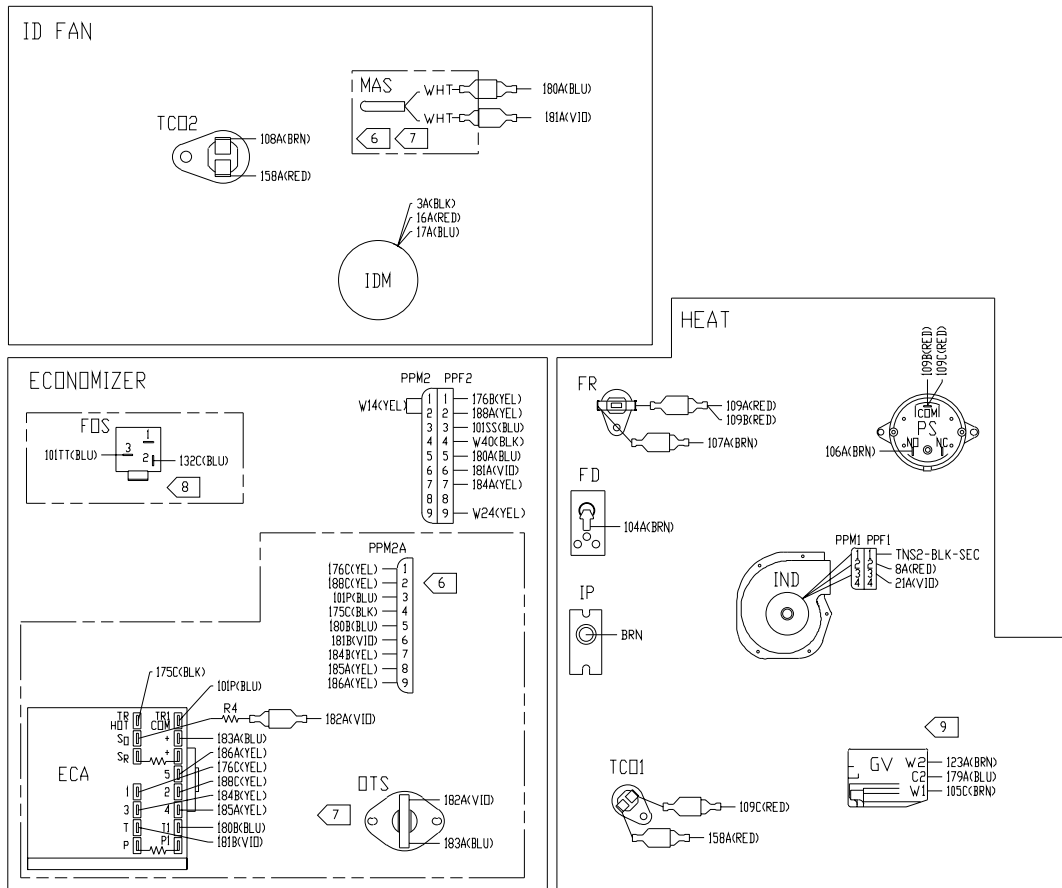
**THERMOSTAT**

100C(RED)	-RC
173A(BRN)	-W1
174A(BRN)	-W2
175A(BLK)	-G
176A(YEL)	-RH
184A(YEL)	-Y1
184A(YEL)	-Y2
101LL(BLU)	-COMMON

4366-1523 K

**Diagram 23**  
**Connection Diagram - 460-575v/60hz/3ph**  
**6 - 7.5 Ton Gas Heat / Single Compressor**  
**4366-1538**

1. ALL WIRING AND DEVICES SHOWN DASHED TO BE SUPPLIED AND INSTALLED BY THE CUSTOMER IN ACCORDANCE WITH LOCAL AND NATIONAL ELECTRICAL CODES. PHANTOM LINE ENCLOSURES INDICATE ALTERNATE CIRCUITRY OR AVAILABLE SALES OPTIONS.
2. IF ANY OF THE ORIGINAL WIRE, AS SUPPLIED WITH THIS UNIT, MUST BE REPLACED, REPLACE WITH APPLIANCE WIRING MATERIAL RATED AT 105°C.
3. THREE PHASE MOTORS ARE PROTECTED UNDER PRIMARY SINGLE PHASING CONDITIONS. ALL MOTORS HAVE INTERNAL OVERLOAD PROTECTION. COMPRESSORS HAVE INTERNAL THERMAL PROTECTION.
4. CONNECTIONS SHOWN ARE FOR 460V/60HZ/3PH UNITS. WHEN 380V/60HZ/3PH OR 575V/60HZ/3PH OPERATION IS REQUIRED, MOVE WIRE W4(BLU) FROM THE 460V TERMINAL ON TNS1 TO THE 400V/575V TERMINAL.
5. CONNECTIONS SHOWN ARE FOR 380V/60HZ/3PH OR 460V/60HZ/3PH UNITS. WHEN 575V/60HZ/3PH OPERATION IS REQUIRED, REMOVE WIRE TNS2-BLU-PRI FROM CCI-L2 AND CONNECT WIRE TNS2-BLK-PRI TO CCI-L2.
6. WHEN INSTALLING ECONOMIZER, REMOVE PPM2 FROM PPF2, CONNECT PPM2A TO PPF2, AND CONNECT MAS TO WIRES 180A(BLU) AND 181A(VID).
7. FOR MOTORIZED OUTSIDE AIR DAMPER, OPTIONAL MAS AND OTS (AND ASSOCIATED WIRING) ARE NOT USED, AND R4 IS REMOVED BETWEEN S0 AND + DN ECA.
8. CONNECTIONS SHOW OPTIONAL FDS INSTALLED. IF FDS IS NOT INSTALLED, CONNECT WIRE W27(BLU) TO WIRE 132A(BLU).
9. CONNECTIONS SHOWN ARE FOR 2-STAGE GAS HEAT OPERATION. WHEN 1-STAGE OPERATION IS REQUIRED, WIRE 102B(BLK) IS REMOVED, WIRES 21A(VID), 101N(BLU), AND 174A(BRN) ARE NOT CONNECTED TO IGN, WIRE 123A(BRN) IS NOT CONNECTED TO GV, AND WIRE 105C(BRN) IS CONNECTED TO GV-MI (NOT SHOWN).
10. WIRE TNS2-G/Y IS NOT PRESENT IF TNS2 IS AN AUTOTRANSFORMER.

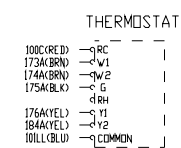
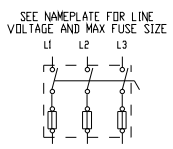
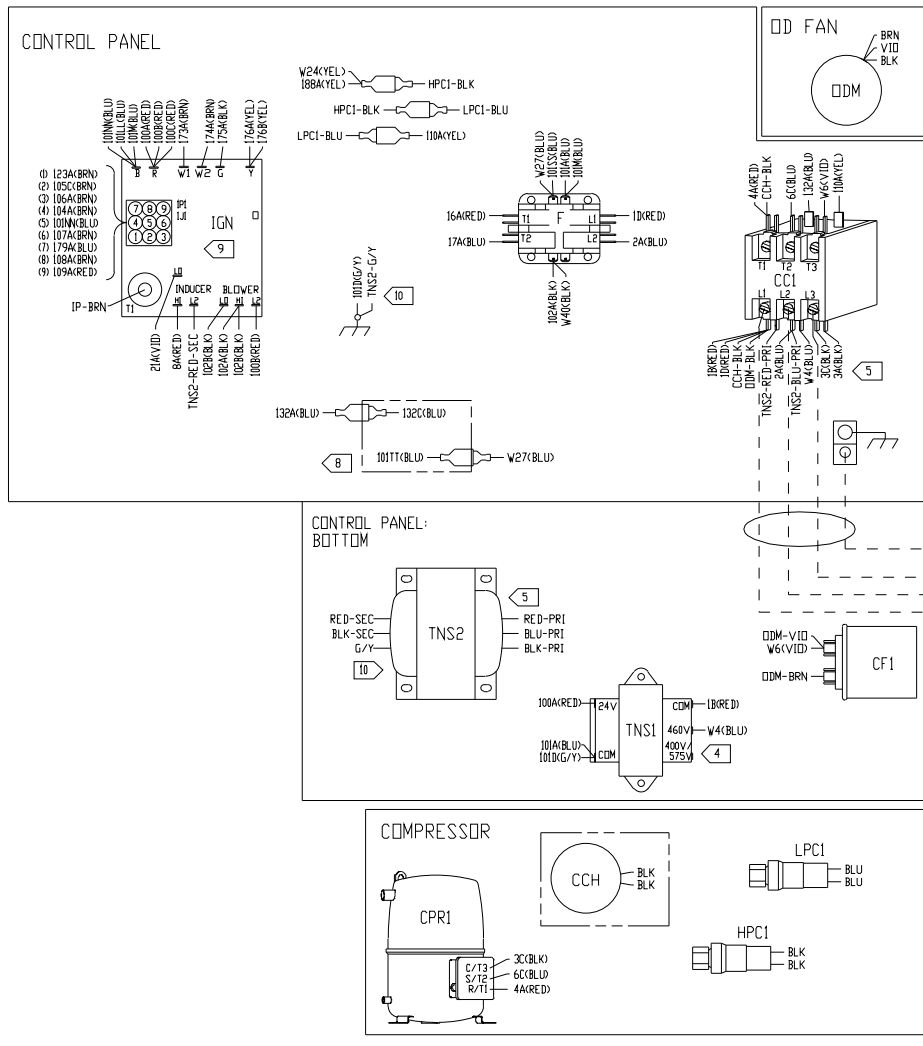


**⚠ WARNING**  
**HAZARDOUS VOLTAGE!**  
 DISCONNECT ALL ELECTRIC POWER, INCLUDING REMOTE DISCONNECTS, BEFORE SERVICING.  
 FAILURE TO DISCONNECT POWER BEFORE SERVICING CAN CAUSE SEVERE PERSONAL INJURY OR DEATH.

**⚠ AVERTISSEMENT**  
**VOLTAGE HASARDEUX!**  
 DECONNECTEZ TOUTES LES SOURCES ELECTRIQUES INCLUANT LES DISJONCTEURS SITUÉS À DISTANCE AVANT D'EFFECTUER L'ENTRETIEN.  
 FAUTE DE DECONNECTER LA SOURCE ELECTRIQUE AVANT D'EFFECTUER L'ENTRETIEN PEUT ENTRAINER DES BLESSURES CORPORELLES SEVERES OU LA MORT.

**⚠ CAUTION**  
 USE COPPER CONDUCTORS ONLY!  
 UNIT TERMINALS ARE NOT DESIGNED TO ACCEPT OTHER TYPES OF CONDUCTORS.  
 FAILURE TO DO SO MAY CAUSE DAMAGE TO THE EQUIPMENT.

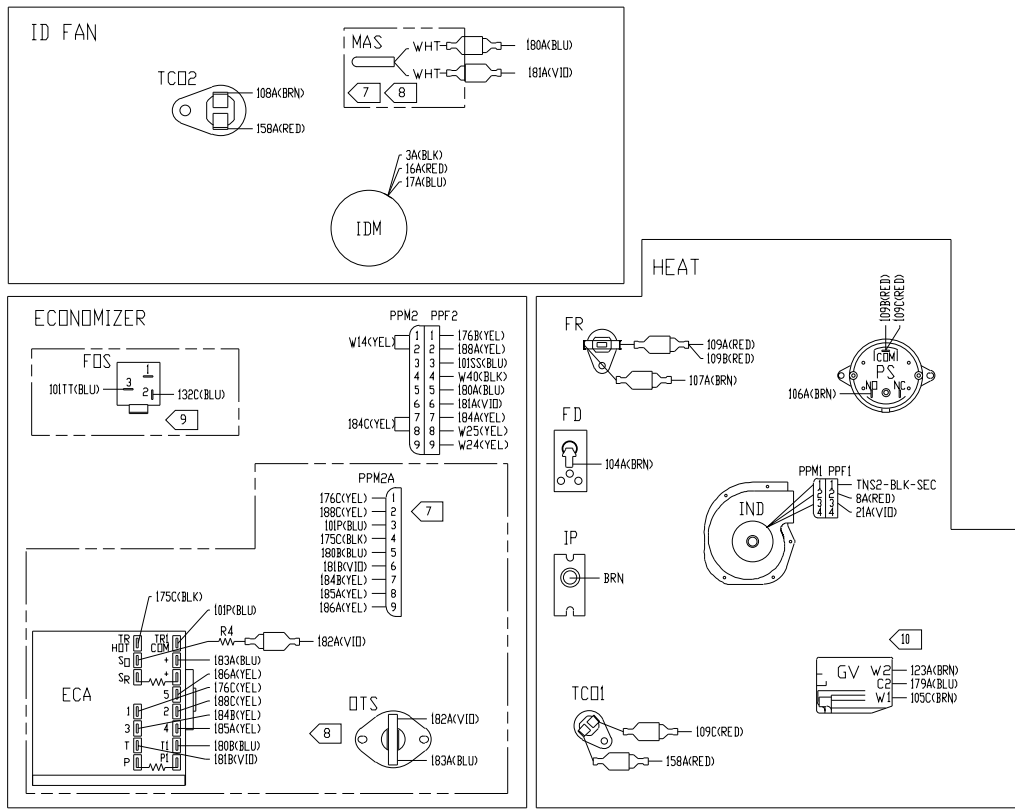
**IMPORTANT!**  
 DO NOT ENERGIZE UNIT UNTIL CHECK-OUT AND START-UP PROCEDURE HAS BEEN COMPLETED.



4366-1538 F

**Diagram 24**  
**Connection Diagram - 460-575v/60hz/3ph**  
**7.5 - 10 Ton Gas Heat / Dual Compressor**  
**4366-1531**

1. ALL WIRING AND DEVICES SHOWN DASHED TO BE SUPPLIED AND INSTALLED BY THE CUSTOMER IN ACCORDANCE WITH LOCAL AND NATIONAL ELECTRICAL CODES. PHANTOM LINE ENCLOSURES INDICATE ALTERNATE CIRCUITRY OR AVAILABLE SALES OPTIONS.
2. IF ANY OF THE ORIGINAL WIRE, AS SUPPLIED WITH THIS UNIT, MUST BE REPLACED, REPLACE WITH APPLIANCE WIRING MATERIAL RATED AT 105°C.
3. THREE PHASE MOTORS ARE PROTECTED UNDER PRIMARY SINGLE PHASING CONDITIONS. ALL MOTORS HAVE INTERNAL OVERLOAD PROTECTION. COMPRESSORS HAVE INTERNAL THERMAL PROTECTION.
4. CONNECTIONS SHOWN ARE FOR 460V/60HZ/3PH UNITS. WHEN 380V/60HZ/3PH OR 575V/60HZ/3PH OPERATION IS REQUIRED, MOVE WIRE W4(BLU) FROM THE 460V TERMINAL ON TNS1 TO THE 400V/575V TERMINAL.
5. CONNECTIONS SHOWN ARE FOR 380V/60HZ/3PH OR 460V/60HZ/3PH UNITS. WHEN 575V/60HZ/3PH OPERATION IS REQUIRED, REMOVE WIRE TNS2-BLU-PRI FROM CCI-L2 AND CONNECT WIRE TNS2-BLK-PRI TO CCI-L2.
6. CCH2 CONDUCTORS ARE IDENTIFIED BY BROWN TAPE PLACED NEAR WIRE TERMINATIONS INSIDE CONTROL PANEL.
7. WHEN INSTALLING ECONOMIZER, REMOVE PPM2 FROM PPF2, CONNECT PPM2A TO PPF2, AND CONNECT MAS TO WIRES 180A(BLU) AND 181A(VID).
8. FOR MOTORIZED OUTSIDE AIR DAMPER, OPTIONAL MAS AND ODS (AND ASSOCIATED WIRING) ARE NOT USED, AND R4 IS REMOVED BETWEEN SO AND + ON ECA.
9. CONNECTIONS SHOW OPTIONAL FDS INSTALLED. IF FDS IS NOT INSTALLED, CONNECT WIRE W27(BLU) TO WIRE 132A(BLU).
10. CONNECTIONS SHOWN ARE FOR 2-STAGE GAS HEAT OPERATION. WHEN 1-STAGE OPERATION IS REQUIRED, WIRE 102B(BLK) IS REMOVED, WIRES 21A(VID), 101N(BLU), AND 174A(BRN) ARE NOT CONNECTED TO IGN, WIRE 123A(BRN) IS NOT CONNECTED TO GV, AND WIRE 105C(BRN) IS CONNECTED TO GV-M (NOT SHOWN).
11. WIRE TNS2-G/Y IS NOT PRESENT IF TNS2 IS AN AUTOTRANSFORMER.



**⚠ WARNING**  
**HAZARDOUS VOLTAGE!**  
 DISCONNECT ALL ELECTRIC POWER,  
 INCLUDING REMOTE DISCONNECTS,  
 BEFORE SERVICING.

FAILURE TO DISCONNECT POWER  
 BEFORE SERVICING CAN CAUSE  
 SEVERE PERSONAL INJURY OR  
 DEATH.

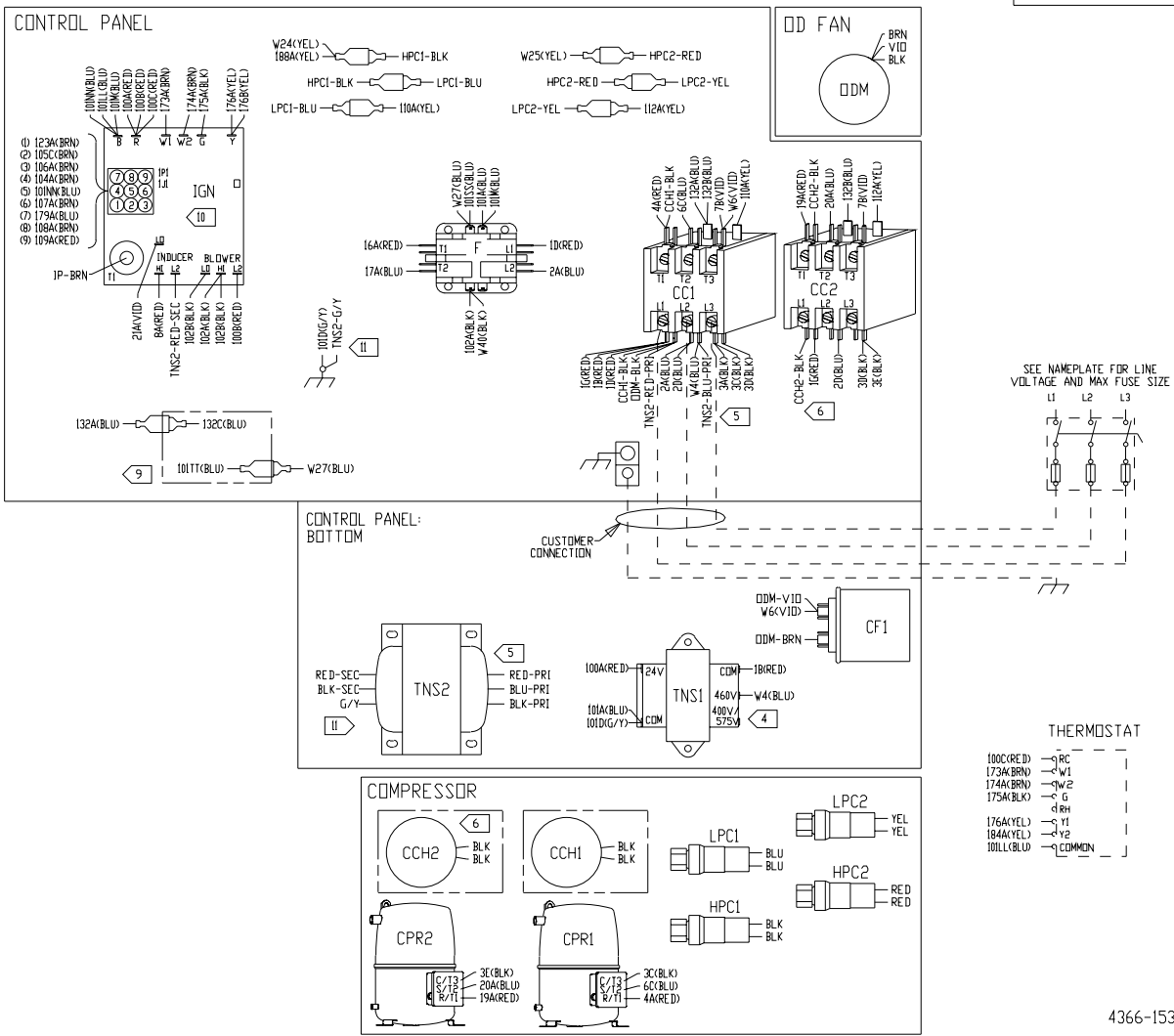
**⚠ AVERTISSEMENT**  
**VOLTAGE HASARDEUX!**  
 DECONNECTEZ TOUTES LES SOURCES  
 ELECTRIQUES INCLUANT LES DISJONCTEURS  
 SITUES A DISTANCE AVANT D'EFFECTUER  
 L'ENTRETIEN.

FAUTE DE DECONNECTER LA SOURCE  
 ELECTRIQUE AVANT D'EFFECTUER  
 L'ENTRETIEN PEUT ENTRAÎNER DES BLESSURES  
 CORPORELLES SEVERES OU LA MORT.

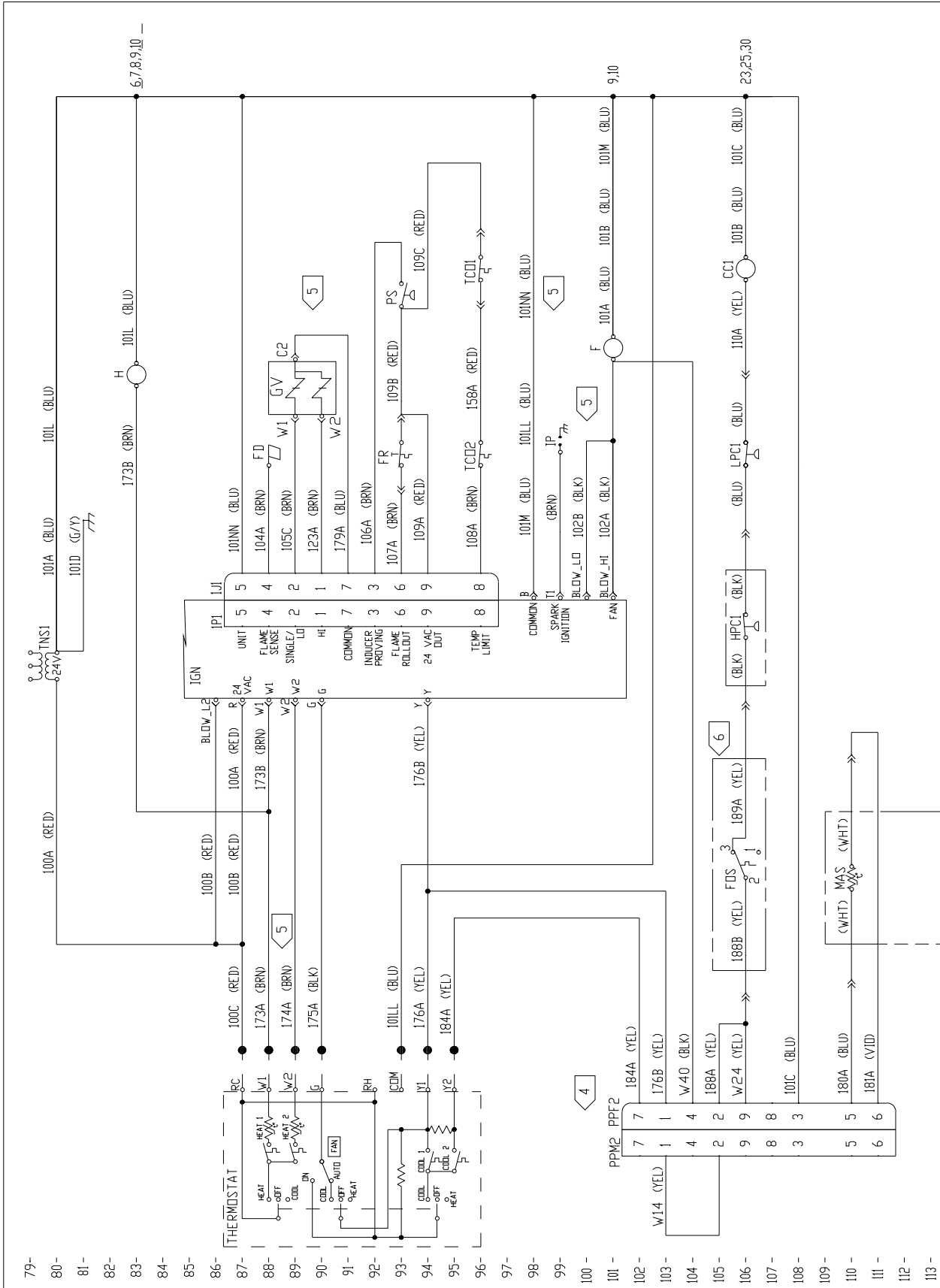
**⚠ CAUTION**  
 USE COPPER CONDUCTORS ONLY!  
 UNIT TERMINALS ARE NOT DESIGNED  
 TO ACCEPT OTHER TYPES OF  
 CONDUCTORS.

FAILURE TO DO SO MAY CAUSE  
 DAMAGE TO THE EQUIPMENT.

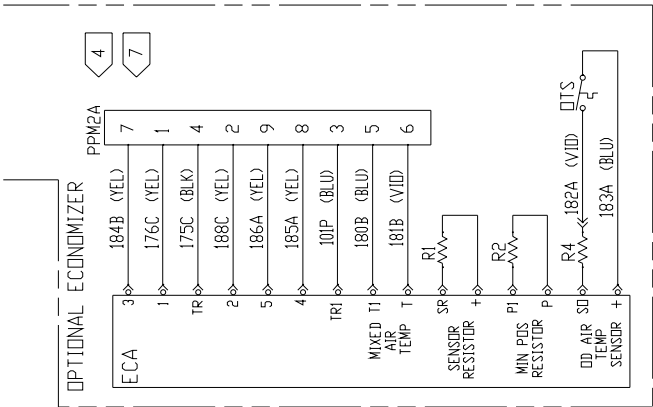
**IMPORTANT!**  
 DO NOT ENERGIZE UNIT  
 UNTIL CHECK-OUT AND  
 START-UP PROCEDURE HAS  
 BEEN COMPLETED.



**Diagram 25**  
**Control Schematic -**  
**Single Stage Gas Heat / Direct Drive**  
**4366-1001**



113 -  
114 -  
115 -  
116 -  
117 -  
118 -  
119 -  
120 -  
121 -  
122 -  
123 -  
124 -  
125 -  
126 -  
127 -  
128 -  
129 -  
130 -  
131 -  
132 -  
133 -  
134 -  
135 -  
136 -  
137 -  
138 -  
139 -  
140 -  
141 -  
142 -  
143 -  
144 -  
145 -  
146 -  
147 -  
148 -  
149 -

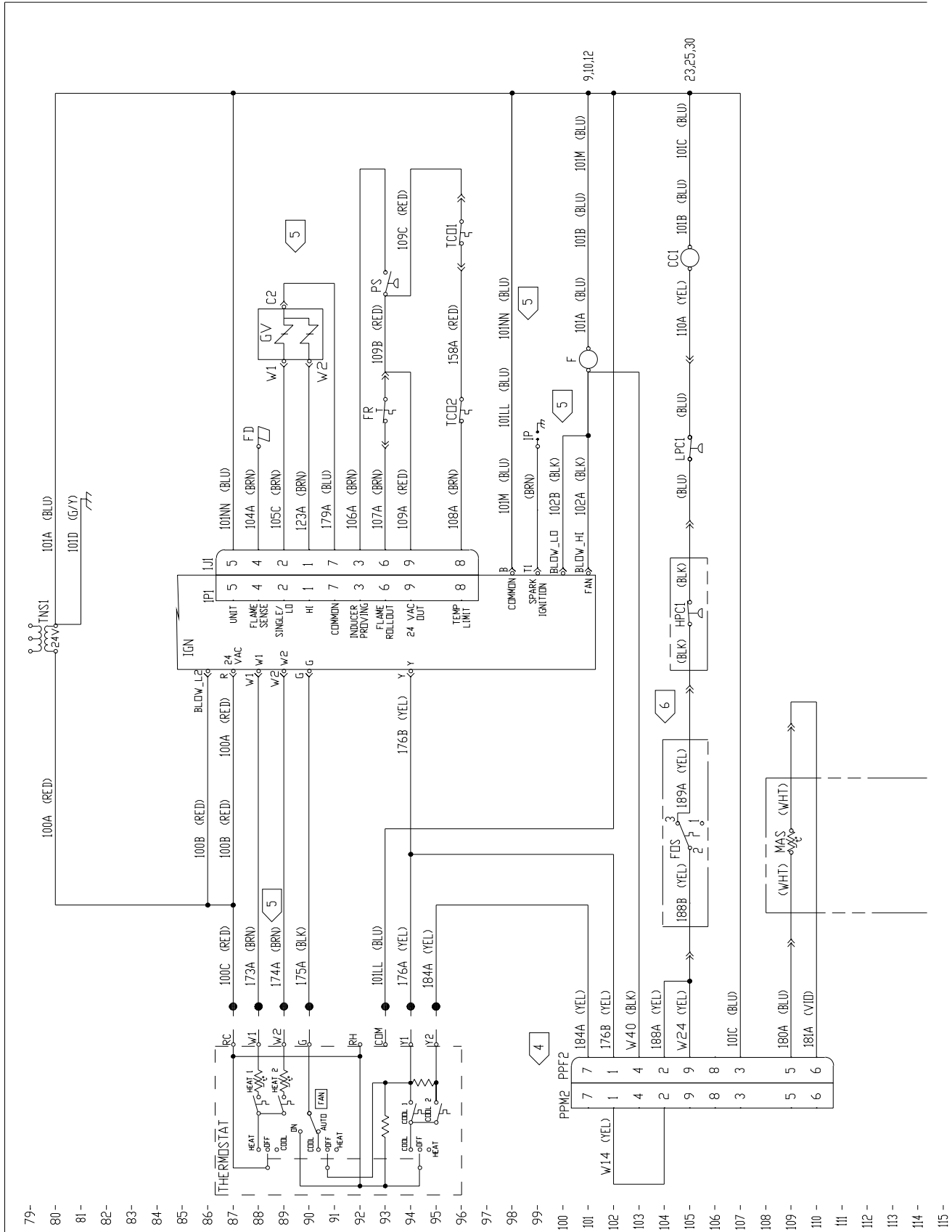


1. UNLESS OTHERWISE NOTED, ALL SWITCHES ARE SHOWN AT 25° C (77° F) AT ATMOSPHERIC PRESSURE, AT 50% RELATIVE HUMIDITY WITH ALL UTILITIES TURNED OFF AND AFTER A NORMAL SHUTDOWN HAS OCCURRED.
2. DASHED LINES INDICATE RECOMMENDED FIELD WIRING BY OTHERS. DASHED LINE ENCLOSURES AND/OR DASHED DEVICE OUTLINES INDICATE COMPONENTS PROVIDED BY THE FIELD. PHANTOM LINE ENCLOSURES INDICATE ALTERNATE CIRCUITRY OR AVAILABLE SALES OPTIONS.
3. NUMBERS ALONG THE RIGHT SIDE OF THE SCHEMATIC DESIGNATE THE LOCATION OF CONTACTS BY LINE NUMBER. AN UNDERLINED NUMBER INDICATES A NORMALLY CLOSED CONTACT.
4. WHEN INSTALLING OPTIONAL ECONOMIZER, REMOVE CONFIG PLUG PPM2, AND CONNECT ECONOMIZER PLUG PPM2A TO PPF2, AND CONNECT MAS TO WIRES 180A AND 181A.
5. (FUTURE) CONNECTIONS SHOWN ARE FOR 2-STAGE GAS HEAT OPERATION. WHEN 1-STAGE OPERATION IS REQUIRED, WIRE 102B IS REMOVED, WIRES 101NN AND 174A ARE NOT CONNECTED TO IGN, WIRE 123A IS NOT CONNECTED TO GV, AND WIRE 105C IS CONNECTED TO GV-MI.
6. CONNECTIONS SHOWN INCLUDE FDS AND HPCI. IF NEITHER OPTION IS INSTALLED, CONNECT WIRE LPC1-BLU TO WIRES W24/188A. IF ONLY FDS IS INSTALLED, CONNECT WIRE 189A TO WIRE LPC1-BLU. IF ONLY HPCI IS INSTALLED, CONNECT WIRE HPCI-BLK TO WIRES W24/188A.
7. FOR MOTORIZED OUTSIDE AIR DAMPER, OPTIONAL MAS AND DTS (AND ASSOCIATED WIRING) ARE NOT USED, AND R4 IS REMOVED BETWEEN S0 AND +.

REF	DESCRIPTION	LINE
CCI	COMPRESSOR CONTACTOR	106
ECA	ECONOMIZER ACTUATOR	117-131
F	FAN RELAY	101
FD	FLAME DETECTOR	88
FDS	FROST/TAI	106
FR	FLAME ROLLOUT	93
GV	GAS VALVE	89-90
H	HEAT RELAY	83
HPCI	HIGH PRESSURE CUTOUT	106
IGN	IGNITION MODULE	86-101
IP	IGNITER	99
LPC1	LOW PRESSURE CUTOUT	106
MAS	MIXED AIR SENSOR	110
DTS	DD-AIR TEMP SWITCH	130
PS	PRESSURE SWITCH	93
R1	RESISTOR 750 OHM (RED)	126
R2	RESISTOR 130 OHM (GRN)	128
R4	RESISTOR 620 OHM (WHT)	130
TC01	TEMPERATURE LIMIT SWITCH	96
TC02	TEMPERATURE LIMIT SWITCH	96
TNS1	LOW VOLTAGE TRANSFORMER	80

COLOR	ABBR	COLOR	ABBR
BLACK	BLK	ORANGE	ORG
BLUE	BLU	RED	RED
BROWN	BRN	VIOLET (PURPLE)	VIO
GRAY (SLATE)	GRA	WHITE	WHT
GREEN/YELLOW	G/Y	YELLOW	YEL

**Diagram 26**  
**Control Schematic -**  
**2 - 5 Ton Single Stage Gas Heat / Belt Drive or Oversize Motor**  
**4366-1027**





114 -

115 -

116 -

117 -

118 -

119 -

120 -

121 -

122 -

123 -

124 -

125 -

126 -

127 -

128 -

129 -

130 -

131 -

132 -

133 -

134 -

135 -

136 -

137 -

138 -

139 -

140 -

141 -

142 -

143 -

144 -

145 -

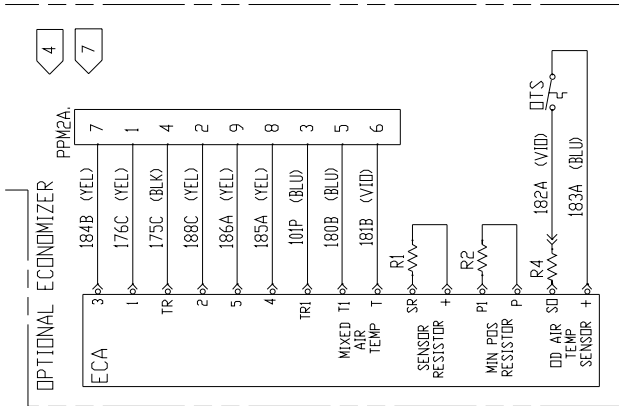
146 -

147 -

148 -

149 -

150 -



1. UNLESS OTHERWISE NOTED, ALL SWITCHES ARE SHOWN AT 25° C (77° F) AT ATMOSPHERIC PRESSURE, AT 50% RELATIVE HUMIDITY WITH ALL UTILITIES TURNED OFF AND AFTER A NORMAL SHUTDOWN HAS OCCURRED.

2. DASHED LINES INDICATE RECOMMENDED FIELD WIRING BY OTHERS. DASHED LINE ENCLOSURES AND/OR DASHED DEVICE OUTLINES INDICATE COMPONENTS PROVIDED BY THE FIELD. PHANTOM LINE ENCLOSURES INDICATE ALTERNATE CIRCUITRY OR AVAILABLE SALES OPTIONS.

3. NUMBERS ALONG THE RIGHT SIDE OF THE SCHEMATIC DESIGNATE THE LOCATION OF CONTACTS BY LINE NUMBER. AN UNDERLINED NUMBER INDICATES A NORMALLY CLOSED CONTACT.

4. WHEN INSTALLING OPTIONAL ECONOMIZER, REMOVE CONFIG PLUG PPM2, AND CONNECT ECONOMIZER PLUG PPM2A TO PPF2, AND CONNECT MAS TO WIRES 180A AND 181A.

5. (FUTURE) CONNECTIONS SHOWN ARE FOR 2-STAGE GAS HEAT OPERATION. WHEN 1-STAGE OPERATION IS REQUIRED, WIRE 102B IS REMOVED, WIRES 101N AND 174A ARE NOT CONNECTED TO IGN, WIRE 123A IS NOT CONNECTED TO GV, AND WIRE 105C IS CONNECTED TO GV-M.

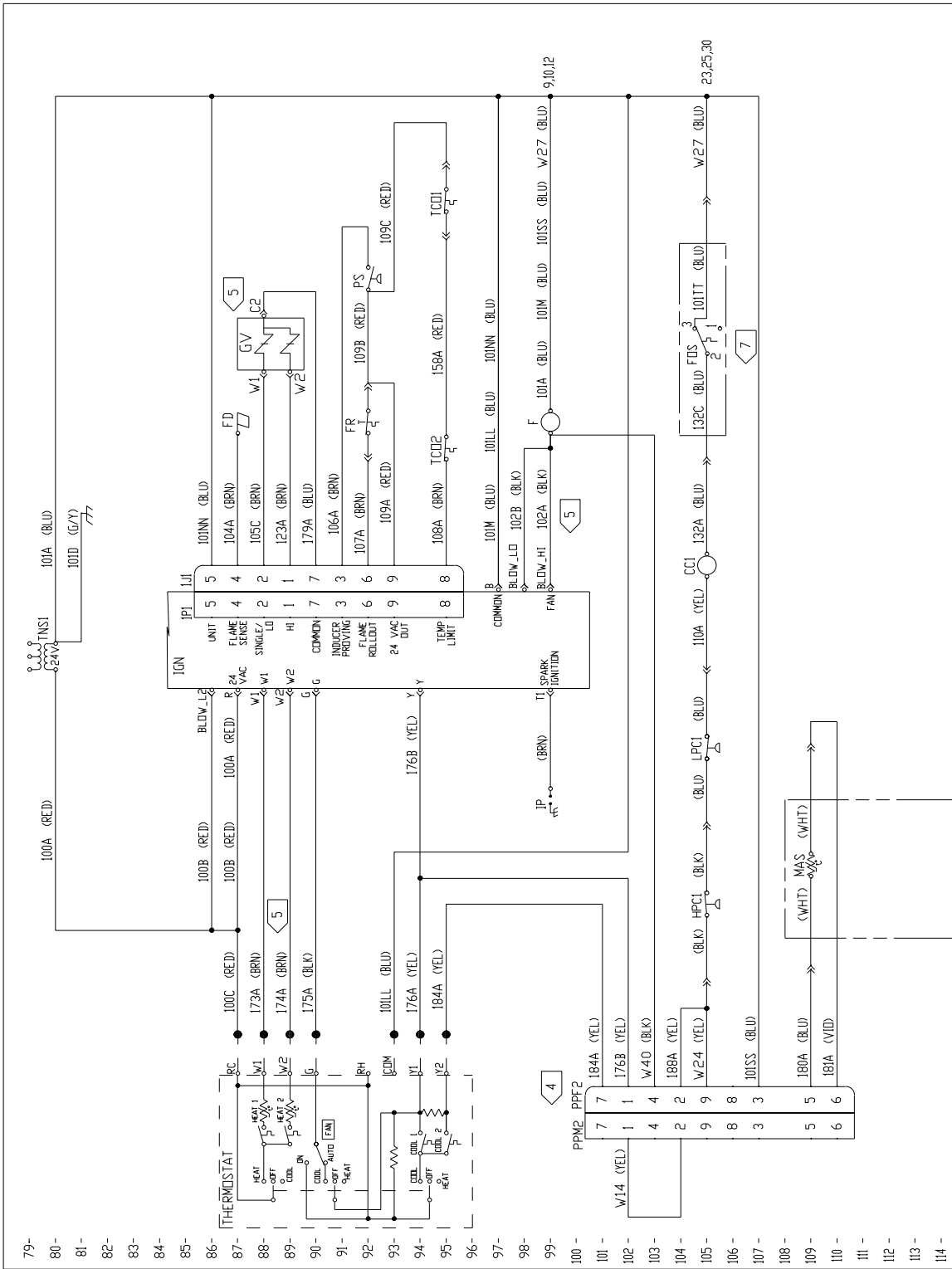
6. CONNECTIONS SHOWN INCLUDE FDS AND HPCI. IF NEITHER OPTION IS INSTALLED, CONNECT WIRE LPC1-BLU TO WIRES W24/188A. IF ONLY FDS IS INSTALLED, CONNECT WIRE 189A TO WIRE LPC1-BLU. IF ONLY HPCI IS INSTALLED, CONNECT WIRE HPCI-BLK TO WIRES W24/188A.

7. FOR MOTORIZED OUTSIDE AIR DAMPER, OPTIONAL MAS AND DTS (AND ASSOCIATED WIRING) ARE NOT USED, AND R4 IS REMOVED BETWEEN S0 AND +.

REF	DESCRIPTION	LINE
CC1	COMPRESSOR CONTACTOR	105
ECA	ECONOMIZER ACTUATOR	117-131
F	FAN RELAY	101
FD	FLAME DETECTOR	88
FDS	FROSTAT	105
FR	FLAME ROLLOUT	93
GV	GAS VALVE	89-90
HPCI	HIGH PRESSURE CUTOUT	105
IGN	IGNITION MODULE	86-100
IP	IGNITER	99
LPC1	LOW PRESSURE CUTOUT	105
MAS	MIXED AIR SENSOR	109
DTS	DD AIR TEMP SWITCH	130
PS	PRESSURE SWITCH	93
R1	RESISTOR 750 OHM (RED)	126
R2	RESISTOR 130 OHM (GRN)	128
R4	RESISTOR 620 OHM (WHT)	130
TCO1	TEMPERATURE LIMIT SWITCH	96
TCO2	TEMPERATURE LIMIT SWITCH	96
TNS1	LOW VOLTAGE TRANSFORMER	80

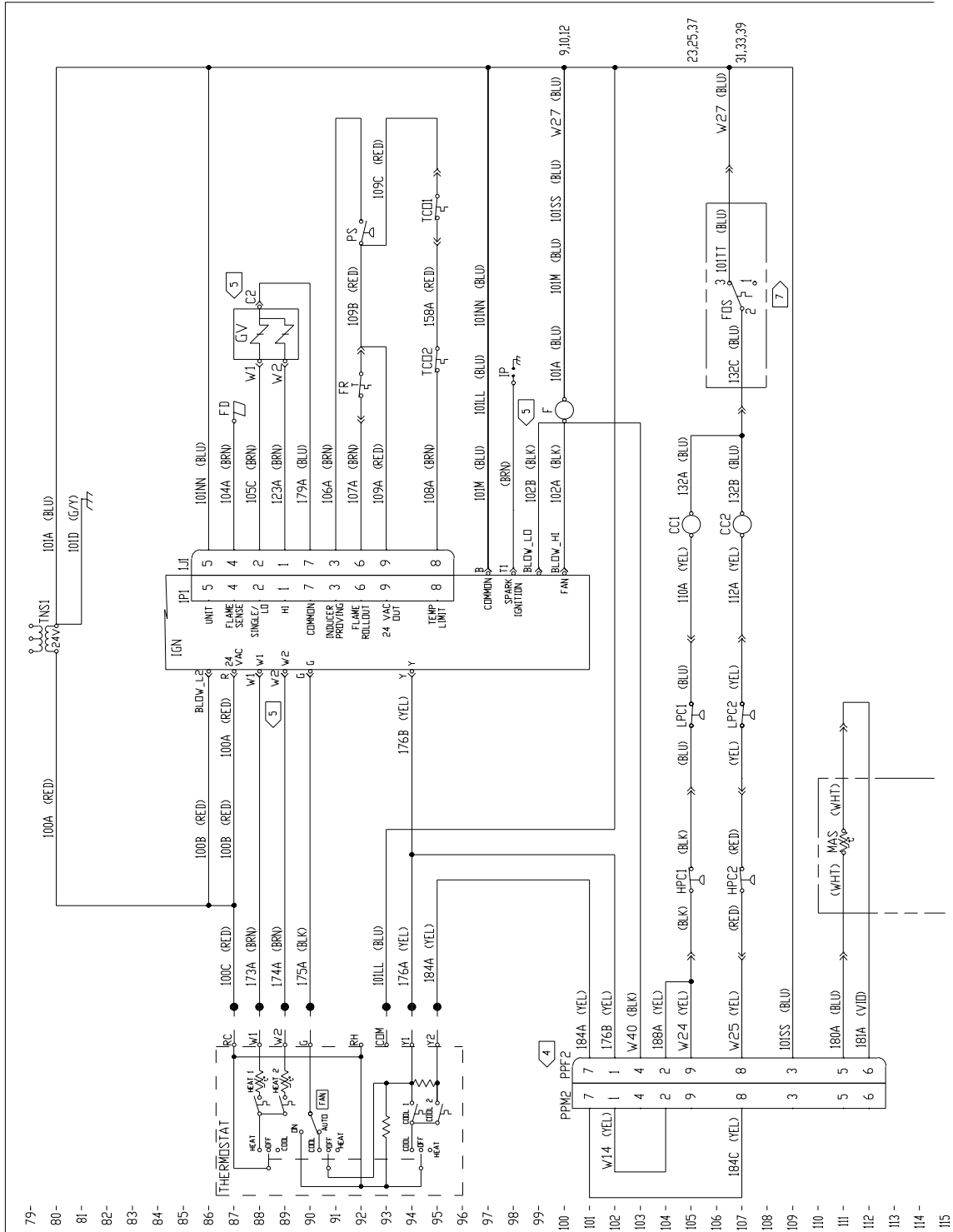
COLOR	ABBR	COLOR	ABBR
BLACK	BLK	ORANGE	ORG
BLUE	BLU	RED	RED
BROWN	BRN	VIOLET (PURPLE)	VID
GRAY (SLATE)	GRA	WHITE	WHT
GREEN/YELLOW	G/Y	YELLOW	YEL

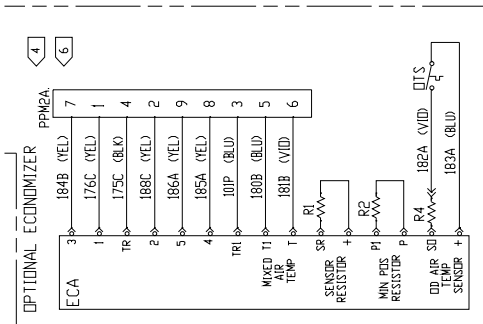
**Diagram 27**  
**Control Schematic -**  
**6 - 7.5 Ton Gas Heat / Single Compressor**  
**4366-1045**





**Diagram 28**  
**Control Schematic -**  
**7.5 - 10 Ton Gas Heat / Dual Compressor**  
**4366-1039**





REF	DESCRIPTION	LINE
CC1	COMPRESSOR CONTACTOR	105
CC2	COMPRESSOR CONTACTOR	107
ECA	ECONOMIZER ACTUATOR	117-131
F	FAN CONTACTOR	100
FD	FLAME DETECTOR	87
FDS	FLAME DETECTOR	107
FR	FLAME ROLLOUT	92
GV	GAS VALVE	88-89
HPC1	HIGH PRESSURE CUTOUT	105
HPC2	HIGH PRESSURE CUTOUT	107
IGN	IGNITION MODULE	86-100
IP	IGNITER	99
LPC1	LOW PRESSURE CUTOUT	105
LPC2	LOW PRESSURE CONTROL	107
MAS	MIXED AIR SENSOR	111
OD	OD AIR TEMP SWITCH	130
PS	PRESSURE SWITCH	92
R1	RESISTOR 750 OHM (RED)	126
R2	RESISTOR 130 OHM (GRN)	128
R4	RESISTOR 620 OHM (WHT)	130
TC01	TEMPERATURE LIMIT SWITCH	95
TC02	TEMPERATURE LIMIT SWITCH	95
TNS1	LOW VOLTAGE TRANSFORMER	80

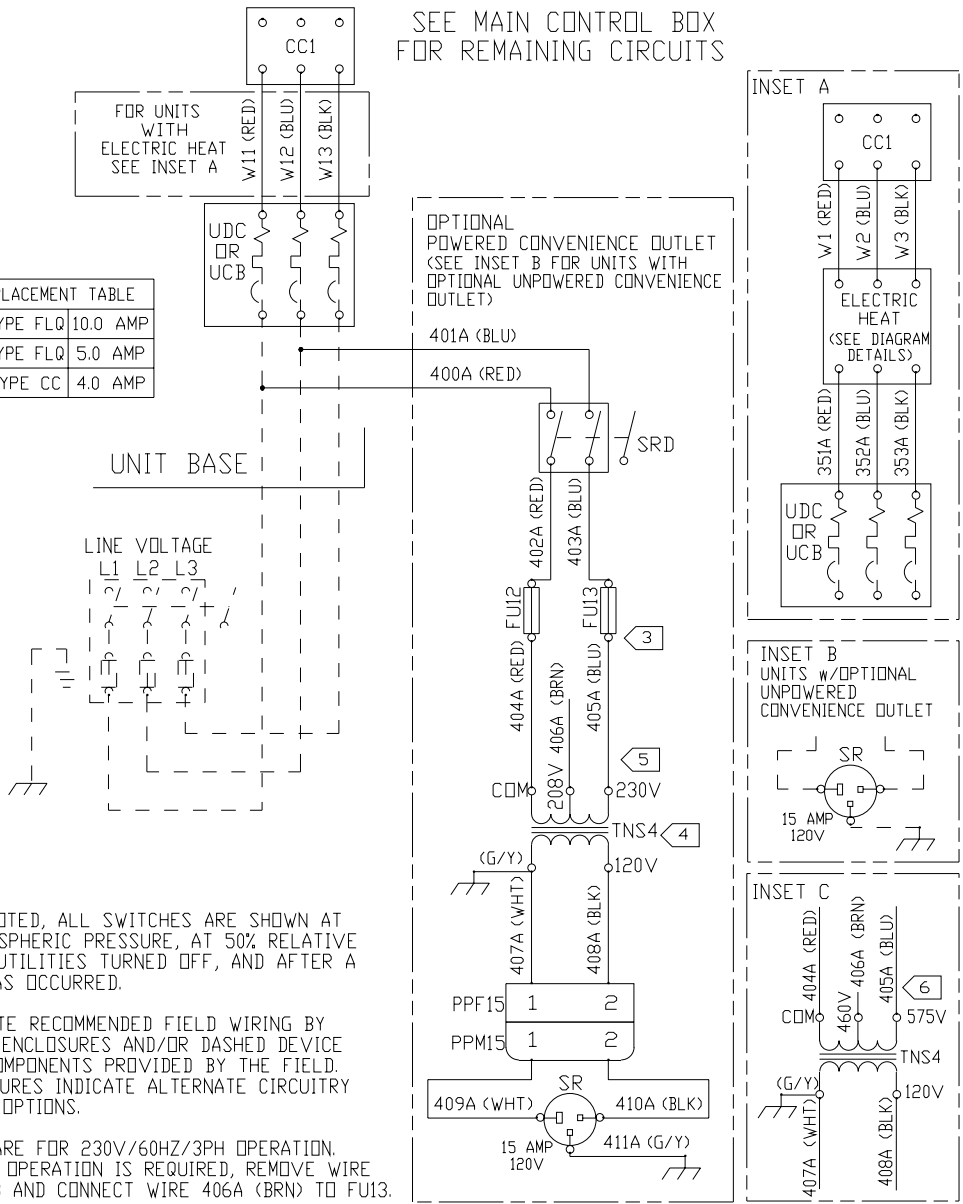
COLOR	ABBR	COLOR	ABBR
BLACK	BLK	ORANGE	ORG
BLUE	BLU	RED	RED
BROWN	BRN	VIOLET (PURPLE)	VIO
GRAY (SLATE)	GRA	WHITE	WHT
GREEN/YELLOW	G/Y	YELLOW	YEL

- UNLESS OTHERWISE NOTED, ALL SWITCHES ARE SHOWN AT 25° C (77° F) AT ATMOSPHERIC PRESSURE. AT 50% RELATIVE HUMIDITY WITH ALL UTILITIES TURNED OFF AND AFTER A NORMAL SHUTDOWN HAS OCCURRED.
- DASHED LINES INDICATE RECOMMENDED FIELD WIRING BY OTHERS. DASHED LINE ENCLOSURES AND/OR DASHED DEVICE OUTLINES INDICATE COMPONENTS PROVIDED BY THE FIELD. PHANTOM LINE ENCLOSURES INDICATE ALTERNATE CIRCUITRY OR AVAILABLE SALES OPTIONS.
- NUMBERS ALONG THE RIGHT SIDE OF THE SCHEMATIC DESIGNATE THE LOCATION OF CONTACTS BY LINE NUMBER. AN UNDERLINED NUMBER INDICATES A NORMALLY CLOSED CONTACT.
- WHEN INSTALLING OPTIONAL ECONOMIZER, REMOVE CONFIG PLUG PPM2, AND CONNECT ECONOMIZER PLUG PPM2A TO PPF2, AND CONNECT WIRE 181A AND 181A.
- CONNECTIONS SHOWN ARE FOR 2-STAGE GAS HEAT OPERATION. WHEN 1-STAGE OPERATION IS REQUIRED, WIRE 102B IS REMOVED, WIRES 101NN AND 174A ARE NOT CONNECTED TO IGN, AND WIRE 123A IS NOT CONNECTED TO GV, AND WIRE 105C IS CONNECTED TO GV-MI.
- FOR MOTORIZED OUTSIDE AIR DAMPER, OPTIONAL MAS AND DTS (AND ASSOCIATED WIRING) ARE NOT USED, AND R4 IS REMOVED BETWEEN S0 AND \*.
- CONNECTIONS SHOWN INCLUDE OPTIONAL FDS. IF FDS IS NOT INSTALLED, CONNECT WIRE 132A TO WIRE W27.

115 -  
116 -  
117 -  
118 -  
119 -  
120 -  
121 -  
122 -  
123 -  
124 -  
125 -  
126 -  
127 -  
128 -  
129 -  
130 -  
131 -  
132 -  
133 -  
134 -  
135 -  
136 -  
137 -  
138 -  
139 -  
140 -  
141 -  
142 -  
143 -  
144 -  
145 -  
146 -  
147 -  
148 -  
149 -  
150 -  
151 -  
152 -  
153 -  
154 -  
155 -  
156 -

**Diagram 29**  
**Through The Base Utilities**  
**4366-1031**

LITTELFUSE: FUSE REPLACEMENT TABLE			
FUI2, FUI3	208V/230V	TYPE FLO	10.0 AMP
FUI2, FUI3	460V	TYPE FLO	5.0 AMP
FUI2, FUI3	575V	TYPE CC	4.0 AMP



NOTES:

- UNLESS OTHERWISE NOTED, ALL SWITCHES ARE SHOWN AT 25°C (77°F), AT ATMOSPHERIC PRESSURE, AT 50% RELATIVE HUMIDITY, WITH ALL UTILITIES TURNED OFF, AND AFTER A NORMAL SHUTDOWN HAS OCCURRED.
- DASHED LINES INDICATE RECOMMENDED FIELD WIRING BY OTHERS. DASHED LINE ENCLOSURES AND/OR DASHED DEVICE OUTLINES INDICATE COMPONENTS PROVIDED BY THE FIELD. PHANTOM LINE ENCLOSURES INDICATE ALTERNATE CIRCUITRY OR AVAILABLE SALES OPTIONS.
- CONNECTIONS SHOWN ARE FOR 230V/60HZ/3PH OPERATION. WHEN 208V/60HZ/3PH OPERATION IS REQUIRED, REMOVE WIRE 405A (BLU) FROM FUI3 AND CONNECT WIRE 406A (BRN) TO FUI3.
- CONNECTIONS SHOWN ARE FOR 230V/60HZ/3PH OPERATION. WHEN 460V/60HZ/3PH OR 575V/60HZ/3PH OPERATION IS REQUIRED, SEE INSET C.
- TAPE WIRE 406A (BRN) TO HARNESS IF UNIT IS WIRED FOR 230V OPERATION. TAPE WIRE 405A (BLU) TO HARNESS IF UNIT IS WIRED FOR 208V OPERATION.
- CONNECTIONS SHOWN ARE FOR 575V/60HZ/3PH UNITS, WITH WIRE 405A (BLU) CONNECTED TO FUI3 AND WIRE 406A (BRN) TAPED TO HARNESS AT TRANSFORMER. FOR 460V/60HZ/3PH APPLICATIONS, CONNECT WIRE 406A (BRN) TO FUI3 AND TAPE WIRE 405A (BLU) TO HARNESS AT TRANSFORMER.

REF	DESCRIPTION
CC1	COMPRESSOR CONTACTOR
FUI2	FUSE
FUI3	FUSE
PPF15	CONV. OUTLET PWR RECEPTACLE
PPM15	CONV. OUTLET PWR PLUG
SR	SERVICE RECEPTACLE - GFCI
SRD	SERVICE RECEPTACLE DISCONNECT
TNS4	SERVICE RECEPTACLE TRANSFORMER
UDC	UNIT DISCONNECT

4366-1031E





---

Literature Order Number	Y_C-SVE001B-EN
File Number	SV-UN-Y_C-SVE001B-EN 11/04
Supersedes	Y_C-SVE001A-EN
Stocking Location	Webb Mason

*The manufacturer has a policy of continuous product and product data improvement and reserves the right to change design and specifications without notice.*