



Gustave A. Larson Company

W232 N2869 Roundy Circle West, Pewaukee, Wi. 53072

13200 10th Ave. North, Suite B, Plymouth, Mn. 55441

CO: Boulder - Colorado Springs - Denver - Ft. Collins - Grand Junction - Pueblo IA: Cedar Rapids - Des Moines - Mason City ID : Idaho Falls IL: Arlington Heights - Broadview - Chicago - Elgin - Rockford - South Holland IN: Evansville - Vincennes MN: Bloomington - Duluth - Plymouth - Rochester - St. Cloud - St. Paul ND: Bismarck - Fargo NE: Grand Island - Lincoln - Omaha (2) SD: Rapid City - Sioux Falls UT: St. George - Salt Lake City WI: Appleton - Eau Claire - Green Bay - LaCrosse - Madison - Milwaukee - New Berlin - Pewaukee - Wausau

262-542-0200

763-546-9508

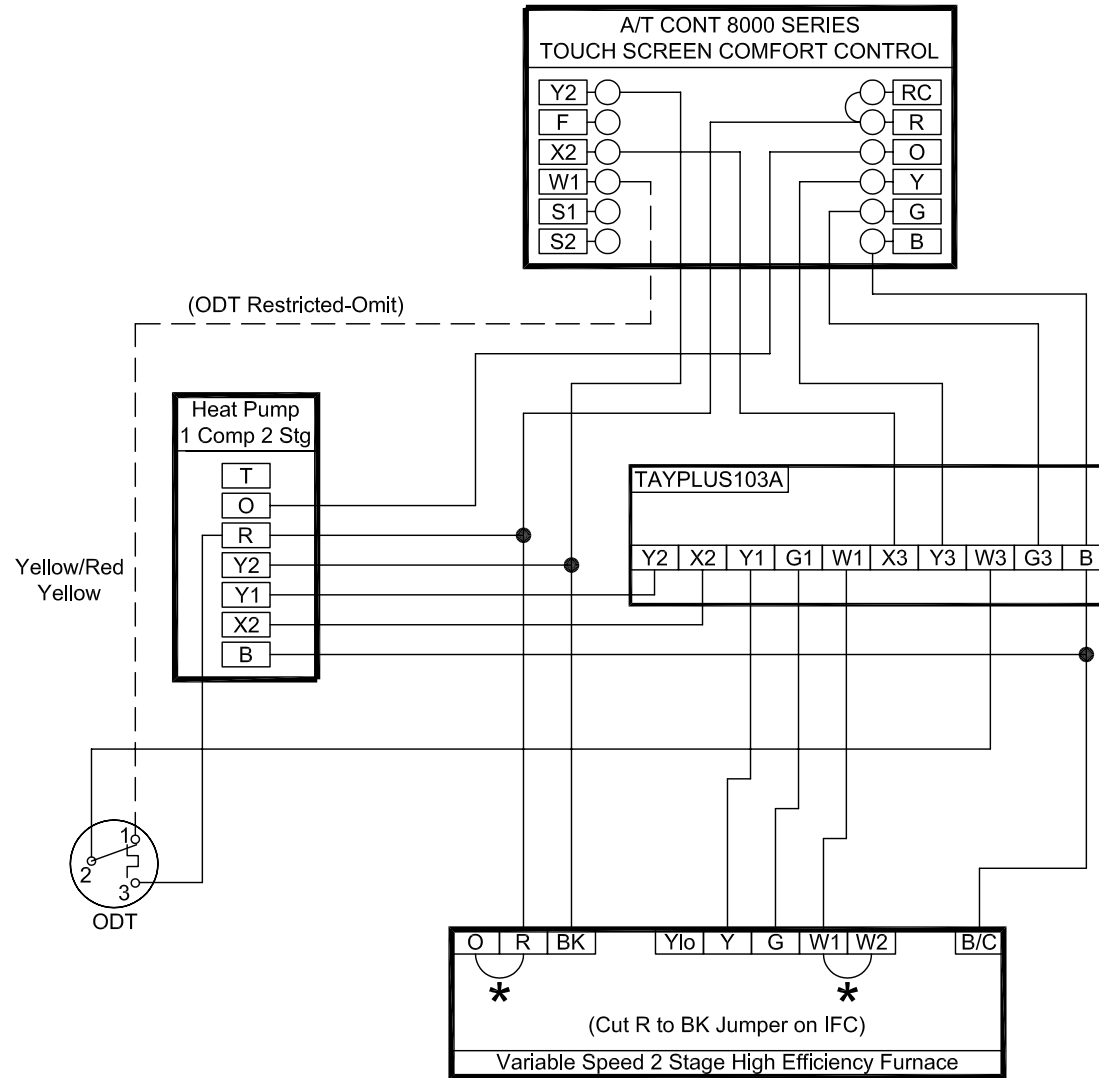

Drawing #:

1C2S HiEff TayP ATCONT Restricted

Notes:

* Field Installed Jumper

Description:

A/T CONT 800 Series Control Circuit
for a One Compressor Two Stage
Heat Pump & Dual Fuel Kit Restricted Mode